

FAN USE

Fully controlled, low-pressure, highly efficient RE radial fans intended for square ducts can be universally used for complex air-conditioning, from simple venting installations to sophisticated air-handling installations. They can be very conveniently used in systems with a large range of output control during operation – important areas of the plant operating at lower than maximum output, when the features of the used EC motors are utilised in the most efficient way. The integrated control electronics also simplify installation and maintenance (there is no need for an external output controller).

Modern impellers feature excellent noise parameters and are suitable for use in duct systems with greater requirements regarding the sound level.

With small fan types equipped with a hinged panel (an impeller), the service panel can be easily loosened and opened by loosening two screws. These fans are ideal, e.g., for kitchen exhaust hoods, where higher levels of grease and the need for periodical cleaning of the impeller can be expected.

Ideally, they can be used along with other components of the Vento modular system, which ensures inter-compatibility and balanced parameters.

OPERATING CONDITIONS, POSITION

These fans are designed for indoor applications. Outdoor applications are possible providing sufficient roofing is ensured. They are designed to transport air without solid, fibrous, sticky, aggressive, respectively explosive impurities. For outdoor applications it is necessary to provide the fans with a protective coating (except for the rating plates).

The transported air must be free of corrosive chemicals or chemicals aggressive to zinc, aluminium or plastics. The permissible operating temperature of the environment and transported air ranges from -25 or -30 °C up to +40 or +60 °C, according to the type. The maximum nominal values for each fan are included in table # 3.

For safe operation of the fan down to the minimum permitted external temperature, it is necessary to provide a continuous electrical power supply, which ensures automatic maintaining of the operating temperature and functionality of the electronic components, even if ventilation (impeller rotation) is not required. The fan must be stopped (except service activities) using a control signal. At the same time, this procedure ensures the long service life of the fan (frequent forced switching decreases the service life).

Warning: As EC motors with permanent magnets are used, it's not possible to operate, store or transport RE fans at ambient temperatures lower than -40 °C!

The fan's EC motors, respectively their integrated electronic components, are as far as their function and design similar in principle to frequency inverters, which are generally used for standard ISO motors (with a brought-out shaft) and are equipped with built-in interference filters for higher harmonic frequencies. Nevertheless, it is necessary to evaluate the area of electromagnetic interference (EMC compatibility) according to the situation at the installation site (it is affected by the final installation and interaction of devices).

RE fans can work in any position, which enables free access to the terminal box and motor.

We recommend adding a 1–1.5 m long piece of straight duct to the fan's outlet to reduce pressure losses in the assembly.

DIMENSIONAL RANGE

RE fans are manufactured in a range of ten sizes according to the A × B dimensions of the connecting flange. The standard dimensional and performance range of single-phase and three-phase RE fans enables designers to optimize all parameters for air flows up to 12,000 m³ per hour. Fans of the dimensional ranges 30-15, 40-20 and 50-25 are manufactured with a hinged impeller, larger types as solid.

MATERIALS

The casing of RE fans, connecting flanges and diffusers are made of galvanized sheet steel (Zn 275 g/m²).

Impeller blades – with backward-curved blades - are made of plastic.

Motors are made of aluminium alloys, copper and plastics.

MOTORS

Electronically switched (so-called EC) compact single-phase and three-phase motors with external rotor are used to drive the fans. The motors are situated inside the impeller, and during operation are optimally cooled by the flowing air.

The motors' high quality enclosed ball bearings with permanent lubricating filling enable the fans to achieve a service life above 40,000 operating hours without maintenance. Motor degree of protection is IP 54.

ELECTRICAL EQUIPMENT

According to the fan type, the wiring can be terminated in a special independent box of IP 54 protection degree for the power connection and in a box of IP 44 protection degree for the control connection or using a two-segment terminal box integrated under the cover directly on the motor body (IP 54).

For wiring diagrams, refer to the separate section "Wiring Diagram". Small types of fans contain a so-called draught output which enables fan operation (rotation) to be monitored. Larger types are equipped with an output non-potential relay contact for failure indication. See Wiring Diagrams.

MOTOR PROTECTION

As standard, permanent automatic monitoring of the internal motor temperature is used in all motors. The electronics of the EC motor control the fan's operation so that it will not be damaged. In case of adverse operating conditions (blocking, repeated overheating, phase failure), the fan is switched off or the failure is signalled (in types equipped with a failure relay). Once the protective functions have been activated, the fans can restart themselves again after subsequent problem removal, cooling, etc. ¹⁾

FAN OUTPUT CONTROL

The output of all RE fans can be fully controlled by changing the speed. The fan's speed is changed by the analogue input using control voltage (0-10 V DC) and the fan (electronics of the motor) provides a constant exciting voltage of 10 V DC for control, or it is possible to control it by an external signal of 0-10 V from a complex control system.

- A potentiometric ORP controller for manual control is available as an accessory.
- It is possible to control two or more fans connected together in parallel to the control signal (max. number - depends on max. possible power supply source load of 10 V) using a power supply of 0-10 V, respectively the potentiometric ORP controller. However, an "exciting" voltage of 10 V must always be used only from one source, respectively a fan (it must never be connected to the 10 V outputs of the remaining fans).
- Simultaneously, the control voltage must be used for operating stoppage of the fan (the power supply must not be disconnected in the standard way) – see "Operating Conditions" above.

TABLE 1

Control voltage [V] DC	Operation state	Fan speed (%)
0-1	STOP	0
>1	OPERATION	see fig. # 1
10	OPERATION	100

FIGURE 1

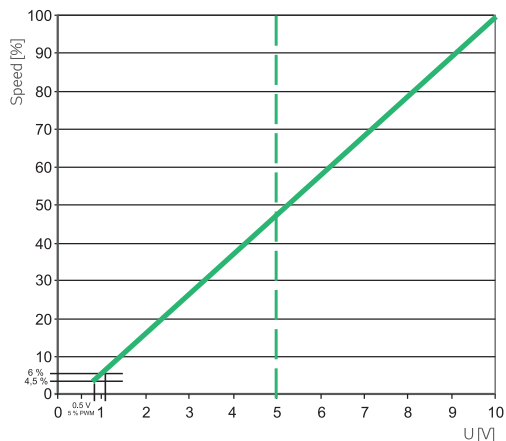

→ For fan speed (flow) control depending on the input signal level, see figure # 1 and table # 1.

The motor will be started with a control signal of 1 V – at approx. 6 % of the rated (maximum) speed. RE fans equipped with EC motors are significantly more effective than voltage-controlled fans equipped with AC motors (RO, RP types, etc.), see figure # 2. Figure # 2 graphically compares the energy consumption of AC and EC fans for nominal output (100 % fan speed) as well as for output control (speed). In comparison with voltage-controlled fans, EC fans can have a lower power input for nominal output (flow) and even lower for the lowered (controlled) output. For example, during operation at 60 % of maximum speed (flow), the input of the highly efficient EC motor is approximately at 20 % of the power input in comparison with 55 % with the AC motor.

¹⁾ Application of this operational behaviour (non-signalled shut-down) must be evaluated within the scope of the air-handling device and control system project.

FIGURE 2 – COMPARISON OF ENERGY DEMANDS FOR VOLTAGE AND EC CONTROL

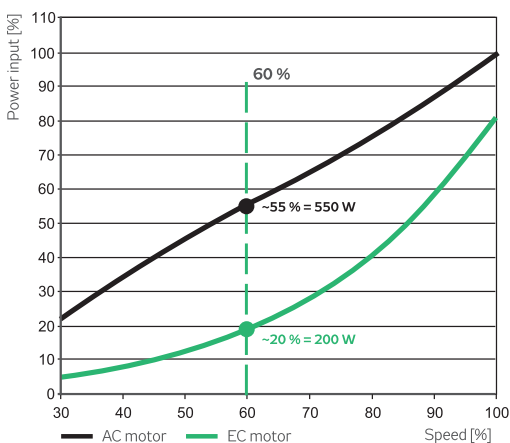

ACCESSORIES

RE fans belong in the wide range of Vento modular venting and air-handling system components. Any air-handling set-up, from simple venting to sophisticated comfortable air-conditioning, can be created by selecting suitable elements. ORP IP 40 or ORP IP 54 controllers are intended for manual start-up and control of the fan output (without using the control unit).

FAN DESCRIPTION AND DESIGNATION

The type designation of RE fans is defined by the key shown in figure # 3. For example, type designation RE 70-40/40-SD specifies the type of fan, impeller and motor. The most frequently used names of the fan's individual parts and structure assemblies are defined in figures # 4 and # 5.

FIGURE 3 – TYPE DESIGNATION OF RP FANS

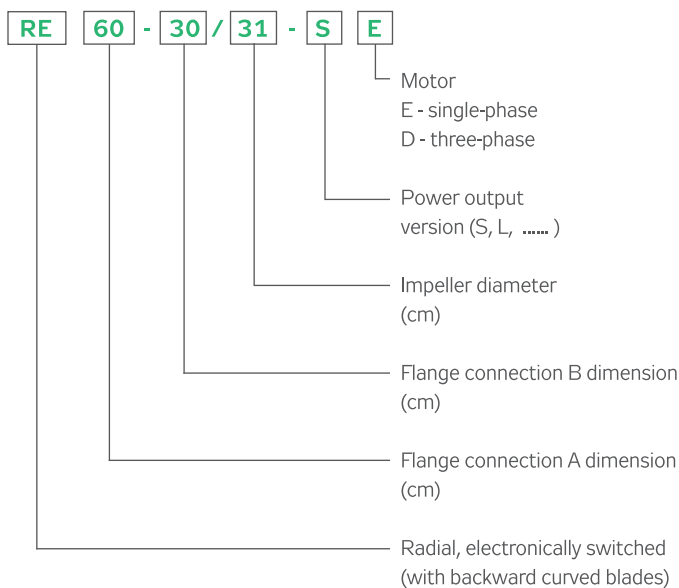
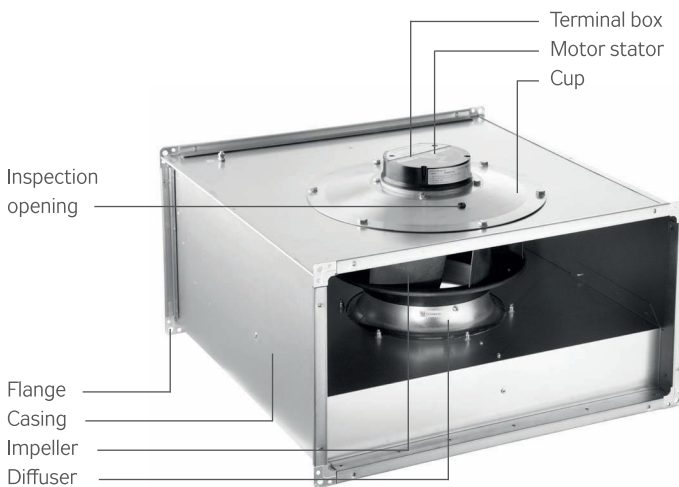

FIGURE 4 – RE FAN DESCRIPTION (SOLID TYPE)



DIMENSIONS, WEIGHTS AND PERFORMANCE

For important dimensions of RE fans, refer to Figure # 5 and Table # 2. For basic parameters and nominal fan values refer to table # 2.

FIGURE 5 – FAN DIMENSIONAL DIAGRAM

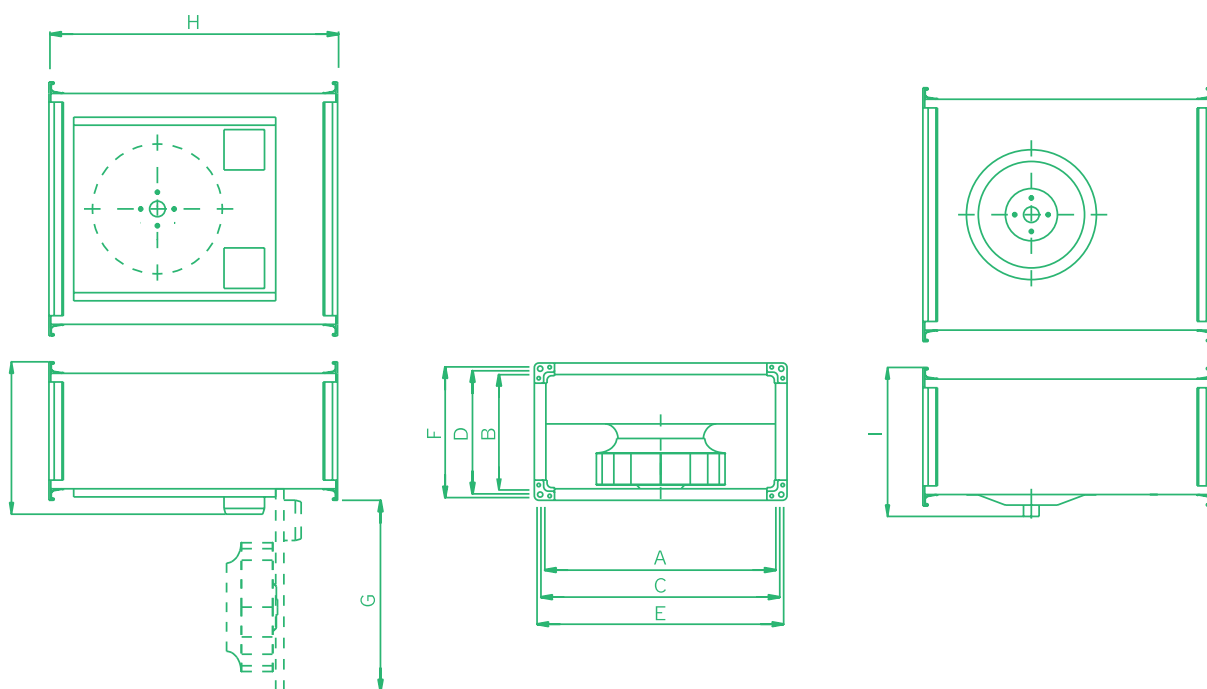

TABLE 2 – FAN DIMENSIONS

Fan type	Dimensions mm								
	A	B	C	D	E	F	G	H	I
RE 30-15/19-SE	300	150	320	170	340	190	258	400	215
RE 40-20/22-SE	400	200	420	220	440	240	280	500	265
RE 50-25/28-SE	500	250	520	270	540	290	395	530	315
RE 50-30/28-SE	500	300	520	320	540	340	-	565	380
RE 60-30/31-SE	600	300	620	320	640	340	-	642	390
RE 60-35/35-SD	600	350	620	370	640	390	-	720	445
RE 60-35/35-SE	600	350	620	370	640	390	-	720	430
RE 70-40/40-SD	700	400	720	420	740	440	-	780	495
RE 70-40/40-SE	700	400	720	420	740	440	-	780	480
RE 80-50/50-SD	800	500	820	520	840	540	-	885	625
RE 80-50/50-LD	800	500	820	520	840	540	-	885	595
RE 90-50/45-SD	900	500	930	530	960	560	-	985	620
RE 90-50/50-SD	900	500	930	530	960	560	-	985	590
RE 100-50/45-SD	1000	500	1030	530	1060	560	-	985	620
RE 100-50/50-SD	1000	500	1030	530	1060	560	-	985	590
RE 100-50/56-SD	1000	500	1030	530	1060	560	-	985	590

TABLE 3 – FAN BASIC PARAMETERS AND NOMINAL VALUES

Fan type	V_{max} m ³ /h	$\Delta p_{t,max}$ Pa	$\Delta p_{t,min}$ Pa	n_{nom} min ⁻¹	U_{nom} V	P_{max} W	I_{max} A	t_{min} °C	t_{max} °C	m kg	ErP2015
SINGLE-PHASE FANS											
RE 30-15/19-SE	709	906	0	3132	230	83	0.75	-25	60	10	✓
RE 40-20/22-SE	1219	800	0	2897	230	170	1.4	-25	60	14	✓
RE 50-25/28-SE	2144	538	0	1842	230	168	1.4	-25	60	18	✓
RE 50-30/28-SE	2531	703	0	2222	230	310	2.1	-25	60	20	✓
RE 60-30/31-SE	2911	591	0	2023	230	370	1.65	-15	60	24	✓
RE 60-35/35-SE	3490	672	0	1482	230	260	1.1	-25	60	29	✓
RE 70-40/40-SE	5314	927	0	1510	230	530	2.3	-25	50	36	✓
THREE-PHASE FANS											
RE 60-35/35-SD	5219	1220	0	2499	400	1270	2.1	-15	60	30	✓
RE 70-40/40-SD	6553	1130	0	2108	400	1450	2.4	-15	60	36	✓
RE 80-50/50-SD	10246	1280	0	1806	400	2600	4.3	-15	60	56	✓
RE 80-50/50-LD	8185	766	0	1397	400	1250	2.1	-15	60	48	✓
RE 90-50/45-SD	10228	1370	0	2122	400	2900	4.8	-20	40	63	✓
RE 90-50/50-SD	9821	1170	0	1335	400	1320	2.1	-25	50	61	✓
RE 100-50/45-SD	10228	1370	0	2122	400	2900	4.8	-20	40	67	✓
RE 100-50/50-SD	9821	1170	0	1335	400	1320	2.1	-25	50	65	✓
RE 100-50/56-SD	12655	864	0	1530	400	2360	3.7	-25	60	73	✓

SYMBOLS USED IN TABLE 3::

- V_{max}** maximum air flow rate
- n** fan speed measured at the highest efficiency working point (5b), rounded to tens
- U** nominal power supply voltage of the motor without control (all values in the table are to this voltage)
- P_{max}** electric motor maximal power output
- I_{max}** maximum phase current at voltage **U** (this value must be checked)
- t_{max}** maximum permissible transported air temperature at air flow **V_{max}** .
- C** capacitor capacity with single-phase fans
- FM.** frequency inverter
- m** weight of the fan (±10%)
- ErP2015** Fan compliance with the requirements of Regulation 2009/125/EC (NOT compliant fans must not be used within EU region)

DATA SECTION

Graph 1 enables quick selection of a suitable fan and alternate comparison of RE fans. Only the highest characteristics of each fan at a control signal of 10 V included are recorded in it, the same way as in diagrams in the specifications of each type.

The Data Section of the catalogue contains all important information and measured data of RE fans.

GRAPH 1 – RE FAN CHARACTERISTICS QUICK SELECTION

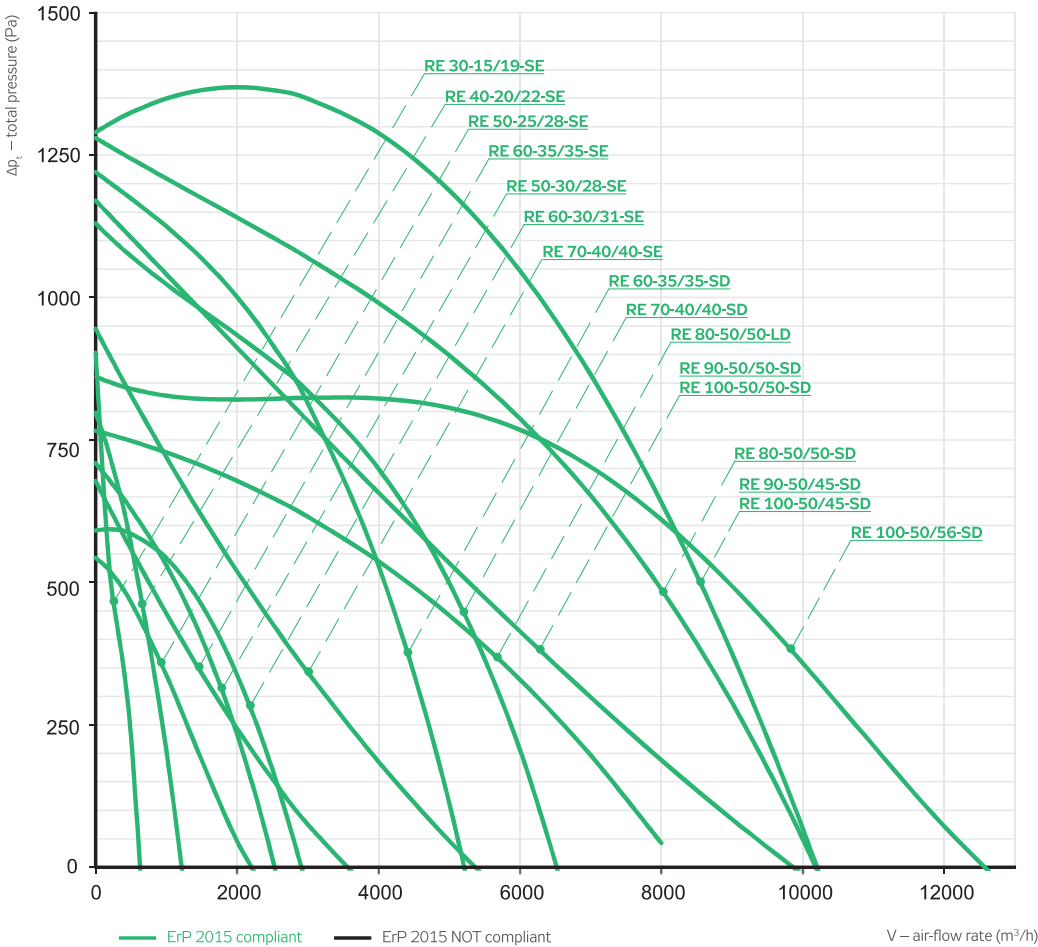

ErP 2015

RE 30-15/19-SE

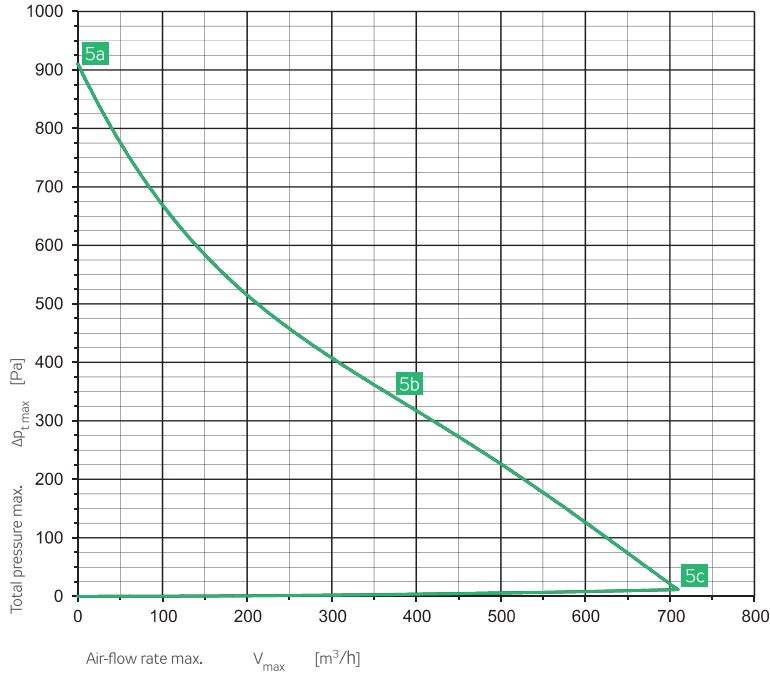

RE 30-15/19-SE

Power supply	230 V	50 Hz
Max. electric input	P_{max} [W]	83
Max. current (5c)	I_{max} [A]	0.75
Mean speed	n [min ⁻¹]	3132
Capacitor	C [μF]	–
Max. working temp.	t_{max} [°C]	60
Max. air-flow rate	V_{max} [m³/h]	709
Max. total pressure	$\Delta p_{t max}$ [Pa]	906
Min. static pressure (5c)	$\Delta p_{s min}$ [Pa]	0
Weight	m [kg]	10
Five-stage controller	type	–
Protecting relay	type	–

	Inlet	Outlet	Surrounding
Point	5b	5b	5b

Total sound power level L_{MAX} [dB(A)]

L_{wMA}	72	75	56
-----------	----	----	----

Sound power level L_{WAKOKT} [dB(A)]

125 Hz	49	53	38
250 Hz	61	64	46
500 Hz	70	73	55
1000 Hz	62	65	43
2000 Hz	64	67	44
4000 Hz	59	62	37
8000 Hz	53	53	31

RE 30-15/19-SE

Parameters in selected working points	5a	5b	5c
Voltage U [V]	230		
Current I [A]	0.7	0.7	0.7
Electric input P [W]	81	84	83
Speed n [min ⁻¹]	4200	3132	3423
Air-flow rate V [m³/h]	0	374	709
Static pressure Δp_s [Pa]	906	334	0
Total pressure Δp_t [Pa]	906	337	12

RE 40-20/22-SE

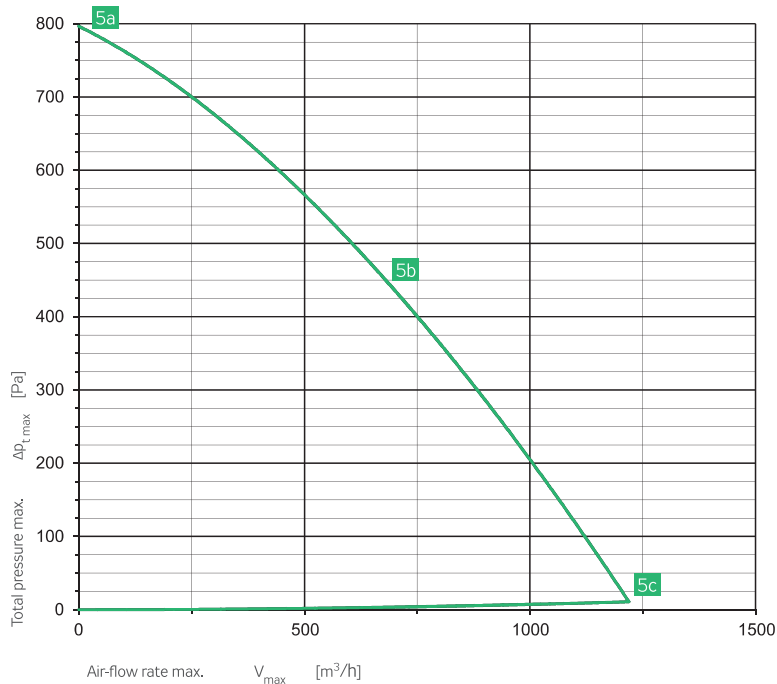

ErP 2015

RE 40-20/22-SE

Power supply	230 V	50 Hz
Max. electric input	P_{max} [W]	170
Max. current (5c)	I_{max} [A]	1.40
Mean speed	n [min ⁻¹]	2897
Capacitor	C [μF]	–
Max. working temp.	t_{max} [°C]	60
Max. air-flow rate	V_{max} [m³/h]	1219
Max. total pressure	$\Delta p_{t,max}$ [Pa]	800
Min. static pressure (5c)	$\Delta p_{s,min}$ [Pa]	0
Weight	m [kg]	14
Five-stage controller	type	–
Protecting relay	type	–

	Inlet	Outlet	Surrounding
Point	5b	5b	5b

Total sound power level L_{MAX} [dB(A)]

L_{WA}	65	76	47
----------	----	----	----

Sound power level L_{WAKOKT} [dB(A)]

125 Hz	46	60	35
250 Hz	57	69	42
500 Hz	56	66	41
1000 Hz	62	71	43
2000 Hz	55	69	35
4000 Hz	51	64	29
8000 Hz	43	56	21

RE 40-20/22-SE

Parameters in selected working points	5a	5b	5c
Voltage U [V]	230		
Current I [A]	0.8	1.4	1.3
Electric input P [W]	94	170	151
Speed n [min ⁻¹]	3270	2897	2996
Air-flow rate V [m³/h]	0	714	1219
Static pressure Δp_s [Pa]	800	428	0
Total pressure Δp_t [Pa]	800	432	11

ErP 2015

RE 50-25/28-SE

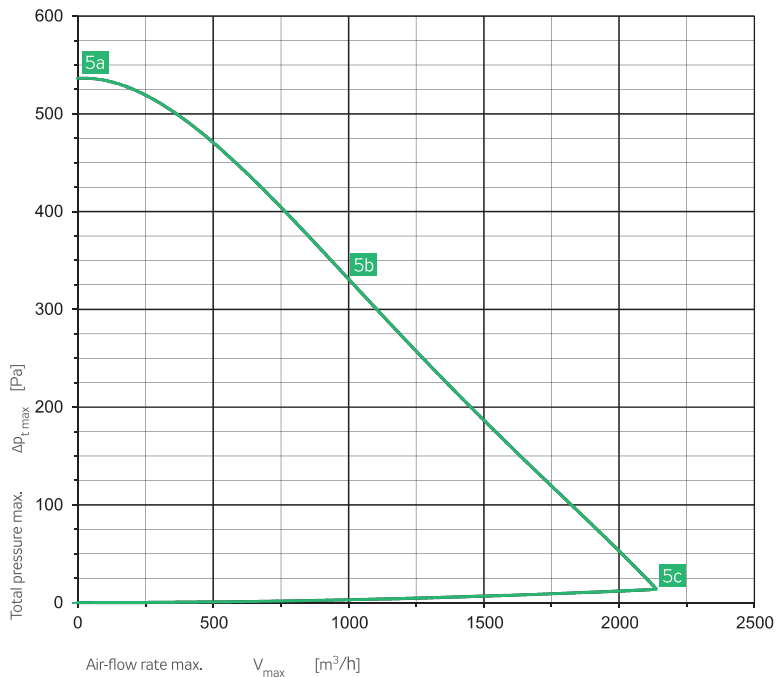

RE 50-25/28-SE

Power supply	230 V	50 Hz
Max. electric input	P_{max} [W]	168
Max. current (5c)	I_{max} [A]	1.40
Mean speed	n [min ⁻¹]	1842
Capacitor	C [μF]	–
Max. working temp.	t_{max} [°C]	60
Max. air-flow rate	V_{max} [m³/h]	2144
Max. total pressure	$\Delta p_{t,max}$ [Pa]	538
Min. static pressure (5c)	$\Delta p_{s,min}$ [Pa]	0
Weight	m [kg]	18
Five-stage controller	type	–
Protecting relay	type	–

	Inlet	Outlet	Surrounding
Point	5b	5b	5b

Total sound power level L_{MAX} [dB(A)]

L_{WA}	70	73	55
----------	----	----	----

Sound power level L_{WAKOKT} [dB(A)]

125 Hz	58	62	47
250 Hz	68	71	53
500 Hz	58	61	43
1000 Hz	62	65	43
2000 Hz	59	62	39
4000 Hz	55	58	33
8000 Hz	46	49	24

RE 50-25/28-SE

Parameters in selected working points	5a	5b	5c
Voltage U [V]	230		
Current I [A]	0.9	1.4	1.3
Electric input P [W]	103	168	162
Speed n [min ⁻¹]	2160	1842	1895
Air-flow rate V [m³/h]	0	1010	2144
Static pressure Δp_s [Pa]	538	334	0
Total pressure Δp_t [Pa]	538	337	14

RE 50-30/28-SE

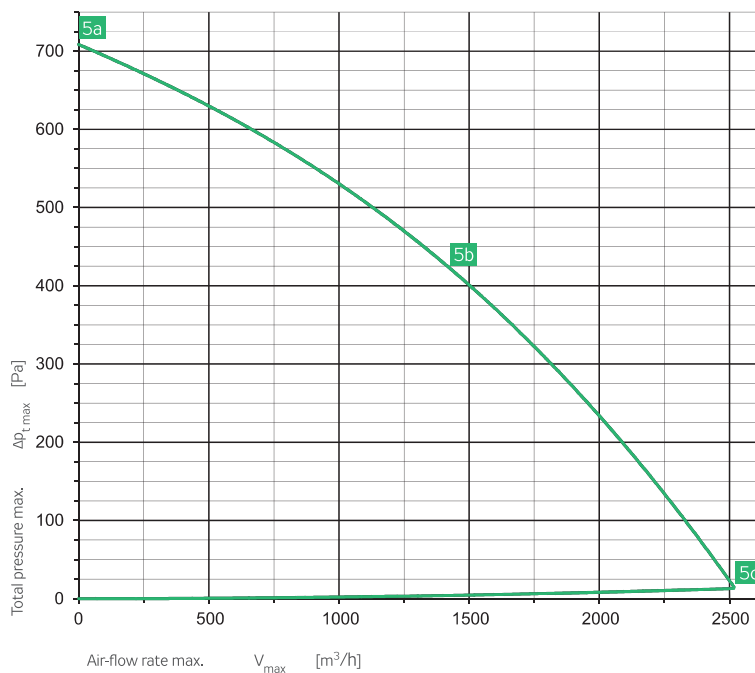

ErP 2015

RE 50-30/28-SE

Power supply	230 V	50 Hz
Max. electric input	P_{max} [W]	310
Max. current (5c)	I_{max} [A]	2.1
Mean speed	n [min ⁻¹]	2222
Capacitor	C [μF]	–
Max. working temp.	t_{max} [°C]	55
Max. air-flow rate	V_{max} [m³/h]	2531
Max. total pressure	$\Delta p_{t,max}$ [Pa]	703
Min. static pressure (5c)	$\Delta p_{s,min}$ [Pa]	0
Weight	m [kg]	20
Five-stage controller	type	–
Protecting relay	type	–

	Inlet	Outlet	Surrounding
Point	5b	5b	5b

Total sound power level L_{MAX} [dB(A)]

L_{WA}	77	81	61
----------	----	----	----

Sound power level L_{WAKOKT} [dB(A)]

125 Hz	61	65	50
250 Hz	75	79	60
500 Hz	62	65	47
1000 Hz	68	72	49
2000 Hz	66	69	46
4000 Hz	62	65	40
8000 Hz	58	61	36

RE 50-30/28-SE

Parameters in selected working points	5a	5b	5c
Voltage U [V]	230		
Current I [A]	0.9	2.0	1.7
Electric input P [W]	128	296	259
Speed n [min ⁻¹]	2400	2222	2255
Air-flow rate V [m³/h]	0	1406	2531
Static pressure Δp_s [Pa]	703	428	0
Total pressure Δp_t [Pa]	703	432	13

RE 60-30/31-SE

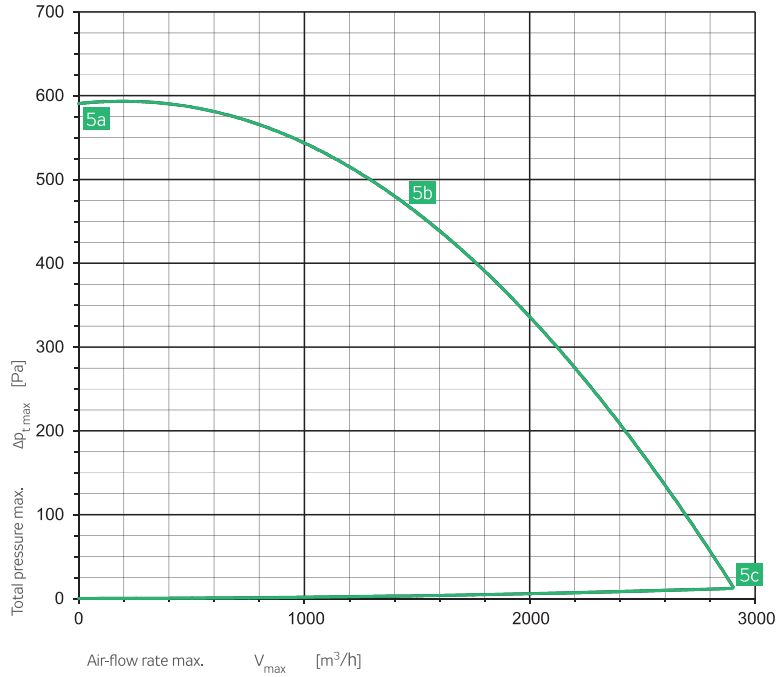

ErP 2015

RE 60-30/31-SE

Power supply	230 V	50 Hz
Max. electric input	P_{max} [W]	370
Max. current (5c)	I_{max} [A]	1.65
Mean speed	n [min ⁻¹]	2023
Capacitor	C [μF]	–
Max. working temp.	t_{max} [°C]	60
Max. air-flow rate	V_{max} [m³/h]	2911
Max. total pressure	$\Delta p_{t,max}$ [Pa]	591
Min. static pressure (5c)	$\Delta p_{s,min}$ [Pa]	0
Weight	m [kg]	24
Five-stage controller	type	–
Protecting relay	type	–

	Inlet	Outlet	Surrounding
Point	5b	5b	5b

Total sound power level L_{MAX} [dB(A)]

L_{WA}	72	76	57
----------	----	----	----

Sound power level L_{WAKOKT} [dB(A)]

125 Hz	62	64	51
250 Hz	69	70	54
500 Hz	64	72	50
1000 Hz	64	69	45
2000 Hz	59	66	39
4000 Hz	55	61	33
8000 Hz	48	54	26

RE 60-30/31-SE

Parameters in selected working points	5a	5b	5c
Voltage U [V]	230		
Current I [A]	0.5	1.6	1.3
Electric input P [W]	115	359	306
Speed n [min ⁻¹]	2020	2023	2026
Air-flow rate V [m³/h]	0	1470	2911
Static pressure Δp_s [Pa]	591	467	0
Total pressure Δp_t [Pa]	591	470	12

RE 60-35/35-SE

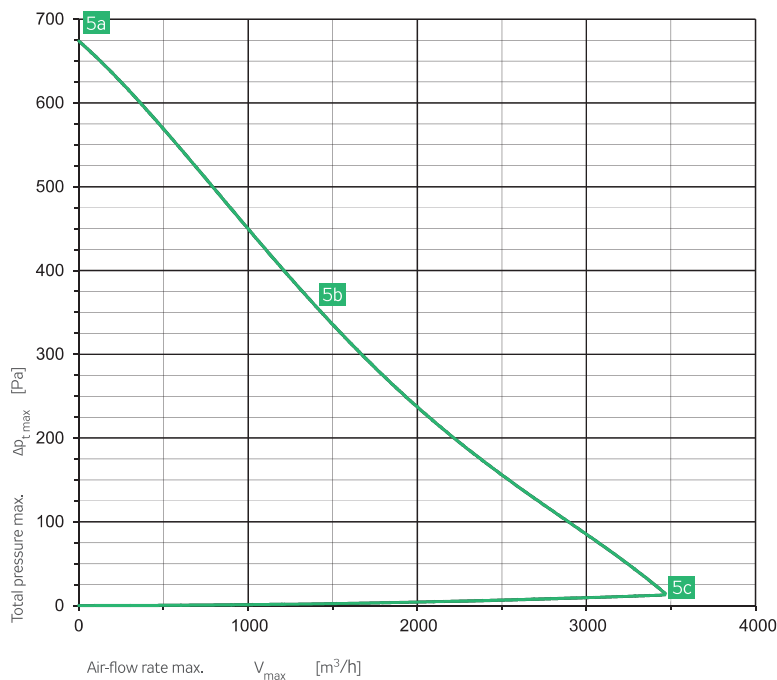

ErP 2015

RE 60-35/35-SE

Power supply	230 V	50 Hz
Max. electric input	P_{max} [W]	260
Max. current (5c)	I_{max} [A]	1.10
Mean speed	n [min ⁻¹]	1482
Capacitor	C [μF]	–
Max. working temp.	t_{max} [°C]	60
Max. air-flow rate	V_{max} [m³/h]	3490
Max. total pressure	$\Delta p_{t,max}$ [Pa]	672
Min. static pressure (5c)	$\Delta p_{s,min}$ [Pa]	0
Weight	m [kg]	29
Five-stage controller	type	–
Protecting relay	type	–

	Inlet	Outlet	Surrounding
Point	5b	5b	5b

Total sound power level L_{MAX} [dB(A)]

L_{WA}	65	70	52
----------	----	----	----

Sound power level L_{WAKOKT} [dB(A)]

125 Hz	61	64	50
250 Hz	58	64	43
500 Hz	57	62	42
1000 Hz	57	61	38
2000 Hz	56	61	36
4000 Hz	49	54	27
8000 Hz	40	44	18

RE 60-35/35-SE

Parameters in selected working points	5a	5b	5c
Voltage U [V]	230		
Current I [A]	0.9	1.1	1.1
Electric input P [W]	210	259	248
Speed n [min ⁻¹]	1880	1482	1570
Air-flow rate V [m³/h]	0	1425	3490
Static pressure Δp_s [Pa]	672	356	0
Total pressure Δp_t [Pa]	672	358	13

RE 60-35/35-SD

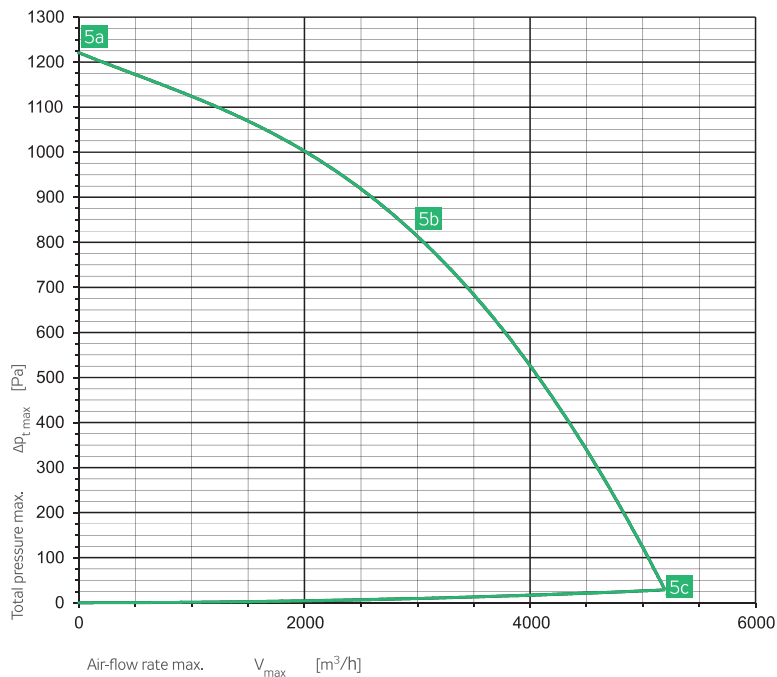

RE 60-35/35-SD

Power supply	Y	3 × 400 V 50 Hz
Max. electric input	P_{max}	[W] 1270
Max. current (5c)	I_{max}	[A] 2.10
Mean speed	n	[min ⁻¹] 2499
Capacitor	C	[μF] –
Max. working temp.	t_{max}	[°C] 60
Max. air-flow rate	V_{max}	[m³/h] 5219
Max. total pressure	$\Delta p_{t max}$	[Pa] 1220
Min. static pressure (5c)	$\Delta p_{s min}$	[Pa] 0
Weight	m	[kg] 30
Five-stage controller	type	–
Protecting relay	type	–

ErP 2015

	Inlet	Outlet	Surrounding
Point	5b	5b	5b

Total sound power level L_{MAX} [dB(A)]

L_{WA}	82	88	67
----------	----	----	----

Sound power level L_{WAKOKT} [dB(A)]

125 Hz	70	71	59
250 Hz	78	81	63
500 Hz	76	81	62
1000 Hz	73	82	54
2000 Hz	73	83	53
4000 Hz	68	75	45
8000 Hz	60	67	38

RE 60-35/35-SD

Parameters in selected working points	5a	5b	5c
Voltage U [V]	400		
Current I [A]	0.8	2.0	1.7
Electric input P [W]	388	1261	1060
Speed n [min ⁻¹]	2500	2499	2499
Air-flow rate V [m³/h]	0	2931	5219
Static pressure Δp_s [Pa]	1220	830	0
Total pressure Δp_t [Pa]	1220	839	29

RE 70-40/40-SE

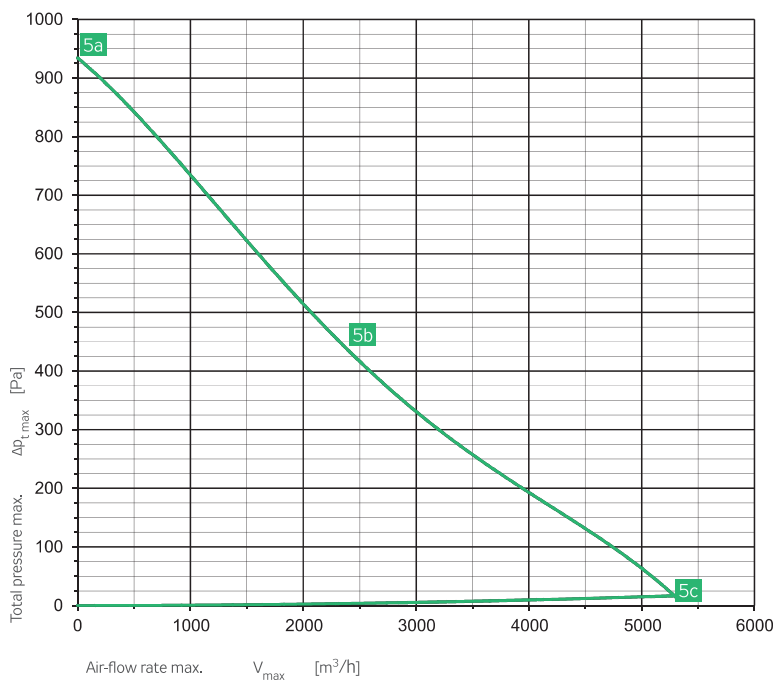

RE 70-40/40-SE

Power supply	230 V	50 Hz
Max. electric input	P_{max} [W]	530
Max. current (5c)	I_{max} [A]	2.30
Mean speed	n [min ⁻¹]	1510
Capacitor	C [μF]	–
Max. working temp.	t_{max} [°C]	50
Max. air-flow rate	V_{max} [m³/h]	5314
Max. total pressure	$\Delta p_{t max}$ [Pa]	927
Min. static pressure (5c)	$\Delta p_{s min}$ [Pa]	0
Weight	m [kg]	36
Five-stage controller	type	–
Protecting relay	type	–

ErP 2015

	Inlet	Outlet	Surrounding
Point	5b	5b	5b

Total sound power level L_{MAX} [dB(A)]

L_{WA}	70	75	56
----------	----	----	----

Sound power level L_{WAKOKT} [dB(A)]

Frequency	64	70	53
125 Hz	64	70	53
250 Hz	63	68	48
500 Hz	63	68	48
1000 Hz	63	68	44
2000 Hz	61	66	41
4000 Hz	56	60	34
8000 Hz	50	55	28

RE 70-40/40-SE

Parameters in selected working points	5a	5b	5c
Voltage U [V]	230		
Current I [A]	1.8	2.3	2.2
Electric input P [W]	412	522	496
Speed n [min ⁻¹]	1970	1510	1661
Air-flow rate V [m³/h]	0	2410	5314
Static pressure Δp_s [Pa]	927	444	0
Total pressure Δp_t [Pa]	927	447	17

RE 70-40/40-SD

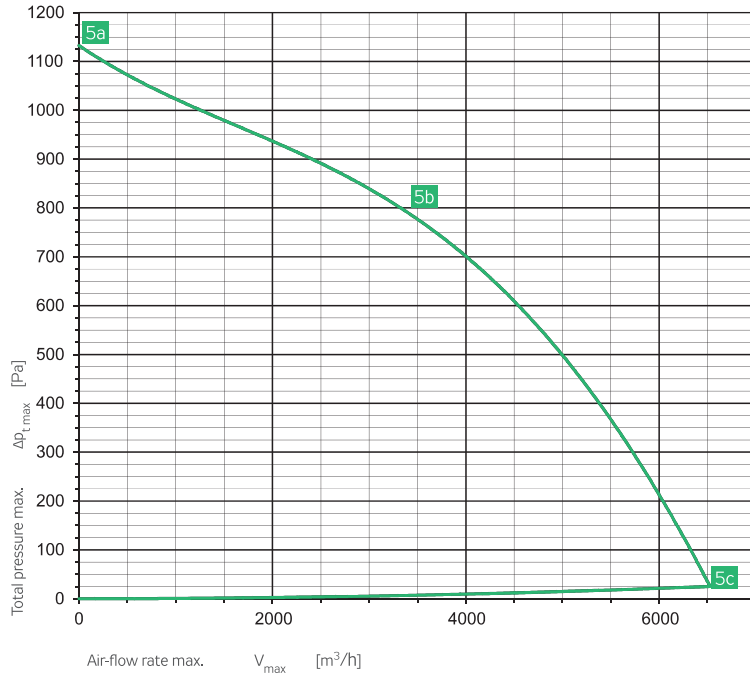

ErP 2015

RE 70-40/40-SD

Power supply	Y	3 × 400 V 50 Hz
Max. electric input	P_{max}	[W] 1450
Max. current (5c)	I_{max}	[A] 2.40
Mean speed	n	[min ⁻¹] 2108
Capacitor	C	[μF] –
Max. working temp.	t_{max}	[°C] 60
Max. air-flow rate	V_{max}	[m³/h] 6553
Max. total pressure	$\Delta p_{t,max}$	[Pa] 1130
Min. static pressure (5c)	$\Delta p_{s,min}$	[Pa] 0
Weight	m	[kg] 36
Five-stage controller	type	–
Protecting relay	type	–

	Inlet	Outlet	Surrounding
Point	5b	5b	5b

Total sound power level L_{MAX} [dB(A)]

L_{WA}	80	87	65
----------	----	----	----

Sound power level L_{WAKOKT} [dB(A)]

125 Hz	71	72	60
250 Hz	74	81	59
500 Hz	76	81	61
1000 Hz	72	81	53
2000 Hz	71	78	52
4000 Hz	67	73	45
8000 Hz	59	66	37

RE 70-40/40-SD

Parameters in selected working points	5a	5b	5c
Voltage U [V]	400		
Current I [A]	0.9	2.2	1.8
Electric input P [W]	444	1422	1173
Speed n [min ⁻¹]	2110	2108	2107
Air-flow rate V [m³/h]	0	3970	6553
Static pressure Δp_s [Pa]	1130	704	0
Total pressure Δp_t [Pa]	1130	714	25

RE 80-50/50-SD

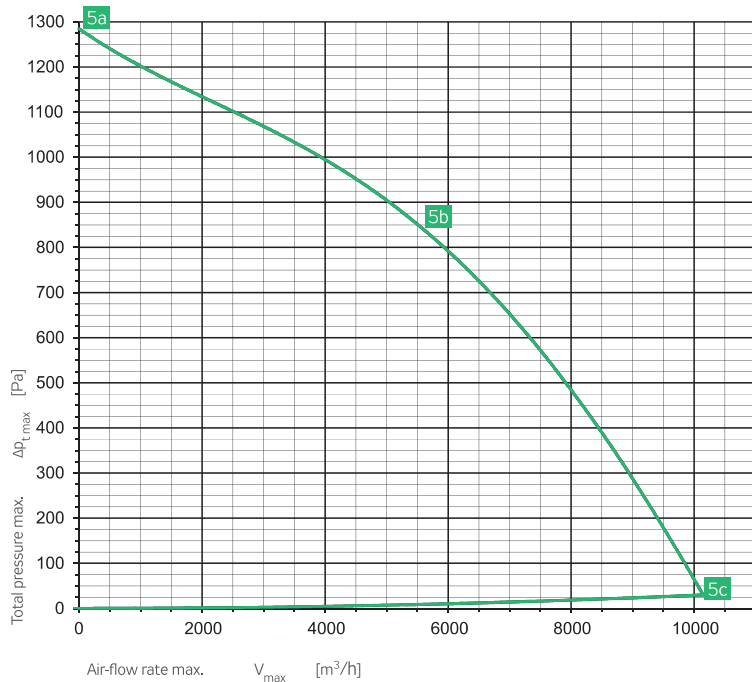

ErP 2015

RE 80-50/50-SD

Power supply	Y	3 × 400 V 50 Hz
Max. electric input	P_{max}	[W] 2600
Max. current (5c)	I_{max}	[A] 4.30
Mean speed	n	[min ⁻¹] 1806
Capacitor	C	[μF] –
Max. working temp.	t_{max}	[°C] 60
Max. air-flow rate	V_{max}	[m³/h] 10246
Max. total pressure	$\Delta p_{t max}$	[Pa] 1280
Min. static pressure (5c)	$\Delta p_{s min}$	[Pa] 0
Weight	m	[kg] 56
Five-stage controller	type	–
Protecting relay	type	–

	Inlet	Outlet	Surrounding
Point	5b	5b	5b

Total sound power level L_{MAX} [dB(A)]

L_{WA}	83	88	68
----------	----	----	----

Sound power level L_{WAKOKT} [dB(A)]

125 Hz	74	75	63
250 Hz	77	82	61
500 Hz	78	83	63
1000 Hz	75	82	56
2000 Hz	73	78	53
4000 Hz	69	74	47
8000 Hz	65	68	43

RE 80-50/50-SD

Parameters in selected working points	5a	5b	5c
Voltage U [V]	400		
Current I [A]	1.7	3.6	3.1
Electric input P [W]	1060	2408	2004
Speed n [min ⁻¹]	1810	1806	1803
Air-flow rate V [m³/h]	0	5595	10246
Static pressure Δp_s [Pa]	1280	835	0
Total pressure Δp_t [Pa]	1280	844	30

RE 80-50/50-LD

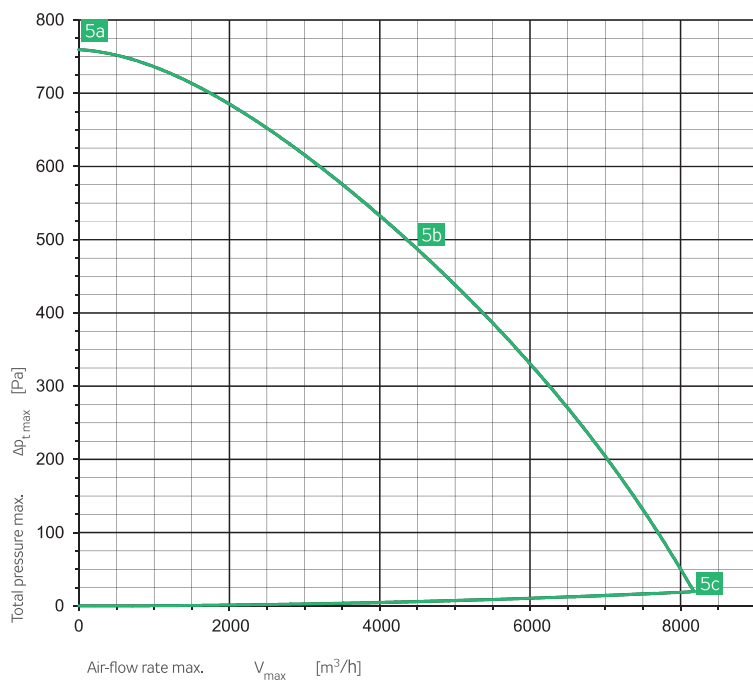

ErP 2015

RE 80-50/50-LD

Power supply	Y	3 × 400 V 50 Hz
Max. electric input	P_{max}	[W] 1250
Max. current (5c)	I_{max}	[A] 2.10
Mean speed	n	[min ⁻¹] 1397
Capacitor	C	[μF] –
Max. working temp.	t_{max}	[°C] 60
Max. air-flow rate	V_{max}	[m³/h] 8185
Max. total pressure	$\Delta p_{t,max}$	[Pa] 766
Min. static pressure (5c)	$\Delta p_{s,min}$	[Pa] 0
Weight	m	[kg] 48
Five-stage controller	type	–
Protecting relay	type	–

	Inlet	Outlet	Surrounding
Point	5b	5b	5b

Total sound power level L_{MAX} [dB(A)]

L_{WA}	77	81	64
----------	----	----	----

Sound power level L_{WAKOKT} [dB(A)]

125 Hz	73	73	62
250 Hz	66	74	51
500 Hz	70	75	55
1000 Hz	67	74	48
2000 Hz	65	70	45
4000 Hz	61	66	39
8000 Hz	56	60	34

RE 80-50/50-LD

Parameters in selected working points	5a	5b	5c
Voltage U [V]	400		
Current I [A]	0.8	1.9	1.6
Electric input P [W]	458	1228	997
Speed n [min ⁻¹]	1400	1397	1395
Air-flow rate V [m³/h]	0	4490	8185
Static pressure Δp_s [Pa]	766	493	0
Total pressure Δp_t [Pa]	766	498	19

RE 90-50/45-SD

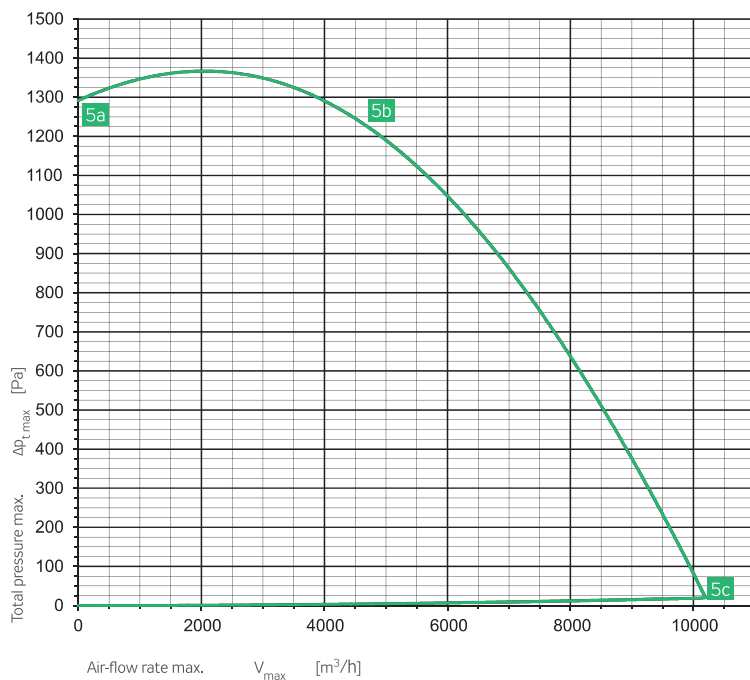

ErP 2015

RE 90-50/45-SD

Power supply	Y	3 × 400 V 50 Hz
Max. electric input	P_{max}	[W] 2900
Max. current (5c)	I_{max}	[A] 4.80
Mean speed	n	[min ⁻¹] 2122
Capacitor	C	[μF] –
Max. working temp.	t_{max}	[°C] 40
Max. air-flow rate	V_{max}	[m³/h] 10228
Max. total pressure	$\Delta p_{t max}$	[Pa] 1370
Min. static pressure (5c)	$\Delta p_{s min}$	[Pa] 0
Weight	m	[kg] 63
Five-stage controller	type	–
Protecting relay	type	–

	Inlet	Outlet	Surrounding
Point	5b	5b	5b

Total sound power level L_{MAX} [dB(A)]

L_{WA}	Inlet	Outlet	Surrounding
	83	90	67

Sound power level L_{WAKOKT} [dB(A)]

Frequency	Inlet	Outlet	Surrounding
125 Hz	73	72	62
250 Hz	74	84	59
500 Hz	77	83	62
1000 Hz	75	86	56
2000 Hz	76	83	56
4000 Hz	71	79	49
8000 Hz	65	71	43

RE 90-50/45-SD

Parameters in selected working points	5a	5b	5c
Voltage U [V]	400		
Current I [A]	1.1	4.3	3.2
Electric input P [W]	688	2795	2059
Speed n [min ⁻¹]	2120	2122	2124
Air-flow rate V [m³/h]	0	4723	10228
Static pressure Δp_s [Pa]	1290	1220	0
Total pressure Δp_t [Pa]	1290	1224	19

ErP 2015

RE 90-50/50-SD

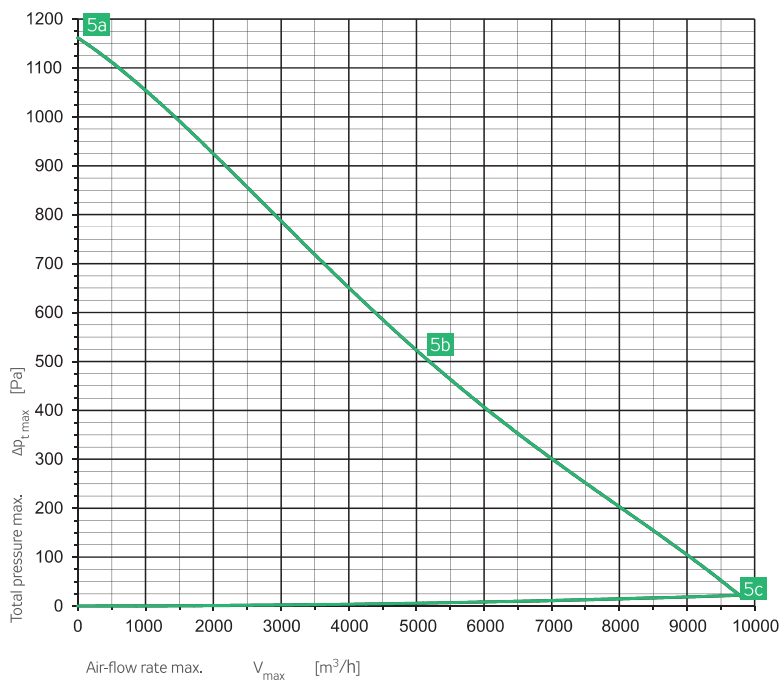

RE 90-50/50-SD

Power supply	Y	3 × 400 V 50 Hz
Max. electric input	P _{max}	[W] 1320
Max. current (5c)	I _{max}	[A] 2.10
Mean speed	n	[min ⁻¹] 1335
Capacitor	C	[μF] –
Max. working temp.	t _{max}	[°C] 50
Max. air-flow rate	V _{max}	[m³/h] 9821
Max. total pressure	Δp _{t max}	[Pa] 1170
Min. static pressure (5c)	Δp _{s min}	[Pa] 0
Weight	m	[kg] 61
Five-stage controller	type	–
Protecting relay	type	–

	Inlet	Outlet	Surrounding
Point	5b	5b	5b

Total sound power level L_{MAX}[dB(A)]

L _{WA}	78	82	63
-----------------	----	----	----

Sound power level L_{WAKOKT} [dB(A)]

125 Hz	71	73	60
250 Hz	67	68	52
500 Hz	71	76	56
1000 Hz	70	79	51
2000 Hz	71	73	51
4000 Hz	67	69	45
8000 Hz	61	63	39

RE 90-50/50-SD

Parameters in selected working points	5a	5b	5c
Voltage U [V]	400		
Current I [A]	1.3	2.0	1.9
Electric input P [W]	830	1284	1236
Speed n [min ⁻¹]	1650	1335	1443
Air-flow rate V [m³/h]	0	5197	9821
Static pressure Δp _s [Pa]	1170	510	0
Total pressure Δp _t [Pa]	1170	516	22

RE 100-50/45-SD

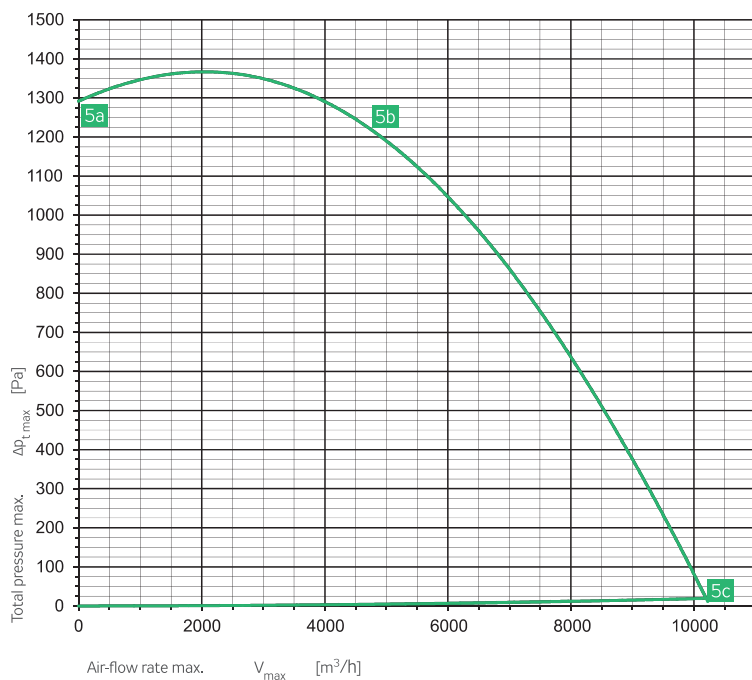

ErP 2015

RE 100-50/45-SD		
Power supply	Y	3 x 400 V 50 Hz
Max. electric input	P_{max}	[W] 2900
Max. current (5c)	I_{max}	[A] 4.80
Mean speed	n	[min ⁻¹] 2122
Capacitor	C	[μF] -
Max. working temp.	t_{max}	[°C] 40
Max. air-flow rate	V_{max}	[m³/h] 10228
Max. total pressure	$\Delta p_{t,max}$	[Pa] 1370
Min. static pressure (5c)	$\Delta p_{s,min}$	[Pa] 0
Weight	m	[kg] 67
Five-stage controller	type	-
Protecting relay	type	-

	Inlet	Outlet	Surrounding
Point	5b	5b	5b

Total sound power level L_{MAX} [dB(A)]

L_{WA}	83	90	67
----------	----	----	----

Sound power level L_{WAKOKT} [dB(A)]

125 Hz	73	72	62
250 Hz	74	84	59
500 Hz	77	83	62
1000 Hz	75	86	56
2000 Hz	76	83	56
4000 Hz	71	79	49
8000 Hz	65	71	43

RE 100-50/45-SD

Parameters in selected working points	5a	5b	5c
Voltage U [V]	400		
Current I [A]	1.1	4.3	3.2
Electric input P [W]	688	2795	2059
Speed n [min ⁻¹]	2120	2122	2124
Air-flow rate V [m³/h]	0	4723	10228
Static pressure Δp_s [Pa]	1290	1220	0
Total pressure Δp_t [Pa]	1290	1224	19

RE 100-50/50-SD

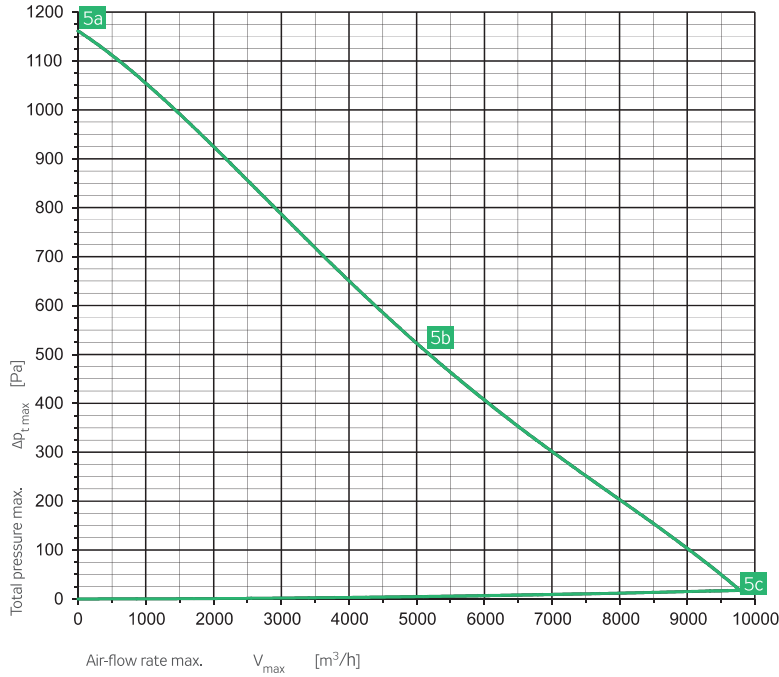

ErP 2015

RE 100-50/50-SD

Power supply	Y	3 × 400 V 50 Hz
Max. electric input	P_{max}	[W] 1320
Max. current (5c)	I_{max}	[A] 2.10
Mean speed	n	[min ⁻¹] 1335
Capacitor	C	[μF] –
Max. working temp.	t_{max}	[°C] 50
Max. air-flow rate	V_{max}	[m³/h] 9821
Max. total pressure	$\Delta p_{t max}$	[Pa] 1170
Min. static pressure (5c)	$\Delta p_{s min}$	[Pa] 0
Weight	m	[kg] 65
Five-stage controller	type	–
Protecting relay	type	–

	Inlet	Outlet	Surrounding
Point	5b	5b	5b

Total sound power level L_{MAX} [dB(A)]

L_{WA}	78	82	63
----------	----	----	----

Sound power level L_{WAKOKT} [dB(A)]

125 Hz	71	73	60
250 Hz	67	68	52
500 Hz	71	76	56
1000 Hz	70	79	51
2000 Hz	71	73	51
4000 Hz	67	69	45
8000 Hz	61	63	39

RE 100-50/50-SD

Parameters in selected working points	5a	5b	5c
Voltage U [V]	400		
Current I [A]	1.3	2.0	1.9
Electric input P [W]	830	1284	1236
Speed n [min ⁻¹]	1650	1335	1443
Air-flow rate V [m³/h]	0	5197	9821
Static pressure Δp_s [Pa]	1170	510	0
Total pressure Δp_t [Pa]	1170	515	18

RE 100-50/56-SD

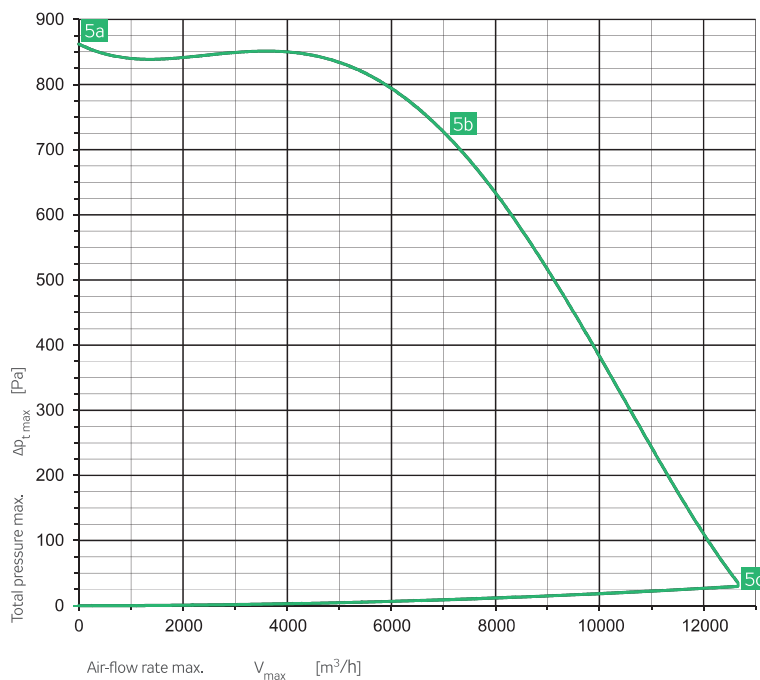

ErP 2015

RE 100-50/56-SD

Power supply	Y	3 x 400 V 50 Hz
Max. electric input	P_{max}	[W] 2360
Max. current (5c)	I_{max}	[A] 3,70
Mean speed	n	[min ⁻¹] 1530
Capacitor	C	[μF] -
Max. working temp.	t_{max}	[°C] 60
Max. air-flow rate	V_{max}	[m³/h] 12655
Max. total pressure	$\Delta p_{t max}$	[Pa] 864
Min. static pressure (5c)	$\Delta p_{s min}$	[Pa] 0
Weight	m	[kg] 73
Five-stage controller	type	-
Protecting relay	type	-

	Inlet	Outlet	Surrounding
Point	5b	5b	5b

Total sound power level L_{MAX} [dB(A)]

L_{WA}	84	89	69
----------	----	----	----

Sound power level L_{WAKOKT} [dB(A)]

125 Hz	75	75	64
250 Hz	75	75	60
500 Hz	79	83	64
1000 Hz	76	85	57
2000 Hz	75	81	55
4000 Hz	72	76	50
8000 Hz	66	66	44

RE 100-50/56-SD

Parameters in selected working points	5a	5b	5c
Voltage U [V]	400		
Current I [A]	1.8	3.7	3.1
Electric input P [W]	1050	2348	1960
Speed n [min ⁻¹]	1540	1530	1537
Air-flow rate V [m³/h]	0	7078	12654
Static pressure Δp_s [Pa]	864	697	0
Total pressure Δp_t [Pa]	864	706	30

INSTALLATION

- RE fans (including other Vento system elements and equipment) are not intended, due to their concept, for direct sale to end customers. Each installation must be performed in accordance with a professional project created by a qualified air-handling designer who is responsible for proper selection of the fan. Installation and commissioning may only be performed by an authorized company licensed in accordance with generally valid regulations.
- It is recommended to insert DV elastic connections in front of and behind the fan.
- It is advisable to always place KFD or VFK air filters, respectively a VFT grease filter, in front of the fan to protect the fan and duct against pollution and dust fouling.
- In cramped spaces, it is advisable to consider the necessity to situate directly behind the fan's outlet the duct adapting piece, attenuator, heat exchanger, heater, etc. Figure # 4 shows the fan's outlet design and arrangement.

- It is obvious that from the entire cross-section (e.g. 500 x 250) only 1/2 of the outlet cross-section is free. This means that the airflow velocities close behind the fan can be as much as two times higher than, for example, in the inlet. Therefore, the greater the distance of the attenuators (or other resistant elements) from the outlet, the better. On the inlet side a DV elastic connection will be sufficient as a distance piece in most cases.
- RE fans can work in any position. When positioned under the ceiling, it is advisable to situate the fan (especially those with a hinged panel) with its motor and terminal box directed downwards to make access to the motor and terminal box easy.

WIRING

- The wiring can be performed only by a qualified worker licensed in accordance with national regulations.
- The fans enable the power supply and control to be connected using cables with conductors of 1.5mm² cross-section in both types of terminal boxes (see Wiring).

FIGURE 6 – WIRING ACCORDING TO TYPES

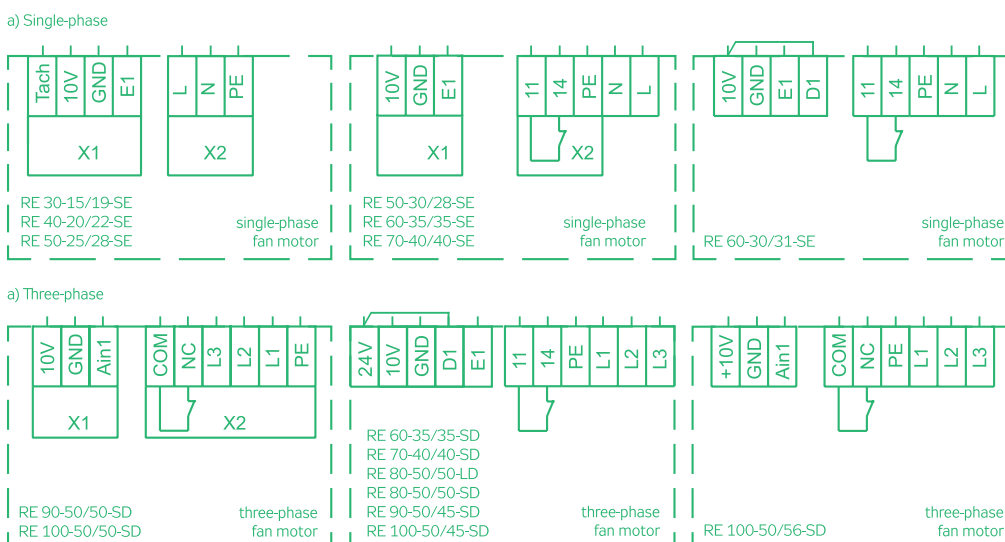

Terminals description (summary):

- L1, L2, L3** – power supply
- N** – neutral conductor
- PE** – protective conductor
- 11, 14** – Summary fan failure (loading of the 250 V AC, 2 A contact)
- NC, COM** – Summary fan failure (loading of the 250 V AC, 2 A contact)

- D1** – digital input (on/off)
- E1** – input 0–10 V DC
- Ain1** – input 0–10 V DC
- 10V** – voltage source 10 V DC
- 24V** – voltage source 24 V DC
- GND** – ground

EXAMPLES, RE FANS

Fans
RP

Fans
RO

Fans
RO

Fans
RE

Fans
RF

Fans
RPH

Fans
EX

Controllers
...

EXAMPLE A
WIRING WITH MANUAL POTENTIOMETRIC
CONTROLLER (ORP)

An RE fan connection in a venting system with output control using the ORP controller is shown in figure # 8. This connection ensures:

- Start-up and step-less control of the RE fan's output using the ORP controller.
- The RE fan motor is protected by the integrated control electronics.
- Service switch-off is enabled by the switch situated in the power supply.

EXAMPLE B
WIRING OF TWO RE FANS
AND CONTROL UNIT

This method of wiring enables start-up and control of the fan output in 5 degrees to be used via the control unit's functions – in manual operation mode or time program.

- The RE fan does not require an external output controller (it contains an integrated one).
- The control unit provides operation control and failure assessment.

FIGURE 7 – FAN CONNECTION

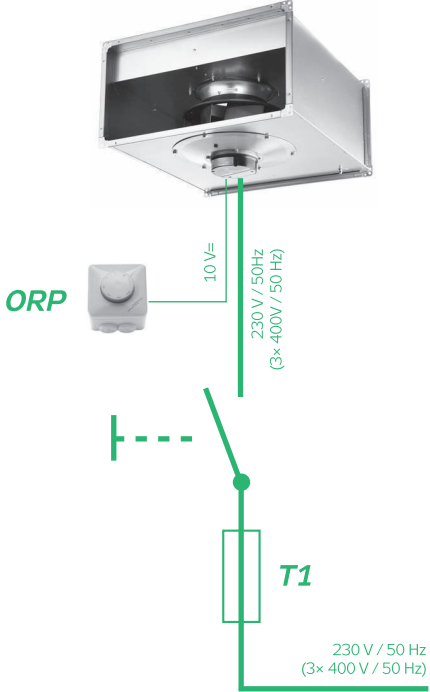
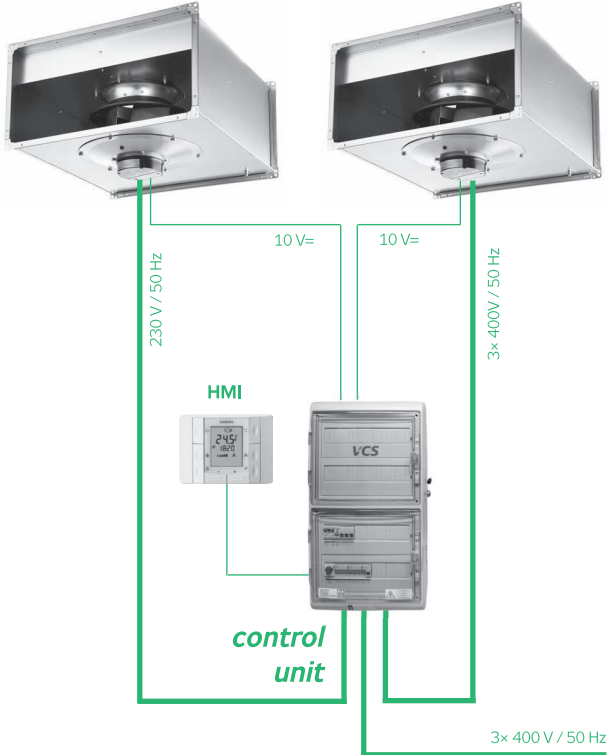

FIGURE 8 – FAN CONNECTION



- Fans RP
- Fans RO
- Fans RO
- Fans RE
- Fans RF
- Fans RPH
- Fans EX
- Controllers ...