

UNIcon

CPG-..AV

Sensor-control module for differential pressure and volume

Operating Instructions



Software version: D1673A from Version 1.03

Content

1	General notes	4
1.1	Structure of the operating instructions	4
1.2	Target group	4
1.3	Exclusion of liability	4
1.4	Copyright	4
2	Safety instructions	5
3	Product overview	6
3.1	Operational area	6
3.2	Functional description	6
3.3	Storage	7
3.4	Waste disposal / recycling	7
4	Mounting	7
4.1	General notes	7
4.2	Temperature influences during commissioning	8
5	Electrical installation	8
5.1	Safety precautions	8
5.2	EMC-compatible installation of control lines	9
5.3	Connection Voltage supply	9
5.4	Output voltage 0 - 10 V	9
5.5	Input for switch over Setpoint 1 / Setpoint 2	9
6	Device construction	10
7	Menu operation	11
7.1	Select operation mode	11
7.2	Menu structure	12
7.3	Menus of Modes 4.00 - 5.01	13

8	Start-up	15
8.1	Procedure	15
8.2	Measuring ranges and tolerance of pressure sensor ..	16
9	Programming	17
9.1	Pressure sensor 4.00 / pressure controller 4.01	17
9.1.1	Basic setting 4.00 and 4.01	17
9.1.2	Settings for operation modes only 4.01	17
9.2	Air volume sensor 5.00 / air volume controller 5.01 ..	18
9.2.1	Basic setting 5.00 and 5.01	18
9.2.2	Settings for operation modes only 5.01	19
10	Check sensor function	20
11	Enclosure	21
11.1	Technical data	21
11.2	Connection diagram	22
11.3	Dimensions [mm]	22
11.4	Manufacturer reference	23
11.5	Service information	23

1 General notes

1.1 Structure of the operating instructions

Before installation and start-up, read this manual carefully to ensure correct use!

We emphasize that these operating instructions apply to specific units only, and are in no way valid for the complete system!

Use these operating instructions to work safely with and on the device. They contain safety instructions that must be complied with as well as information that is required for failure-free operation of the device.

Keep these operating instructions together with the device. It must be ensured that all persons that are to work on the device can refer to the operating instructions at any time.

1.2 Target group

The operating instructions address persons entrusted with planning, installation, commissioning and maintenance and servicing and who have the corresponding qualifications and skills for their job.

1.3 Exclusion of liability

To allow for future developments, construction methods and technical data given are subject to alteration. We do not accept any liability for possible errors or omissions in the information contained in data, illustrations or drawings provided.

We accept no liability for damage caused by misuse, incorrect use, improper use or as a consequence of unauthorized repairs or modifications.

1.4 Copyright

These operating instructions contain copyright protected information. The operating instructions may be neither completely nor partially photocopied, reproduced, translated or put on data medium without previous explicit consent. Infringements are liable for

damages. All rights reserved, including those that arise through patent issue or registration on a utility model.

2 Safety instructions

- Mounting, electrical connection, and start-up operation may only be carried out by an electrical specialist in accordance with electrotechnical regulations (e.g. DIN EN 50110 or DIN EN 60204)!
- Persons entrusted with the planning, installation, commissioning and maintenance and servicing in connection with the device must have the corresponding qualifications and skills for these jobs. In addition, they must be knowledgeable about the safety regulations, EU directives, rules for the prevention of accidents and the corresponding national as well as regional and in-house regulations.
- The equipment is to be used solely for the purposes specified and confirmed in the order. Other uses which do not coincide with, or which exceed those specified will be deemed unauthorised unless contractually agreed. Damages resulting from such unauthorised uses will not be the liability of the manufacturer. The user will assume sole liability.
- It is strictly forbidden for work to be carried out on any components while they are connected to live voltage.
- The safe isolation from the supply must be checked using a two-pole voltage detector.
- The owner is obliged to ensure that the device are operated in perfect working order only.
- Inspect electrical equipment periodically: retighten loose connections – immediately replace damaged lines and cables.
- Never clean electrical equipment with water or similar liquids.
- A separate fault and performance monitoring-system with an alarm signal function is necessary in order to prevent personal injuries and material damages during malfunctions and in case the device fails. Substitute operation must be taken into consideration!

3 Product overview

3.1 Operational area

Pressure and volume control for ventilation systems.

3.2 Functional description

Sensor with a membrane system suitable for measuring differential or negative pressure of non-aggressive gas.

The differential pressure to be measured takes effect on a spring supported silicone membrane.

Function when the pressure at the “Plus”- connection exceeds the pressure at the “Minus”- connection.

Changes in position of the membrane are detected by a differential transformer and converted into an output signal of 0 - 10 V by an electronics unit.

The pressure range from 50 Pa to 6000 Pa is covered with 3 types of device. With each type four calibrated measuring ranges are programmable.

Depending on the programmed Mode the device can be used as sensor or as a control module for pressure or volume.

- For operation as pressure sensor the device supplies an output signal (0 - 10 V) proportional to the measuring range.
- For operation as air volume sensor the device supplies an output signal (0 - 10 V) proportional to the air volume measuring range (👉 INFO / Range qV). Function in combination with centrifugal fans and ring conduit in the inlet duct. The controller calculates the air volume of the fan from the “K-Factor” and pressure differential between the suction side and the inlet duct.
- For operation as control module for pressure or volume the purpose of the device is to reach and maintain the target value set. To accomplish this, the measured actual value (sensor value) is compared with the adjusted target value, and the controlled value is deduced from this. Controlled out-

put (0 - 10 V) e.g. for activating a speed controller for fans or an EC-fan directly.

3.3 Storage

- The device must be stored in its original packaging in a dry and weather-proof room.
- Avoid exposure to extreme heat and cold.
- Avoid over-long storage periods (we recommend a maximum of one year).

3.4 Waste disposal / recycling

Disposal must be carried out professionally and environmentally friendly in accordance with the legal stipulations.

4 Mounting

4.1 General notes



Attention!

The following points must be complied with during the mechanical installation to avoid causing a defect in the device due to assembly errors or environmental influences:

- Before installation remove the device from the packing and check for any possible shipping damage!
- Assemble the device on a clean and stable base. Do not distort during assembly! Use the appropriate mounting devices for proper installation of the unit!
- When mounted onto lightweight walls, there must be no impermissibly high vibrations or shock loads. Any banging shut of doors that are integrated into these lightweight walls, can result in extremely high shock loads. Therefore, we advise you to decouple the devices from the wall.
- Do not allow drilling chips, screws and other foreign bodies to reach the device interior!

- **The pressure measuring depends on position, therefore the mounting must be made vertical and as possible on a vibration-free place (cable inlet and pressure connections down).**
- The pressure line's connection should be with plastic-hose (in building), inside diameter 4 / 5 mm.

4.2 Temperature influences during commissioning

Avoid condensation in the controller and functional faults attributable to condensation by storing the controller at room temperature!

5 Electrical installation

5.1 Safety precautions



Danger owing to electric current

- **Work on electric components may only be carried out by trained electricians or by persons instructed in electricity under the supervision of an electrician in accordance with electrical engineering regulations.**
- **The programming of the equipment takes place with switched on supply voltage by opened cover and voltage for change-over Setpoint 1/2. Use power supplies which guarantee reliable electrical isolation of the operating voltage as per IEC/DIN EN 60204-1. Consider also the general requirements for PELV circuits in accordance with IEC/DIN EN 60204-1.**
- Inspect electrical equipment periodically: retighten loose connections – immediately replace damaged lines and cables.
- Never clean electrical equipment with water or similar liquids.



Information

The respective connections are represented in the enclosure of this manual (☞ Connection diagram)!

5.2 EMC-compatible installation of control lines

Pay attention to maintain sufficient distance from powerlines and motor wires to prevent interferences. The control cable may not be longer than 30 m. Screened control cables must be used when the cable length is longer than 20 m!

5.3 Connection Voltage supply

Connection Voltage supply at terminals: “+Ub” and “GND”. Here, it must be strictly observed that the mains voltage lies within the allowable tolerance specifications (☞ Technical data and name-plate affixed to the side).

5.4 Output voltage 0 - 10 V

Connection to terminals “A” - “GND” (I_{\max} 0.3 mA).

It is not permissible to connect outputs of several devices to each other!

5.5 Input for switch over Setpoint 1 / Setpoint 2

Via voltage at terminals “1” and “2” (10... 24 V DC) a switchover between Setpoint 1 and Setpoint 2 is possible (note polarity☞ connection diagram).

100 Pa
Setpoint 1

None Voltage at terminals “1” and “2” = adjustment for Setpoint1 active.

80 Pa **C**
Setpoint 2

Voltage at terminals “1” and “2” = adjustment for Setpoint 2 active.

The active Setpoint is indicated in the menu INFO, an active “Setpoint 2” is signaled by the moon symbol.

6 Device construction

Screw off the hinged cover to proceed with electrical connection and programming. Subsequently close carefully!

	D	LC-Display Moon symbol = Adjustment for Setpoint 2 active ! = Exceeding measuring range
	+Ub / GND	Supply voltage
	A / GND	Output signal 0 - 10 V
	1 / 2	Voltage input for switch over Setpoint 1 / Setpoint 2
		Pressure connections
	+	“Plus”- connection in area with higher pressure
	-	“Minus”- connection in area with lower pressure

Multipurpose LC display and internal keyboard

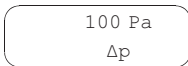

Text line 1 with 16 figures for display of actual and desired values

Text line 2 with 16 figures for display of menu text

P ▼ ▲

- P** Program key and open menu
- ▼** Menu selection, reduce value
- ▲** Menu selection, increase value
- ▼ + ▲** ESC-key combination, Escape = leave menu

7 Menu operation

7.1 Select operation mode

i

Information

Simple installation is possible through the selection of the preprogrammed mode of operation.

This determines the basic function of the device, factory set **4.01**.

Mode	Function
4.00	Pressure sensor output 0...10 V proportional to measuring range
4.01	Pressure controller (PID): output 0...10 V depending on adjusted Setpoint and measured actual value.
5.00	Air volume sensor: Output 0...10 V proportional to measuring range (depending on setting for K-Factor)
5.01	Air volume controller (PID): Output 0...10 V depending on adjusted Setpoint and measured actual value

7.2 Menu structure

100 Pa Δp	Display after turning on the voltage supply. Switch over between actual value display and “INFO” with the key shortcut for Escape (ESC = ▼ + ▲).	INFO
--------------	--	------

Example for Mode **4.01** (Factory setting)

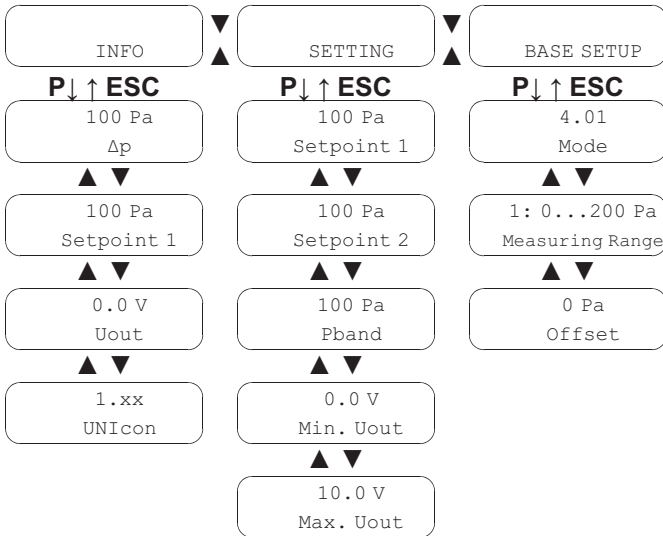

Selection of the menu group (e.g. BASE SETUP) to the right through the ▼-key, to the left through the ▲-key. You can go to the menu items in the menu groups (e.g. mode) by using the P key. Use the arrow keys to move up and down within the menu group. To make adjustments, press the P key after selecting the menu item. If the previously set value starts to flash, it can be adjusted with the ▼ + ▲ keys and then saved with the P key. To exit the

menu without making any changes, use the “ESC” short-key, i.e., the originally set values remain.

Reprogramming Mode 4.01 to 5.00 in “BASE SETUP”

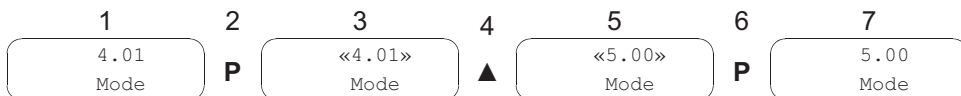

7.3 Menus of Modes 4.00 - 5.01

Parameter	Factory setting				User Setting	?
INFO						
Δp	100 Pa	0 Pa	-	-		Display actual value for differential pressure
qV	-	-	530 m ³ /h	0 m ³ /h		Display actual value for airflow
Setpoint 1	-	100 Pa	-	530 m ³ /h		Display active Setpoint
Range qV	-	-	1060 m ³ /h	1060 m ³ /h		Air volume measuring range depending on sensor measuring range and K-Factor
Uout	5.0 V	10.0 V	5.0 V	10.0 V		Magnitude of the output voltage 0...10 V
UNIcon	1.00	1.00	1.00	1.00		software version
Δp	-	-	49 Pa	0 Pa		Display actual value for volume measurement
						only for 4.01 and 5.01
SETTING						
Setpoint 1	-	100 Pa	-	500 m ³ /h		Setting Setpoint
Setpoint 2	-	100 Pa	-	500 m ³ /h		Setpoint 2 active, if voltage at terminals 1, 2

Parameter	Factory setting				User Setting	?
Pband	-	100 Pa	-	500 m ³ /h		Setting Pband
Min. Uout	-	0.0 V	-	0.0 V		Setting minimal output voltage
Max. Uout	-	10.0 V	-	10.0 V		Setting maximal output voltage
BASE SETUP						
Mode	4.00	4.01	5.00	5.01		Mode selection
Measuring Range	1: 0...200 Pa 2: 0...150 Pa 3: 0...100 Pa 4: 0...50 Pa					Setting Measuring range Type CPG-200AV Factory setting = max. Range
Measuring Range	1: 0...1000 Pa 2: 0...500 Pa 3: 0...300 Pa 4: 0...200 Pa					Setting Measuring range Type CPG-1000AV Factory setting = max. Range
Measuring Range	1: 0...6000 Pa 2: 0...4000 Pa 3: 0...3000 Pa 4: 0...2000 Pa					Setting Measuring range Type CPG-6000AV Factory setting = max. Range
K-Factor	-	-	75	75		K-Factor of inlet duct
Offset	0 Pa	0 Pa	0 m ³ /h	0 m ³ /h		Sensor offset

- Parameter for selected mode not available

8 Start-up

8.1 Procedure

1. You must mount and connect the device in accordance with the operating instructions.
2. Double check that all connections are correct.
3. The supply voltage must match the information on the rating plate.
4. Set the operating Mode in the **BASE SETUP** (factory settings **4.01**).
5. When saving the Operating Mode, the factory settings are stored.
Therefore the settings you have made, e.g. in “SETTING” are lost.



Attention, electrostatic sensitive devices!

Be sure to ground the board at a suitable point in order to prevent damage to the electronic components being caused by electrostatic discharges. Such damage could occur, e.g., if a metal water pipe or heating line are briefly touched.

8.2 Measuring ranges and tolerance of pressure sensor

At the factory the devices are set to the respective highest measuring range (= MB1). As small as possible measuring range must be chosen for maximum accuracy at maximum resolution of the output signal (☞ BASE SETUP of respective Mode).

Measuring ranges and tolerance (4.00 output 0 - 10 V)					
Type	NA	EA	LA	A	H
MB [Pa]	[%]	[%]	[%]	[%]	[%]
CPG-200AV					
MB1: 0...200	+/-0.5	+/-0.5	+/-0.25	0.1	1.0
MB2: 0...150	+/-0.75	+/-0.6	+/-0.4	0.2	0.7
MB3: 0...100	+/-1.0	+/-0.7	+/-0.5	0.2	0.5
MB4: 0...50	+/-2.0	+/-1.0	+/-1.0	0.3	0.5
CPG-1000AV					
MB1: 0...1000	+/-0.5	+/-0.5	+/-0.25	0.1	0.2
MB2: 0...500	+/-0.7	+/-0.7	+/-0.5	0.2	0.2
MB3: 0...300	+/-0.9	+/-0.9	+/-0.9	0.3	0.2
MB4: 0...200	+/-1.0	+/-1.0	+/-1.25	0.3	0.2
CPG-6000AV					
MB1: 0...6000	+/-0.5	+/-0.5	+/-0.25	0.1	0.2
MB2: 0...4000	+/-0.7	+/-0.7	+/-0.4	0.15	0.2
MB3: 0...3000	+/-0.9	+/-0.9	+/-0.6	0.2	0.2
MB4: 0...2000	+/-1.0	+/-1.0	+/-0.75	0.25	0.2
Temperature drift (related to the highest measuring range) Zero point: +/-0.2 % / 10 K, final value: +/- 0.2 % / 10 K					
MB = Measuring range, NA = Zero point deviation, EA = Final value deviation, LA = Linearity deviation, A = Resolution, H = Hysteresis					

9 Programming

9.1 Pressure sensor **4.00** / pressure controller **4.01**

9.1.1 Basic setting **4.00** and **4.01**

BASE SETUP	BASE SETUP
4.01 Mode	Mode Mode selection e.g. 4.01
0...200 Pa Measuring Range	Measuring Range Setting of desired pressure measuring range Setting range: depending on device type (☞ Technical data) Factory setting: respective max. measuring range
0 Pa Offset	Offset Sensor calibration with calibrated comparison device Setting range: -100...+100 Pa Factory setting: 0 Pa

9.1.2 Settings for operation modes only **4.01**

SETTING	SETTING
100 Pa Setpoint 1	Setpoint 1 Setting range: Setpoint 1: 0...100 % sensor measuring range Factory setting: 50 % sensor measuring range
100 Pa Setpoint 2	Setpoint 2 Setting "Setpoint 2" e.g. reduced value for night operation. Switching setpoint 1/2 via external voltage at terminals 1/2.
100 Pa Pband	Pband Narrow control range = Short control times Wide control range = Longer control times and more stable control Setting range Pband: 0...100% sensor measuring range Factory setting: 50 % sensor measuring range

0.0 V Min. Uout	<p>Min. Uout Setting range minimal output voltage (basic speed): 0.0 V...10.0 V (setting takes priority over “Max. Uout”) Factory setting: 0.0 V</p>
10.0 V Max. Uout	<p>Max. Uout Setting range maximal output voltage (speed limiter): 10.0 V...0.0 V Factory setting: 10.0 V</p>

9.2 Air volume sensor **5.00** / air volume controller **5.01**

9.2.1 Basic setting **5.00** and **5.01**

BASE SETUP	BASE SETUP
5.01 Mode	<p>Mode Mode selection 5.01</p>
0...200 Pa Measuring Range	<p>Measuring Range Setting of desired pressure measuring range Setting range: depending on device type (☞ Technical data) Factory setting: respective max. measuring range</p>
75 K-Factor	<p>K-Factor Input of the “K factor” dependent on the fan (inlet duct). Setting range: depending on measuring range of sensor Factory setting: 75</p>
0 m ³ /h Offset	<p>Offset Sensor calibration with calibrated comparison device. Setting range: -32000...+32000 m³/h Factory setting: 0 m³/h</p>

Air volume measuring range [m³/h] depends on selected measuring range of pressure sensor [Pa] and selected “K-Factor”. In menu “INFO” display for “Range qV”. In the case of input of the maximally in each case possible K-Factor theoretically a maximum measuring range of approx. 65000³/h results.

The maximal adjustable K-Factor depends on the selected measuring range of the pressure sensor [Pa].

Measuring Range [Pa]	50	100	150	200	300	500	1000	2000	3000	4000	6000
Max. K-Factor	5000	5000	5000	4596	3752	2906	2055	1453	1186	1027	839

9.2.2 Settings for operation modes only **5.01**

SETTING	SETTING
530 m3/h Setpoint 1	Setpoint 1 Setting range Setpoint 1: 0...Max. Range qV Factory setting: 50 % Max. Range qV
530 m3/h Setpoint 2	Setpoint 2 Setting "Setpoint 2" e.g. reduced value for night operation. Switching setpoint 1/2 via external voltage at terminals 1/2.
530 m3/h Pband	Pband Narrow control range = Short control times Wide control range = Longer control times and more stable control Adjustable Pband: 0...Max. Range qV Factory setting: 50 % Max. Range qV
0.0 V Min. Uout	Min. Uout Setting range minimal output voltage (basic speed): 0.0 V...10.0 V (setting takes priority over "Max. Uout") Factory setting: 0.0 V
10.0 V Max. Uout	Max. Uout Setting range maximal output voltage (speed limiter): 10.0 V...0.0 V Factory setting: 10.0 V

10 Check sensor function

1. Program Mode **4.00** for pressure sensor.
2. Voltage supply (+Ub and GND) connected, output 0 - 10 V (A - GND) disconnected.
3. Remove pressure hoses and measure output signal, nominal = 0 V.
4. Create pressure at the "+" connection against the "-" connection (e.g. by **carefully** blowing in), measure the output signal (0...10 V $\hat{=}$ measuring range).
5. If the sensor works, reconnect the pressure hoses and check these if necessary.

11 Enclosure

11.1 Technical data

Type	CPG-200AV	CPG-1000AV	CPG-6000AV
Part.-No.	320042	320043	320044
Pressure measuring range 1	0...200 Pa	0...1000 Pa	0...6000 Pa
Pressure measuring range 2	0...150 Pa	0...500 Pa	0...4000 Pa
Pressure measuring range 3	0...100 Pa	0...300 Pa	0...3000 Pa
Pressure measuring range 4	0...50 Pa	0...200 Pa	0...2000 Pa
Air flow-Measuring range	max. 65000 m ³ /h (depending on set measuring range and K factor)		
Voltage supply	10 V...24 V DC Protected against reverse polarity		
Current consumption	6 mA		
Output (0 - 10 V)	I _{max} 0.3 mA (short-circuit-proof)		
Pressure connections	"+, -": tubing d = 5 / 6 mm		
Housing	Cover ABS, bottom Polyamid PA 6.6 Fire protection classification UL 94 HB		
Use position	vertical (measuring depends on position)		
Protection class	IP 54 according EN 60529		
Weight	approx. 250 g		
Permissible ambient temperature	-10...50 °C		
Permissible rel. humidity	85 % no condensation		
Overload protection	0,2 bar		
Static pressure max.	0,2 bar		
Interference emission	according EN 61000-6-3 (domestic household applications)		
Interference immunity	according 61000-6-2 (industrial applications)		

11.2 Connection diagram

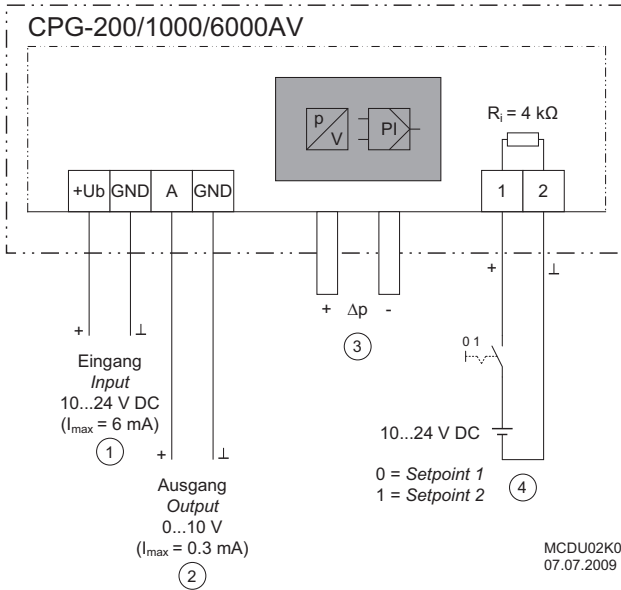

- 1 input 10...24 V DC (I_{max} 6 mA)
- 2 Output 0...10 V (I_{max} = 0,3 mA)
- 3 Pressure connections
- 4 Voltage input for switch over Setpoint 1 / Setpoint 2

11.3 Dimensions [mm]

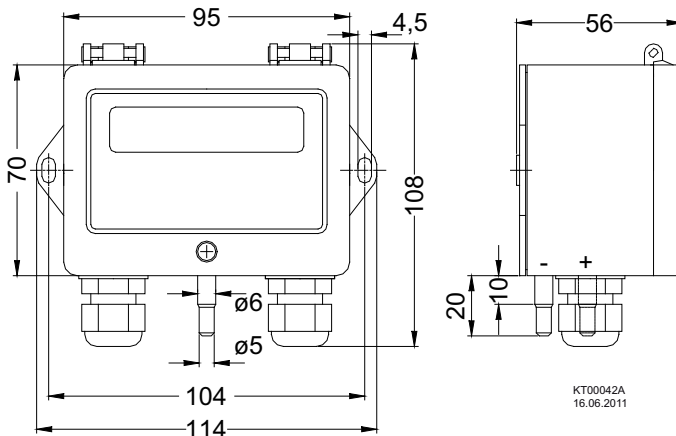

11.4 Manufacturer reference

Our products are manufactured in accordance with the relevant international regulations. If you have any questions concerning the use of our products or plan special uses, please contact:

Ziehl-Abegg AG
Heinz-Ziehl-Straße
74653 Künzelsau
Telephone: +49 (0) 7940 16-0
Telefax: +49 (0) 7940 16-504
info@ziehl-abegg.de
http://www.ziehl-abegg.de

11.5 Service information

If you have any technical questions while commissioning or regarding malfunctions, please contact our V-STE support department for control systems - ventilation technology.

Our worldwide contacts are available in our subsidiaries for deliveries outside of Germany.  www.ziehl-abegg.com.

If you make returns for inspections or repairs we need certain information in order to facilitate focused trouble shooting and fast repair. Please use our repair tickets for this. It is provided to you after you have consulted our support department.

In addition, you can download it from our homepage. Download - Ventilation Technology - Topic: Control Engineering - Document type: General documents.