

Automatics

MultiBox III

Geovent MultiBox III is an advanced ventilation control, which is primarily used for constant pressure regulation (PID / differential pressure) of a fan, and it also has a built-in alarm system, telling the operator in case that it cannot reach the requested set point.

The MultiBox III is easy to install and has a user-friendly menu system, which lowers the installation costs.

By using the MultiBox III, will result in the fan constantly adjusting the speed according to the number of extraction points in use. By adjusting the power according to the necessary air flow, will result in lower running cost on the fan, and less of the heated (or cooled) indoor air is extracted.

The MultiBox III can further more give control signals to the central control unit / general AHU, and thereby lower the extraction air flow on the AHU (10-0V), as a slave of the airflow on the process ventilation system.

MultiBox III is recommended for:

- Frequency controlled extraction system (0-10V)
- Regulation of EC-motors in ventilation systems
- Regulation of dampers and Membrane dampers
- Supply air in balance with several process points
- Feedback regulation with up to 3 set points
- Slave control of supply air and room extraction
- Several switch options, for info to central systems, on usage, alarms, filter alarms etc.
- Pressure control in cabinets with supply and extraction air, why it is suitable as a feedback regulator and slave control for process ventilation.

Features:

MultiBox III has a built-in pressure sensor (1000 and 5000 Pa) and is supplied with 3 outputs and 3 inputs with sum-box. It can combine several supply and extraction systems and regulate according of up to 3 set points. Furthermore it has an alarm function, adjustable lower and upper levels. Akustisk alarm

User information is showed on a 2x16 dot display, which gives the user/installer useful information.

All functionalities on the MultiBox III is controlled by a powerful micro processor with a built-in EE-prom, which is used for storage of the software and the data/parameters, which are typed into it. When the processor and EE-prom are built-in, the risk of loss of data is lowered.



MultiBox III - Constant pressure regulation and pressure alarm

Ordering table

Art No.	Description
13-700	MultiBox III kan anvendes til trykmåling, styring, regulering (PID) og overvågning (med alarm) af anlæg for procesventilation i trykområdet 10-5000 Pa. MultiBox III har to valgfri driftområder; 10-1000Pa og 10-5000Pa og mulighed for invertering. Den kan kombinere flere udsugningsanlæg og indblæsning-sanlæg og regulere efter 3 setpunkter. Inkl. servicealarm, rød alarmlampe og sirene.

All vital components are well shielded against external electrical eruption/noise with both filter and fuse. The unit is CE-marked and EMC-tested.

An energy optimized system consist of the following Geovent components and has the following characteristics:

- All the dust and smoke has to be removed directly at the source
- The process ventilation is only active when there is a need
- All airflows are controlled after the actual needs
- Airflow is adjusted to the lowest possible level
- Balanced room extraction and supply air.
- The units capacity is designed according to the required average airflow
- All airflows are monitored by alarm limits

With differential pressure control on the ventilation system, the total energy consumption is lowered significantly, since there is only extracted the necessary air-flow. The speed on the fan is adjusted according to the number of extraction points that are in use. If you overlook the great savings on the electrical and heating bill, the following advantages are made

- Minimum size on the installed ventilation components
- Minimum air flow noise
- Minimum draft in the work area, as a result of lower airflows and air velocities.

The cost for the extra control automatics will normally be covered quickly by an increased savings on the running costs, and on the (smaller) component side. Over time, an investment in an energy optimized ventilation system, is almost always a good way to save money.

When ordering 1 pcs. MultiBox III:

- 1 pcs. MultiBox III incl. PG glands.
- 1 pcs. Measuring hose $\varnothing 6/4$ mm in 2 m length.
- 2 pcs. Rubber gland for fixing hose to duct.
- 7 pcs. Terminals for easy connection o cables.
- 1 pcs. Manual for MultiBox III.

Connection diagram for software version V530 and V630

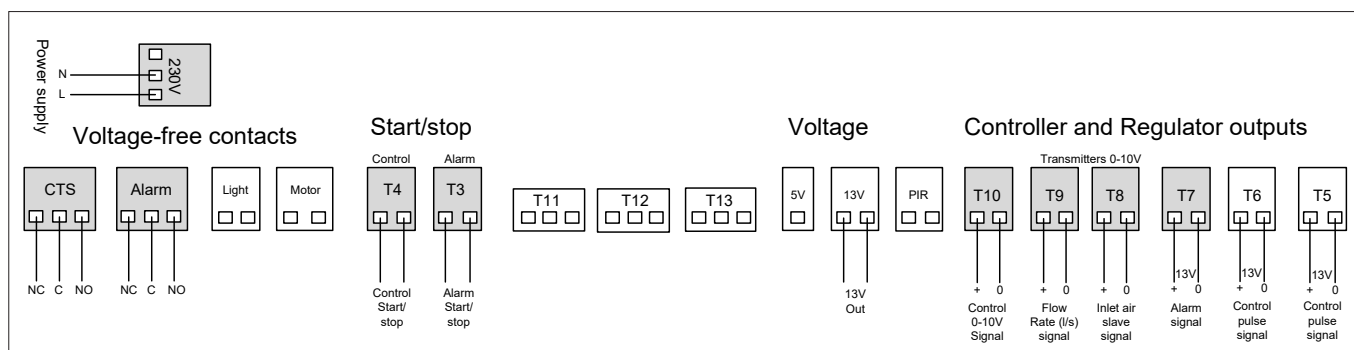

MultiBox III and Frequency Inverters