

111140E-12
2016-11

Spirit K2



E Installation instructions

Air handling unit with kitchen hood
and control panel

Contents

1	Installation/Preliminaries	4
1.1	Inspection/Maintenance	4
1.2	Space Required	4
1.3	Location requirements	4
2	Installation of Flexit SPIRIT K2 R	6
2.1	Installing the volume hood	6
2.2	Encasing	7
3	Connection of unit and electrical work	8
3.1	Connection of unit	8
3.2	Electrical work	8
3.3	Automatic Control	8
3.4	External components	8
4	Sizes/Physical Dimensions	9
4.1	Dimensioned sketch Flexit SPIRIT K2 R	9
5	General Drawings and System Drawings	10
6	Capacity and sound data	11
6.1	Capacity diagram, sound data, specifications - K2 R EC	11
7	Technical data	12
7.1	Technical data Flexit SPIRIT K2 R	12
8	Installation of control panel CI 60/600	13
8.1	Content	13
8.2	Installation of CI60/600	13
8.3	Concealed installation	14
8.4	Surface installation	14
8.5	Finishing off – CI60	14
8.6	Finishing off – CI600	14
9	Adjusting EC units	15
9.1	Adjustment with CI60	15
9.2	Adjustment with CI600	16
9.2.2	Temperature regulation	16
10	Adjusting the Kitchen Hood	17
10.1	Forced Ventilation	17
11	Adjustment Curves	17
11.1	Forced ventilation Flexit SPIRIT K2 R	17
12	Final checks/first use	18
13	EC Declaration of Conformity	19

*Our products are subject to continuous development and we therefore reserve the right to make changes.
We also disclaim liability for any printing errors that may occur.*

Important Safety Instructions:

It is the installer's responsibility to carry out a full safety and function assessment of the appliance

To reduce the risk of fire, electric shock or injury, read all the safety instructions and warning texts before using the appliance.

- This unit is only designed for ventilation air in buildings.
- Remove the power plug before commencing any service and maintenance work.
- Before opening the door, current to the unit must be turned off and the fans must have had time to stop (min. 3 mins.).
- The unit contains heating element which must not be touched when it is hot.
- The unit must not be operated without the filters being in place.

- There shall be adequate ventilation of the room when the range hood is used at the same time as appliances burning gas or other fuels.
- The air must not be discharged into flue that is used for exhausting fumes from appliances burning gas or other fuels.
- Accessible parts may become hot when used with cooking appliances.
- There is risk of fire if cleaning is not carried out in accordance with the instructions.
- Do not flambé under the range hood.
- Do not cook substances which could catch fire under the ventilator.
- Do not leave a saucepan or frying pan containing oil or grease unsupervised.
- Follow the instructions in the user manual.

To maintain good indoor air quality, comply with regulations and to avoid condensation damage the unit must never be stopped apart from during service/maintenance or in connection with an accident.

Symbols Used

These products bear a number of symbols used for labelling the actual product and in installation and user documentation.



EXAMPLE OF NIPPLE LOCATION (shown as right-hand model)



HIGH VOLTAGE



DANGER! DO NOT TOUCH



CAUTION When a text bears this symbol, it means that personal injury or serious damage to the equipment may result if the instructions are not followed.



NB! When a text bears this symbol, damage to equipment or a poor utilisation ratio may result if instructions are not followed.

This appliance can be used by children aged from 8 years and above and persons with reduced physical, sensory or mental capabilities or lack of experience and knowledge if they have been given supervision or instruction concerning use of the appliance in a safe way and understand the hazards involved. Note that the product is not intended for use by children.

Children shall not play with the appliance. Cleaning and user maintenance shall not be made by children without supervision.

Our products are subject to continuous development and we therefore reserve the right to make changes.

We also disclaim liability for any printing errors that may occur.

1 Installation/Preliminaries

See separate documentation for installation of ducts, valves, etc.

 The unit is designed for indoor installation.

1.1 Inspection/Maintenance

The unit must be installed with space for service and maintenance such as filter replacement and cleaning the fans and recovery system.

The control cable with plug for automatic control on top of the unit must be easily accessible.

1.2 Space Required

Type	A	B	C
K2 R	335 mm	2 x 2 mm	215-380 mm

A: Space in front of unit
 B: Space at side of unit
 C: Space above unit

These are minimum requirements and only take service needs into account. National statutory requirements for electrical safety may deviate from this. Check which rules apply in your country.

1.3 Location requirements

The unit has been designed for location in the kitchen over the cooker as it contains an integrated kitchen hood. The unit is available in left or right versions (exhaust air nipple to the left or right), depending on what is the most favourable in relation to the duct location.

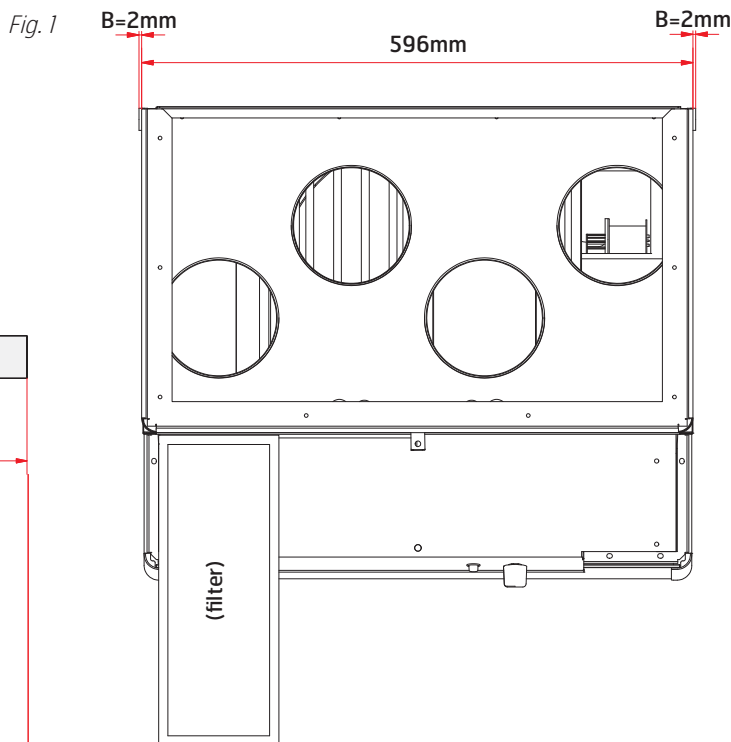
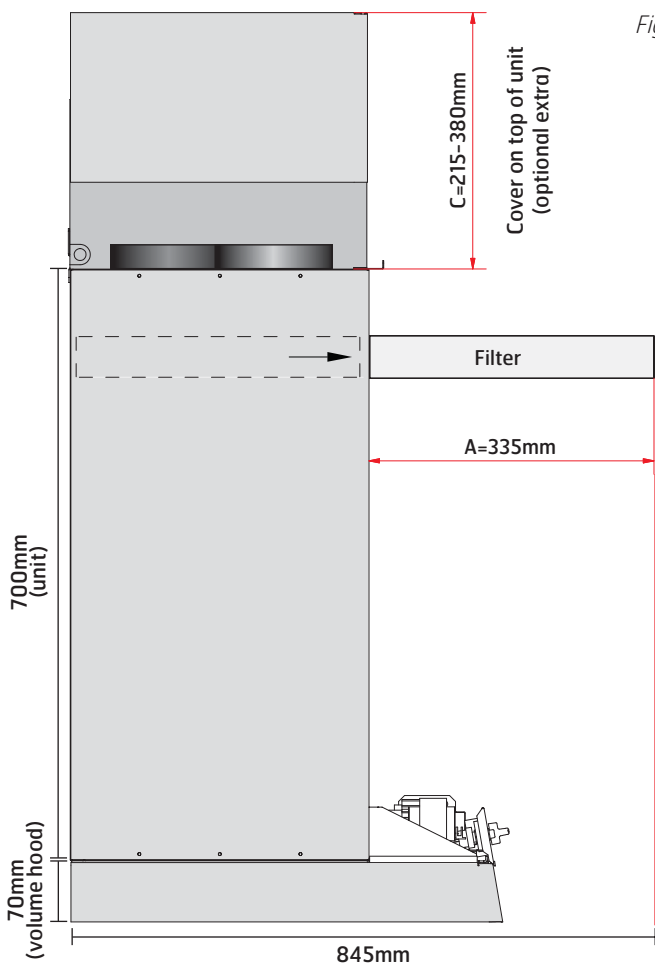

1.4 Recommended sound attenuation for wall-mounting

For wall mounting, the (included) wall bracket fixed to the unit is used.

The unit must not be placed on a wall with rooms on the other side which are sensitive to noise. The wall must be sound-insulated. If necessary, use double plasterboards on the wall.

Interrupted studs must be used.

Fig. 2

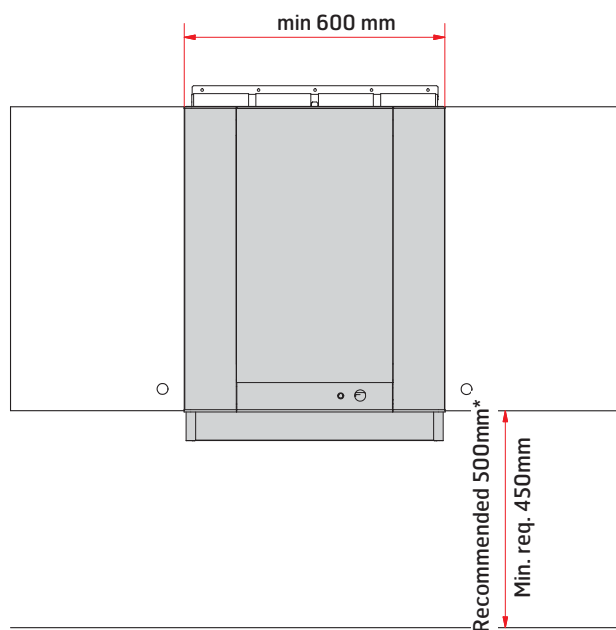

*min. req. 650mm for gas cookers



2 Installation of Flexit SPIRIT K2 R

Flexit SPIRIT K2 R is designed for installation in the kitchen above the cooker, see Fig. 2. The unit is supplied in left and right-hand versions depending on what suits duct locations best (Chap. 4.1).

The unit must be wall-hung from a mounting bracket (Fig. 6) at the top using the enclosed screws. It must also be screwed to the wall at the bottom edge of the unit. Remove 2 plastic plugs to access the mounting holes. For secure mounting, it is necessary to use extra nailing strips (noggins). The location of these is shown in Fig. 3.

NB! The wall must have good sound insulation, see Chap. 1.4.

The wall must be completely flat behind the ventilation unit. If the kitchen hood area is tiled, a suitable liner plate must be mounted behind the unit. The distance between the bottom of the grease filter and the cooker should be at least 50 cm for electric cookers and 65 cm for gas cookers. For the external dimensions of the unit, see the dimensioned drawing in Chap. 4.1.

2.1 Installing the volume hood

Fig. 3

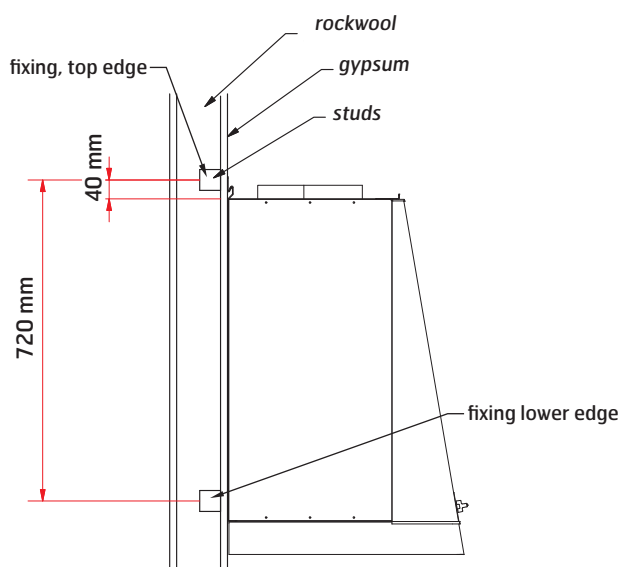
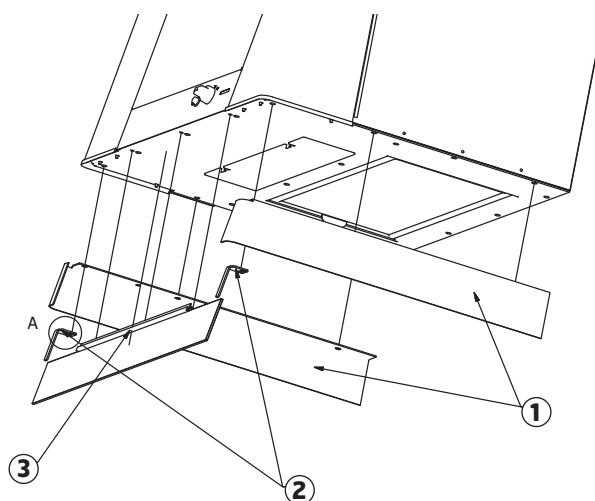

Fig. 4



1. Mount the two sides.
2. Attach the two angles.
3. Fix the glass profile.

Fig. 5

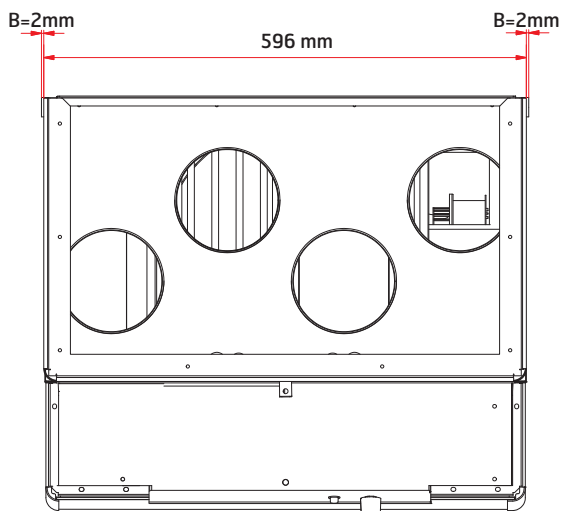
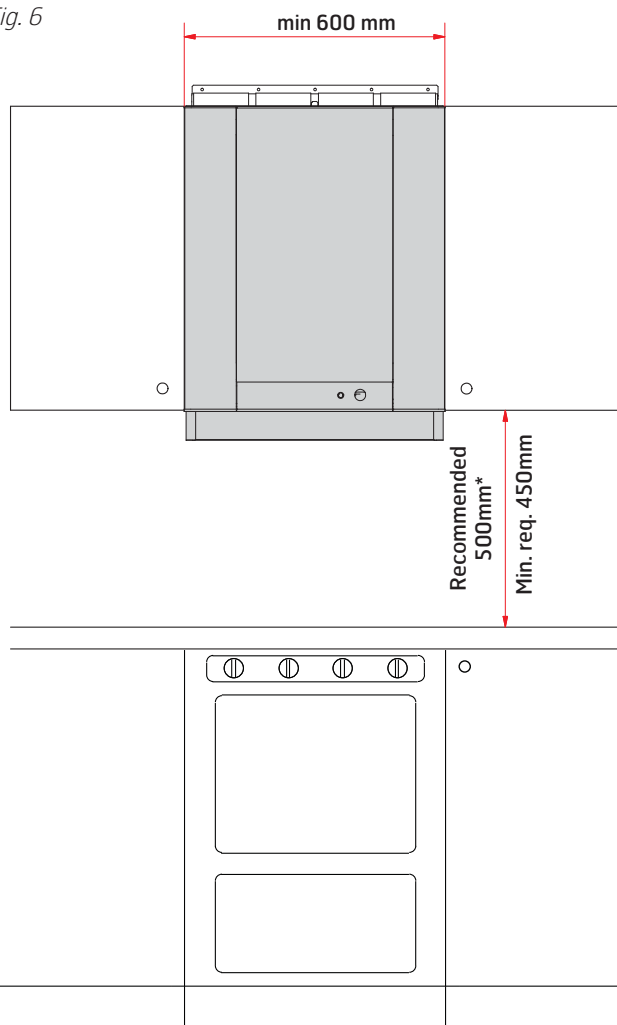

Fig. 6



*min. req. 650mm for gas cookers

2.2 Encasing

The casing must not be deeper than dimension A.

Fig. 7

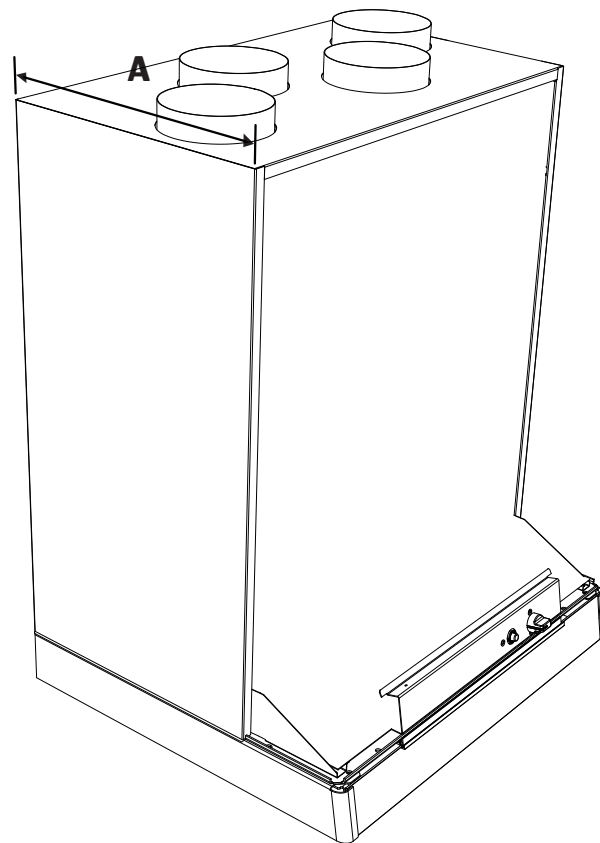

3 Connection of unit and electrical work

3.1 Connection of unit

- Ensure that the ducts arrive at the right muff coupling. See the marking on the unit (top/bottom and behind door). The symbols are explained on page 3 and the location is shown in the dimensioned drawing in Chap. 5.
- Pull the duct insulation well up to the unit.
- To avoid condensation, it is very important for the outdoor air duct and the exhaust air duct to have insulation and a plastic muff pulled right down to the unit.

NB! Use tape to seal the plastic sleeve to the unit but do not compress the insulation.

- Lay the outdoor air duct with a slight incline towards the outdoor air cap so that any water that enters drains out again.
- If there is a short distance between the unit and the exhaust point, sound insulation must be installed to ensure that the requirements for the outdoor sound level are met.
- Ducts must have good sound insulation, particularly above the unit.

3.2 Electrical work



All electrical work must be carried out by authorised personnel.



The unit must be installed with a separate earth leakage circuit breaker.

The unit is supplied with a 1.8 m cable with plug.

The cable leaves the top of the unit and is connected to a 230V 50 Hz single-phase earthed power point located within a convenient distance. The plug must be used as a service switch.

NB! Make sure the power point for the unit is not boxed in.

See Chap. 13 for fuse sizes.

A low-voltage cable (with connector) leaves the unit for use on the control panel. It is important to retain easy access to this plug - in case of any fault or when replacing the unit.

3.3 Automatic Control

The control pack is included in the unit package. The low-voltage cable must be laid between the unit and the switch unit. See separate manual for automatic control included in pack.



The low-voltage cable must be laid minimum 30 cm from the 230 V cable and in the case of chased mounting be laid in 20 mm electrical piping. The cable length must not exceed 24 meters.

3.4 External components

See wiring diagram enclosed with unit.

5 General Drawings and System Drawings

General Diagram (Rotary Wheel-type Heat Exchanger)

- 1 (F12) Extract filter F 7
- 2 (F11) Supply air filter F 7
- 3 (EB1) Heating element
- 4 (F10-20) Overheating thermostat (heating) (Reset)
- 5 (M1) Supply air fan
- 6 (M2) Extract air fan
- 7 (HR-R) Rotary wheel-type heat exchanger
- 8 (M4) Rotor motor
- 9 Control unit
- 10 Kitchen hood
- 11 Damper adjustment

(Shown as left-hand model. The right-hand version is a mirror image.)

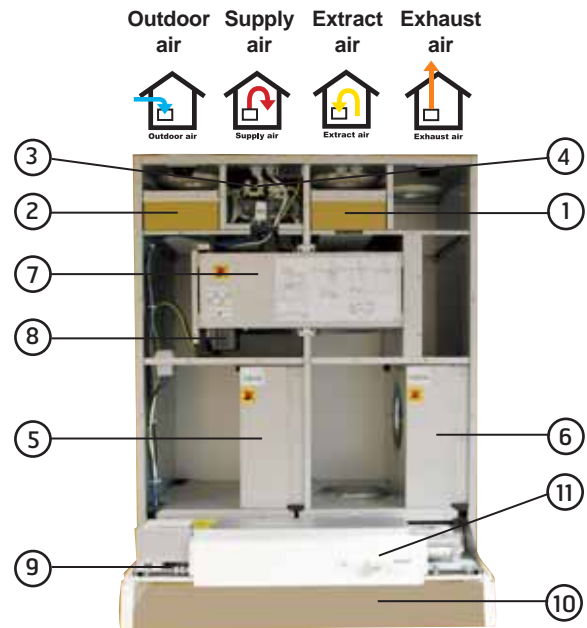

System drawing (electric battery)

- B1 Supply air temperature sensor
- EB1 Heating element
- F10 Overheating thermostat, manual reset
- F20 Overheating thermostat, automatic reset
- F11 Supply air filter
- F12 Extract air filter
- M1 Supply air fan
- M2 Extract air fan
- HR-R Rotary wheel-type heat exchanger
- M4 Rotor motor
- K Kitchen hood
- DA4 Damper

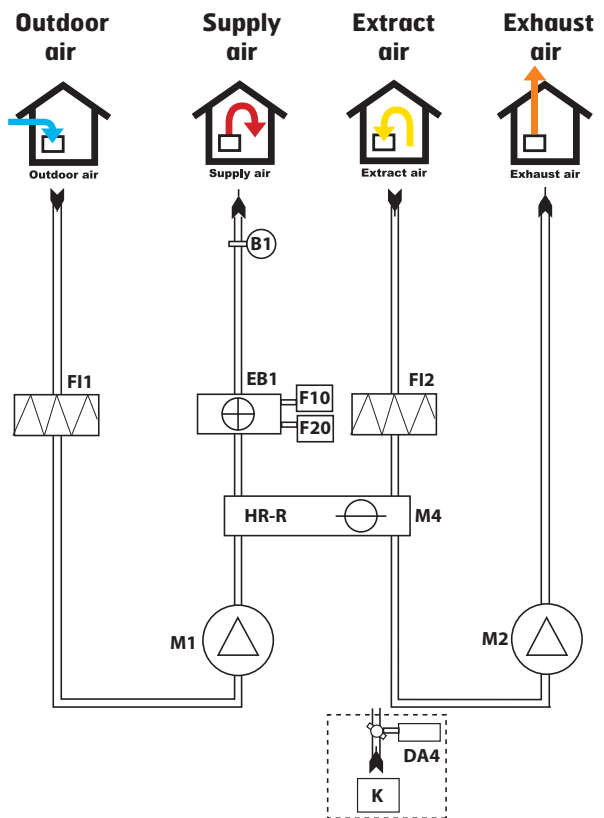

6 Capacity and sound data

6.1 Capacity diagram, sound data, specifications - K2 R EC

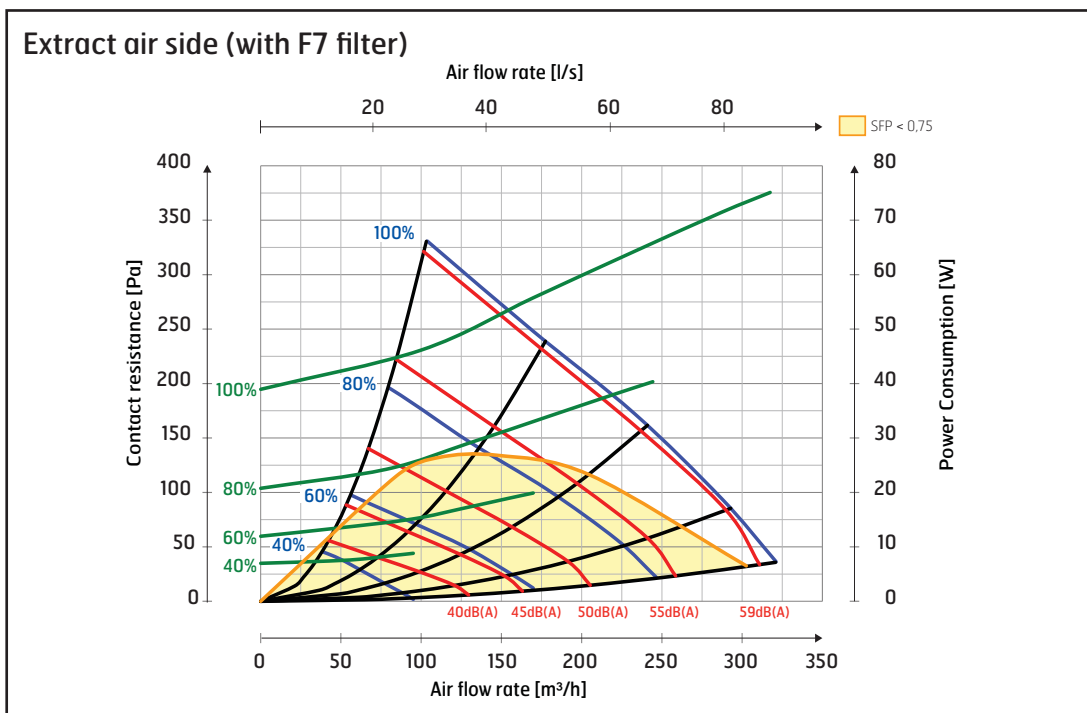
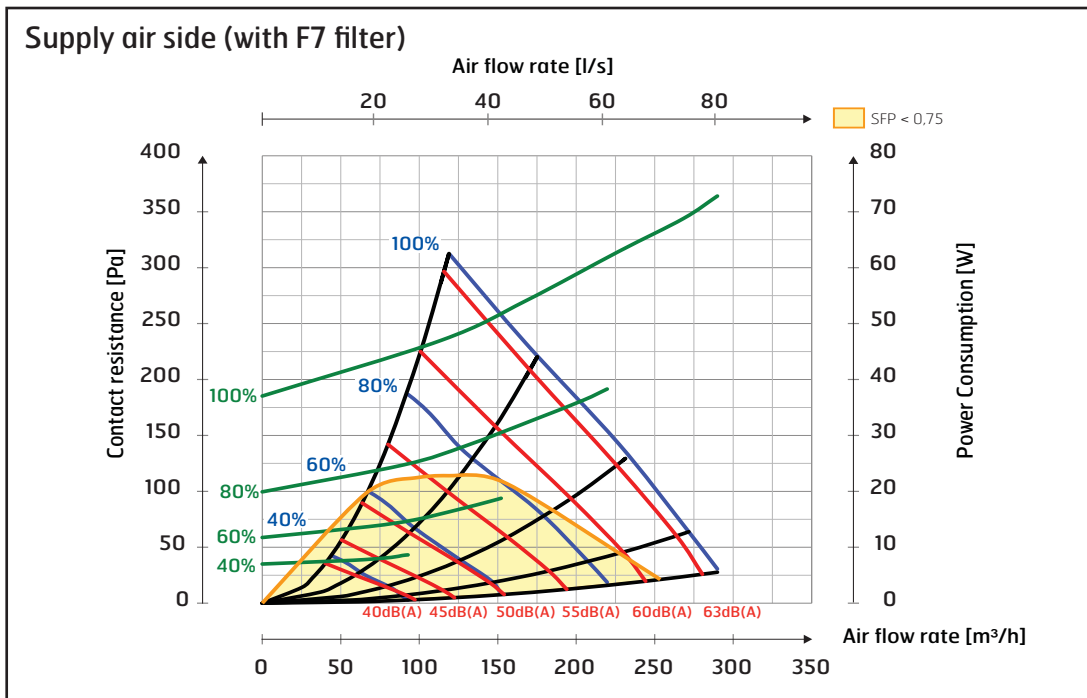

Sound data is given at sound power level L_w in the capacity diagrams and is corrected with the table below for the various octave bands. Radiated noise produces L_w in the various octave bands and total L_w . This is read directly from the supply air table.

Correction factor for L_w

Hz	63	125	250	500	1000	2000	4000	8000	L_w
Supply air	14	12	1	-6	-7	-15	-22	-26	
Extract air	14	13	0	-5	-10	-16	-25	-28	
Radiated 1	-4	-7	-12	-19	-27	-32	-32	-34	-16
Radiated 2	3	-5	-17	-23	-29	-32	-37	-35	-18

Data for supply air is measured in accordance with ISO 5136, "In-duct method". Radiated noise is measured in accordance with ISO 9614-2. Bruel & Kjaer measuring equipment, type 2260.

Air capacity at various capacity settings in %
Supply air fan power consumption at various capacity settings.
Sound power level L_w , cf. correction table.

Radiated 1: K2 free hanging
Radiated 2: K2 built-in kitchen

7 Technical data

7.1 Technical data Flexit SPIRIT K2 R

	EC	EC
	700W	350W
Rated voltage	230 V/50 Hz	230 V/50 Hz
Fuse size	10 A	10 A
Rated current, total	3,91 A	2,1 A
Rated power, total	870 W	495 W
Rated power, electric batteries	700 W	350 W
Output fans	2 x 74 W	2 x 74 W
Fan type	F-wheel	F-wheel
Fan motor control	0-10 V	0-10 V
Max. fan speed	1,970 RPM	1,970 RPM
Automatic control standard	CS 50	CS 50
Filter type (SUP/EXTR)	F7/F7	F7/F7
SUP filter dimensions (WxHxD)	130x335x50 mm	130x335x50 mm
EXTR filter dimensions (WxHxD)	130x335x50 mm	130x335x50 mm
Weight	56 kg	56 kg
Duct connection	Dia. 125 mm (sleeve)	Dia. 125 mm (sleeve)
Duct connection kitchen fan		
Height	700 mm*	700 mm*
Width	598 mm	598 mm
Depth	510 mm**	510 mm**

* without volume hood and duct connection, see Chap. 5

** see Chap. 5

8 Installation of control panel CI 60/600

8.1 Content



1. Control panel
2. Back piece for concealed installation
3. Back piece for surface installation
4. Installation instructions
5. Cable for control panel

8.2 Installation of CI60/600

CAUTION! The control panel must be connected to the ventilation unit before the ventilation unit is connected to mains.

Lay the cable for the control panel between the ventilation unit and the control panel. The control panel is adapted for concealed installation over a single connection box (use low back piece, item no. 2) or surface installation on the wall (use high back piece, item no. 3).

Click the cable into the contact at the back of the control panel and into the contact on the top of the ventilation unit.

Fig. 8

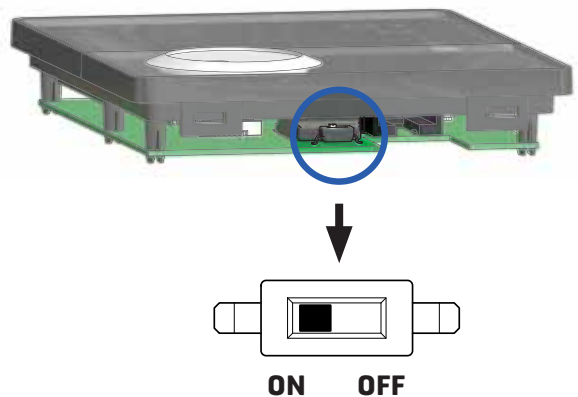

OBS! The low-voltage cable must be at least 30 cm from cables carrying mains voltage or higher. With concealed installation, the cable is laid in 20 mm conduit pipes. The cable length must not exceed 24 meters.

It is possible to connect two CI60 panels and one CI600 panel to each unit. If several CI60 panels are used, each panel must have its own identity. This is selected with the switch on the panel's printed circuit board (see Fig. 27). Use the appropriate table settings. The panels can be connected serially, in arbitrary order.

OFF = MASTER
ON = SLAVE

Configuration	Setting
CI 600 (MASTER)	Automatic
CI60 1 (SLAVE)	OFF
CI60 2 (SLAVE)	ON
CI60 1 (MASTER)	OFF
CI60 2 (SLAVE)	ON
CI 600 (MASTER)	Automatic
CI60 (SLAVE)	Irrelevant

8.3 Concealed installation

Lay the cable between the wall box and the ventilation unit in the preinstalled conduit pipe. Fit the back piece (item no. 2), over the wall box and click the cable in directly from behind as in the illustration (see Fig. 9).

Fig. 9



8.4 Surface installation

Lay the cable between the back piece (item no. 3), and the ventilation unit. Cut out the perforation in the corner of the back piece that is suitable for installation. Screw the back piece to the wall with suitable screws. Click the cable into the control panel from below, where there is a socket in the printed circuit board (see Fig. 10).

Fig. 10



8.5 Finishing off – CI60

Slide the panel off as shown by arrow no. 1 (see Fig. 11) and fit the control panel straight into the back piece as shown by arrow no. 2 (see Fig. 12) until it clicks into place. Slide the panel back on.

Fig. 11

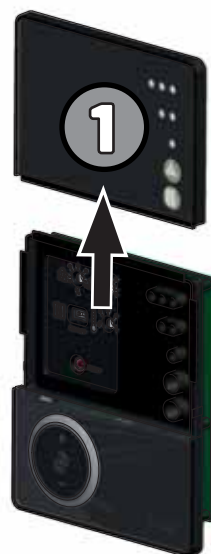
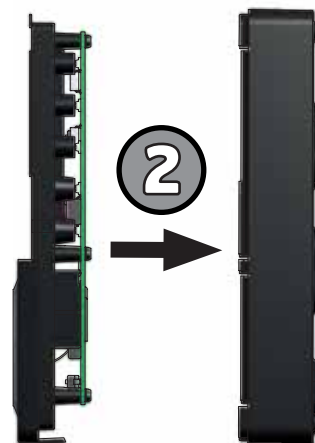

Fig. 12



8.6 Finishing off – CI600

Fit the control panel over the hooks in the back piece as shown by arrow no. 1 and then click the panel into place at the bottom edge as shown by arrow no. 2 (see Fig. 13).

Fig. 13



9 Adjusting EC units

9.1 Adjustment with CI60

The unit's air supply **MUST** be adjusted before the unit is used for the first time. This should be done in accordance with the projection documents. Adjust the values based on the projected values.

9.1.1 Adjustment

Only stage 2 (NORMAL) needs to be adjusted. Stages 1 and 3 have fixed settings, while stage 2 has to be adjusted as required in the individual home.

The function of the different stages:

MIN	Must not be used when the home is in use. Must not be used in the first two heating seasons.
NORMAL	Used under normal conditions. On this setting the air supply must be adjusted according to current regulations.
MAX	Used if there is a need for increased air supply on account of higher occupancy or a raised humidity level, for example during showering or when clothes are being dried. This setting is normally used for limited periods.

The ventilation unit's air supply is adjusted in speed level NORMAL using the knobs on the back of the cover. Knob 9 is used for supply air level and knob 8 for extract air level (see Fig. 14). The adjustment range is 20-100% of the maximum level according to the scale on the knob.

Factory settings for supply air/extract air:

MIN	50% (fixed)
NORMAL	75% (variable)
MAX	100% (fixed)

9.1.2. Adjusting the temperature

The temperature required for the supply air can be set with knob 11. The adjustment range is 10 - 30°C. It should normally be set to around 18°C. Use of the factory setting is recommended.

If necessary, the ventilation unit's additional heating can also be switched ON/OFF with switch 10. In this case only the rotating heat exchanger is used as a source of heat. It is best to leave it in ON position, as the unit will then respond automatically when there is a need for additional heating.

Fig. 14

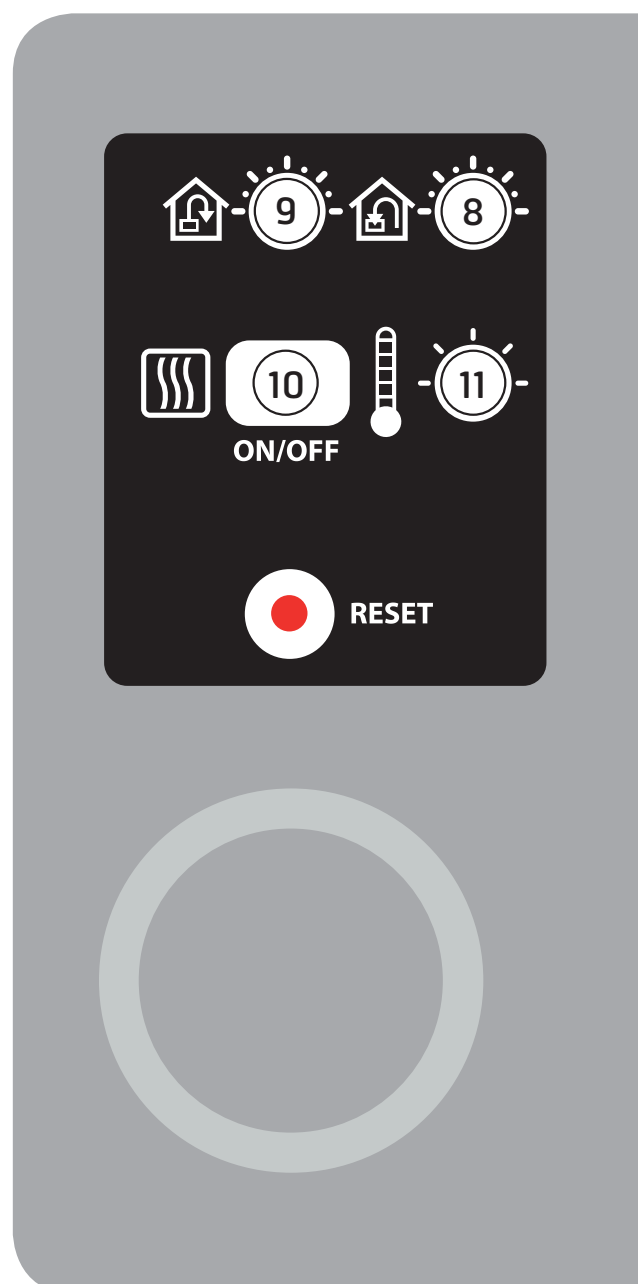

9.2 Adjustment with CI600

 The unit's air supply **MUST** be adjusted before the unit is used for the first time. This should be done in accordance with the projection documents. Adjust the values based on the projected values.

9.2.1 Adjustment

Only stage 2 (NORMAL) needs to be adjusted.

Note that it is also possible to adjusted stages 1 and 3 with a CI600 control panel. This should only be done if a special need arises, however. This is because it is extremely important to have adequate air flow rates.

The function of the different stages:

MIN	Must not be used when the home is in use. Must not be used in the first two heating seasons.
NORMAL	Used under normal conditions. On this setting the air supply must be adjusted according to current regulations.
MAX	Used if there is a need for increased air supply on account of higher occupancy or a raised humidity level, for example during showering or when clothes are being dried. This setting is normally used for limited periods.

First go to the "Advanced user" menu, enter the PIN and press OK:

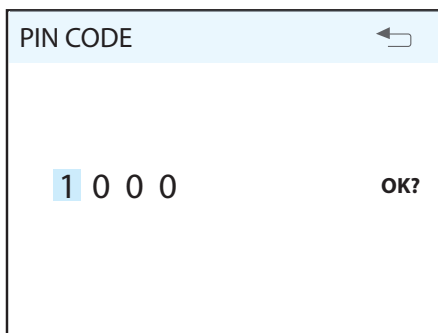

Then go to the "Fan control" menu. The fans are selected and configured in this menu screen. Then go to adjustment of the extract air fan and supply air fan.

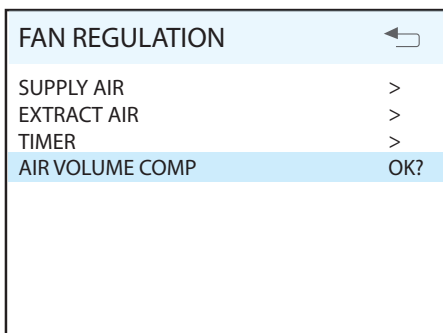

This dialog is identical for the supply air and extract air fans. The fans are adjusted individually to the desired capacity for the respective speed.

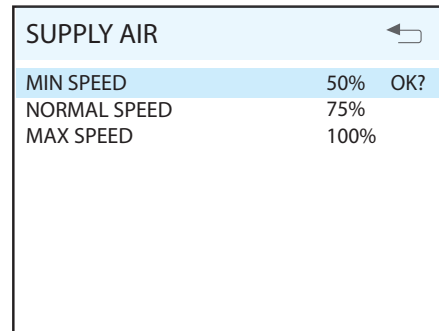

Factory settings for supply air/extract air:

MIN	50% (variable)
NORMAL	75% (variable)
MAX	100% (variable)

9.2.2 Temperature regulation

In this menu screen (located under "Advanced user") you configure the temperature regulation and cooling functions.

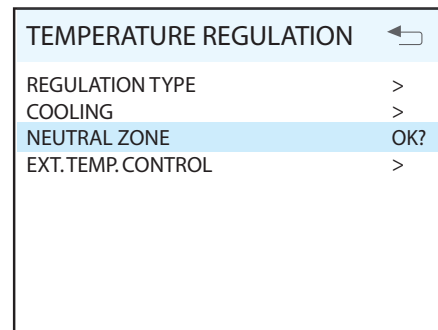

Regulation type

If supply air regulation is selected, no further settings can be set here. If extract air regulation is selected, the max. and min. supply air temperatures can also be specified.

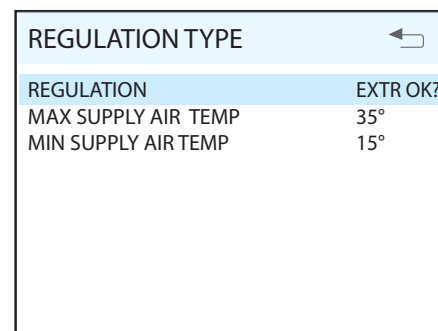

10 Adjusting the Kitchen Hood

If basic ventilation is desired via the kitchen hood, the damper from the factory must be replaced. Replace it with a damper with adjustment options. This is not supplied with the unit.

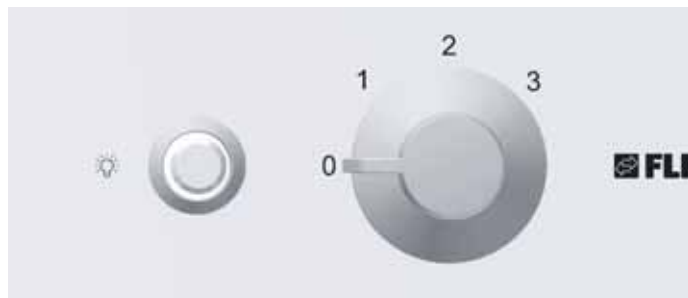

Fig. 16

10.1 Forced Ventilation

The unit has 4 forced ventilation options:

1. (Switch on front of unit.) This gives a half-open damper which will increase the air volume passing through the hood.
2. Turn the knob to position 2. This gives a fully open damper which will allow even more air through the kitchen hood.
3. Turn the knob to position 3. This will give a fully-open damper which will allow even more air through the kitchen hood, in that the fans go to speed 3.
4. The air volume through the unit can also be increased by setting the fans to speed 3 via the control panel (external panel). See separate instructions.

The damper needs closing again manually. There is no timer in the damper. Closed in position 0.

The air entering the unit through the kitchen hood does not pass through the rotary heat exchanger (by-pass).

11 Adjustment Curves

11.1 Forced ventilation Flexit SPIRIT K2 R

Max. air volume through kitchen hood in case of forced air volume

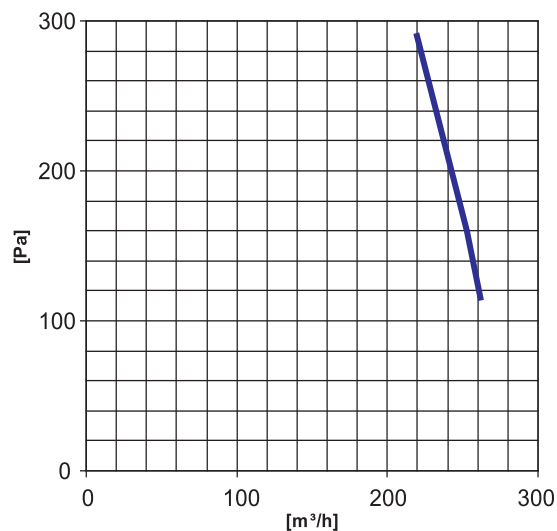

Measurements have been taken at 2/3 pressure in the extract air duct and 1/3 pressure in the exhaust air duct before opening the damper.

12 Final checks/first use

12.1 Final Checks

Check that:

- The duct insulation is in accordance with the manual and the technical documents. It is very important the ducts from the unit are also effectively insulated so that no condensation forms on or in the ducts. It is especially important to check this if the ducts are to be boxed in.
- Ducts are connected to the right nipples – check against the unit drawings below.
- Adjustments have been made in accordance with the manual and project planning documents (documentation of ventilation data).
- The unit operates normally at all stages.
- Heating switches in.
- The unit has filters for both outdoor air and extract air.
- Tumble dryers must not be connected to the unit.



The installer may be held liable for any incorrect or defective installation.

12.2 First use

- Check that the control panel has been connected.
- Plug the unit into the mains supply.
- The unit will now start.
- The unit will automatically perform a start-up procedure lasting approx. 2 min.
- After the start-up procedure the unit will follow the settings entered on the control panel.
- If it is wished to check or alter the settings, this can be done from the control panel.
(See separate documentation for automatic control.)

Flexit SPIRIT K2 R, Left-hand model



Flexit SPIRIT K2 R, Right-hand model

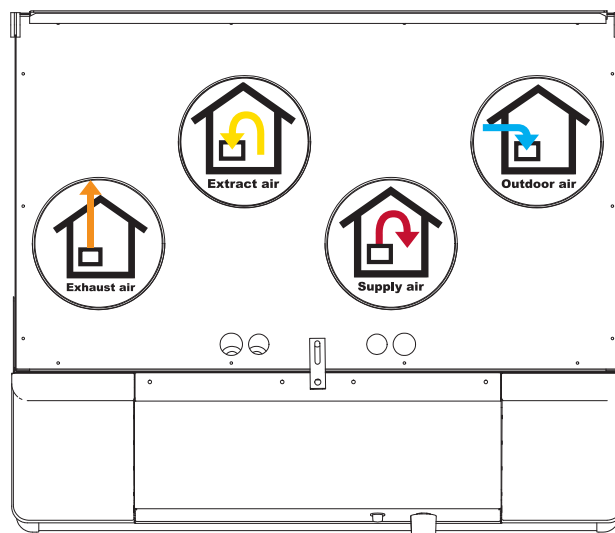

13 EC Declaration of Conformity

This declaration confirms that the products meet the requirements in the following Council Directives and standards:

2014/30/EC Electromagnetic Compatibility (EMC)
2014/35/EC Low-voltage Directive (LVD)
1253/2014 Ecodesign regulation
1254/2014 Energy labelling regulation

Our products have been tested in accordance with parts of:
2006/42/EC Machinery Directive (Safety)

Manufacturer: FLEXIT AS, Televeien 15, 1870 Ørje, Norway

Type: K2 R Ventilation unit

Compliance with valid versions of the following standards on the date on which the declaration of conformity was signed:

Safety standards:	EN 60335-1 EN 60335-2-31
EMF standard:	EN 62233
EMC standard:	EN 55014-1 EN 55014-2 EN 61000-3-2 EN 61000-3-3

The product has been CE-marked: 2011

FLEXIT AS 29.11.2016



Frank Petersen
CEO

The right to give notice of lack of conformity applies to this product in accordance with the existing terms of sale, **provided that the product is used and maintained correctly.** Filters are consumables.



The symbol on the product shows that this product must not be treated as household waste. It must be taken to a reception station for recycling of electric and electronic equipment.

By ensuring the correct disposal of the equipment, you will contribute to preventing the negative consequences for the environment and health that incorrect handling may entail. For further information on recycling of this product, please contact your local authority, your refuse collection company or the company from which you purchased it.

Notice of lack of conformity as a result of incorrect or defective installation must be submitted to the installation company responsible. The right to give notice of lack of conformity may lapse if the system is used incorrectly or maintenance is grossly neglected.



Flexit AS, Televeien 15, N-1870 Ørje www.flexit.no