

LCPB

with straight radial blades

Description

Applications

Low-pressure radial fan designed for the conveyance of air or gas-flow which is corrosive, dust-polluted or explosive.

General specifications

- LCPB is fitted with a circular inlet and rectangular outlet connectors. Manufactured in PVC, PP, GRP and PPS-EL
- fitted with straight radial blades with shroud plate, T impeller
- operates within a range of flow of up to 30 m³/s and range of pressure of up to approximately 2000 Pa
- suitable for indoor and outdoor installation
- manufactured in ten different sizes
- can be supplied with direct drive up to size 056 or belt drive; alternatively, fitted with a two-speed motor
- stand made of steel with painted surface finish in accordance with VV-AMA 83, environmental standard M3.



Standard sizes

LCPB fans are manufactured in ten different sizes: 040, 045, 050, 056, 063, 071, 080, 090, 100 and 112. The designations refer to the inlet dimensions in centimetres.

Belt drive assembly

Two types of belt drive are available:

- with steel bar base plate with the motor mounted on the angled side of stand (motor weight max. 70 kg).
- with steel bar base plate with fan and motor mounted side-by-side.

Program text

Radial fan, Arex model LCPB, with fan impeller with straight radial blades and shroud plate. Impeller and casing shall be manufactured in PVC, GRP, PP or PPS-EL (i.e. electro-conductive, self-extinguishing polypropylene).

Outlet position

The illustrations below show the fans from the drive side. RD stands for right and LG for left-handed layout.

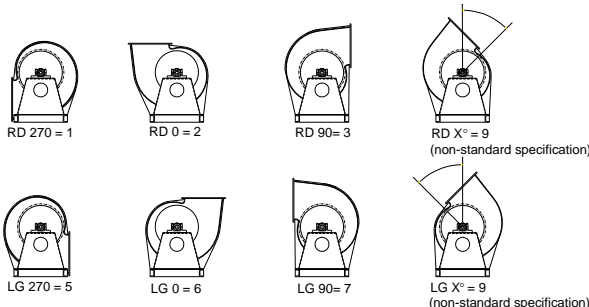

Specifications

LCPB		-XXX-XX-X-X-X
Sizes	040, 045, 050 056, 063, 071 080, 090, 100, 112	}
Drive type	10= Belt drive, motor on side of stand 11= Belt drive, motor on base plate 40= Direct drive 1400 rpm 60= 900 rpm 80= 700 rpm 46= 1400/900 rpm 48= 1400/700 rpm	
Outlet position	1, 2, 3, 5, 6, 7, 9 See illustration below	}
Materials, casing	0=PVC, 1=GRP, 2=PP Various materials, 4=PPS-EL	
Materials, impeller	See materials, casing	}

LCPB

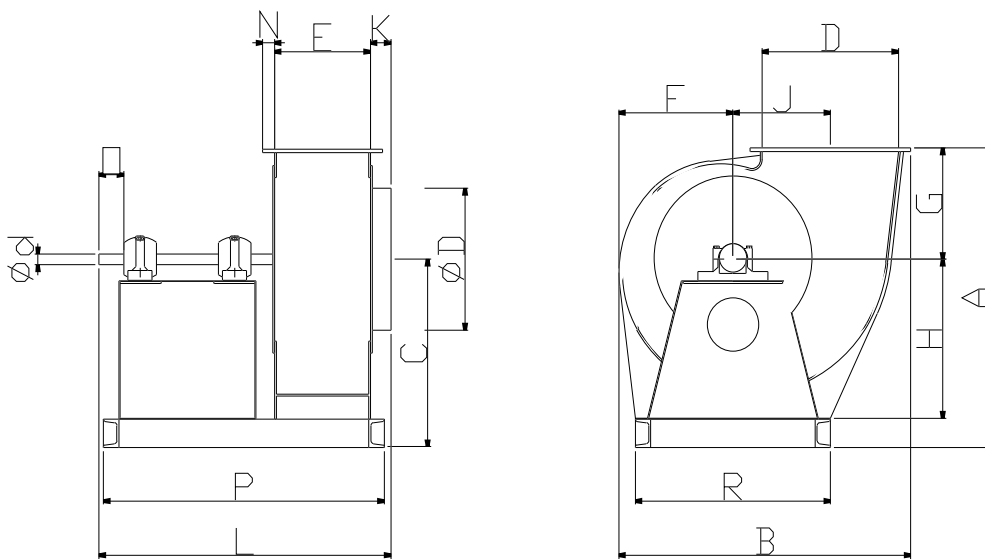

LCPB	A	B	C	D	d	E	F	G	H	J	K	L	N	O	P	R	kg
	mm	mm	mm	mm	mm	mm	mm	mm	mm	mm	mm	mm	mm	mm	mm	mm	
040	840	860	530	400	30	280	340	310	450	285	60	865	35	80	820	570	70
045	880	995	530	450	35	315	415	350	450	315	60	965	40	92	910	630	80
050	975	1065	580	500	35	355	420	395	500	355	60	1005	40	92	950	710	95
056	1085	1190	640	560	40	400	470	445	560	400	80	1165	40	107	1080	800	115
063	1205	1330	710	600	45	450	525	495	630	450	80	1235	40	117	1140	900	135
071	1345	1495	790	700	50	500	550	555	710	505	80	1405	40	135	1300	1040	160
080	1510	1670	880	800	55	560	665	630	800	565	80	1470	40	150	1440	1140	195
090	1680	1890	980	900	60	630	765	700	900	635	120	1675	40	165	1520	1300	240
100	1880	2125	1080	1000	65	710	885	800	1000	700	120	1845	40	150	1700	1500	280
112	2100	2365	1200	1120	70	800	920	900	1120	780	120	2015	45	150	1900	1700	330



LCPB 040

Mtrl 1 < 2500 r/m

Mtrl 0,2,3,4 < 1750 r/m

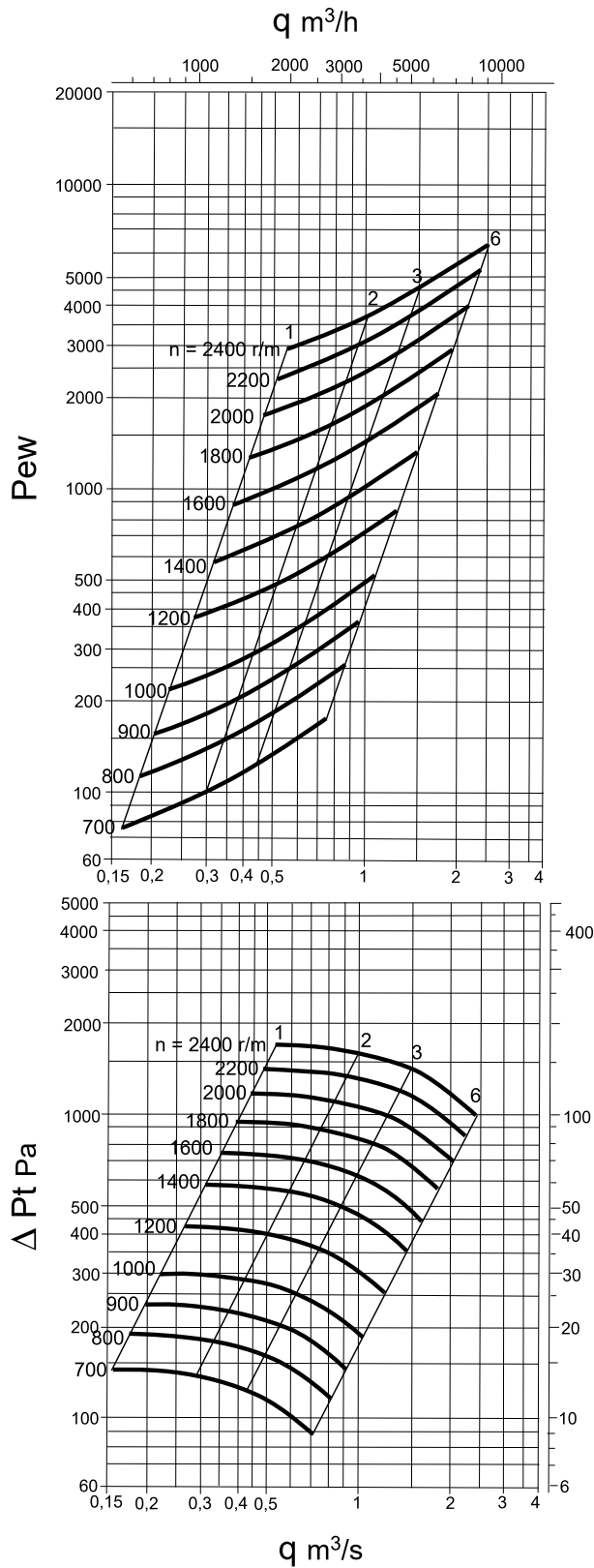

LCPB 045

Mtrl 1 < 2250 r/m
 Mtrl 0,2,3,4 < 1550 r/m

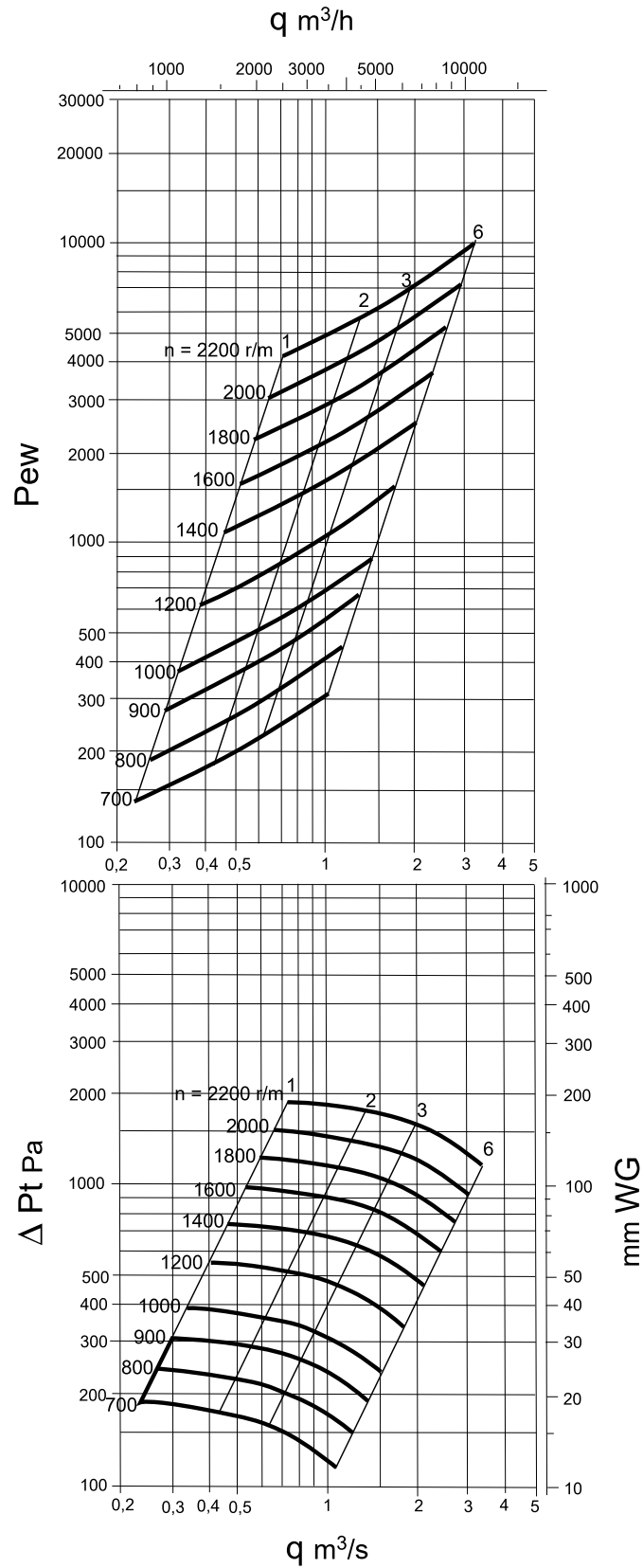



LCPB 050

Mtrl 1 < 2000 r/m
Mtrl 0,2,3,4 < 1350 r/m

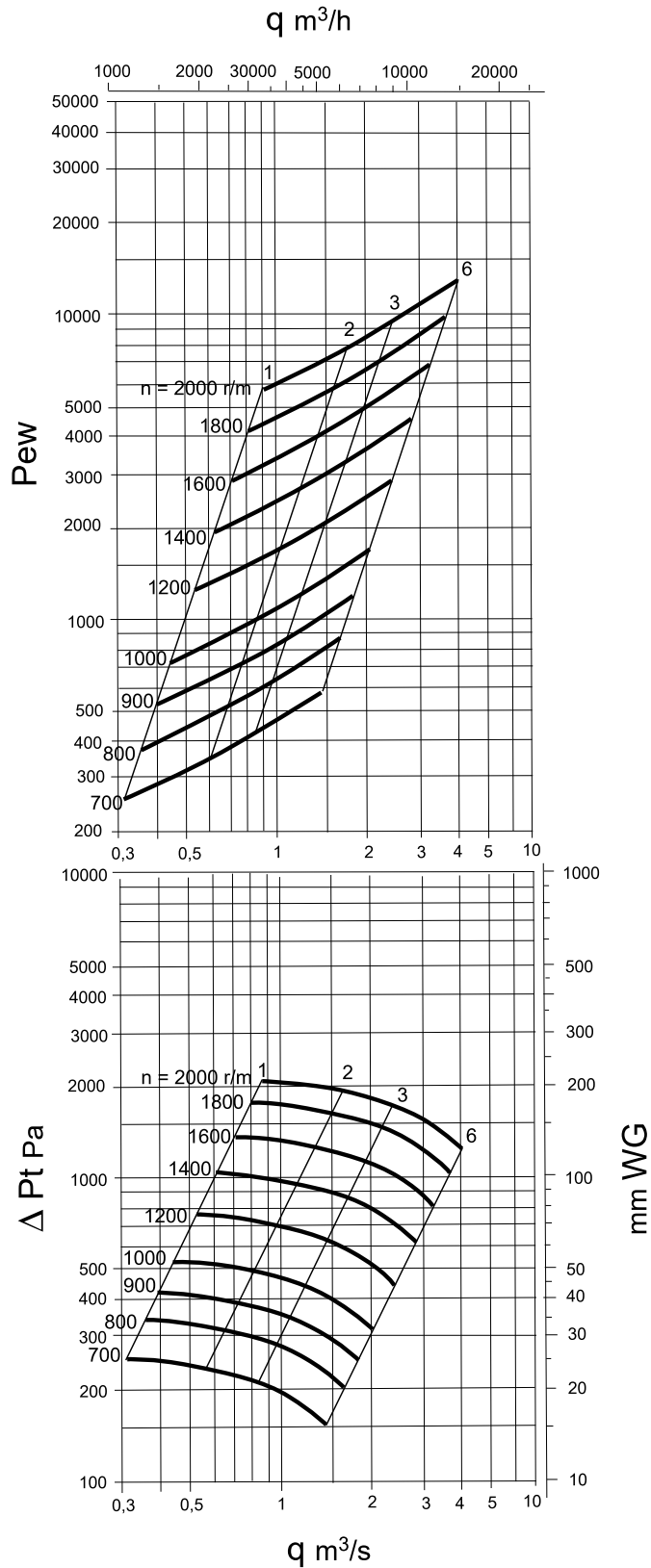

LCPB 056

Mtrl 1 < 2000 r/m
 Mtrl 0,2,3,4 < 1200 r/m

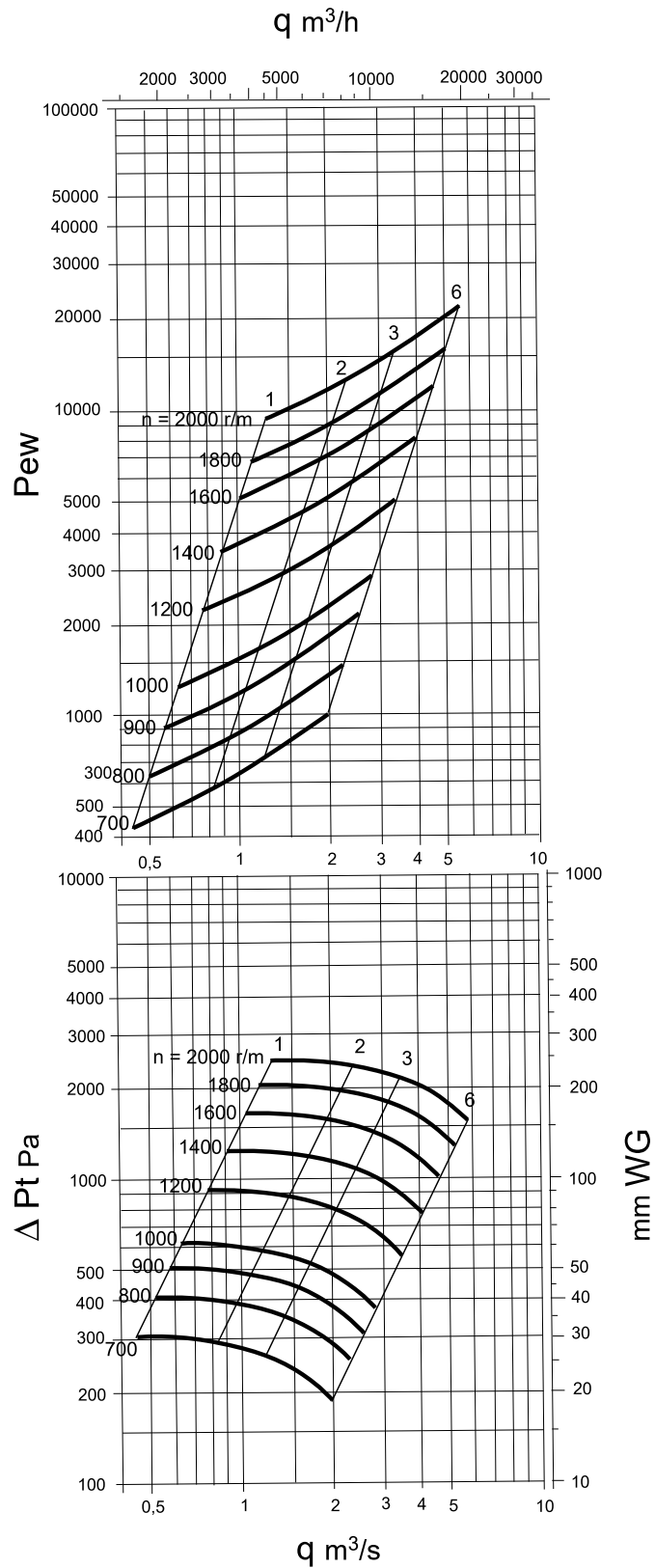



LCPB 063

Mtrl 1 < 1600 r/m
Mtrl 0,2,3,4 < 1050 r/m

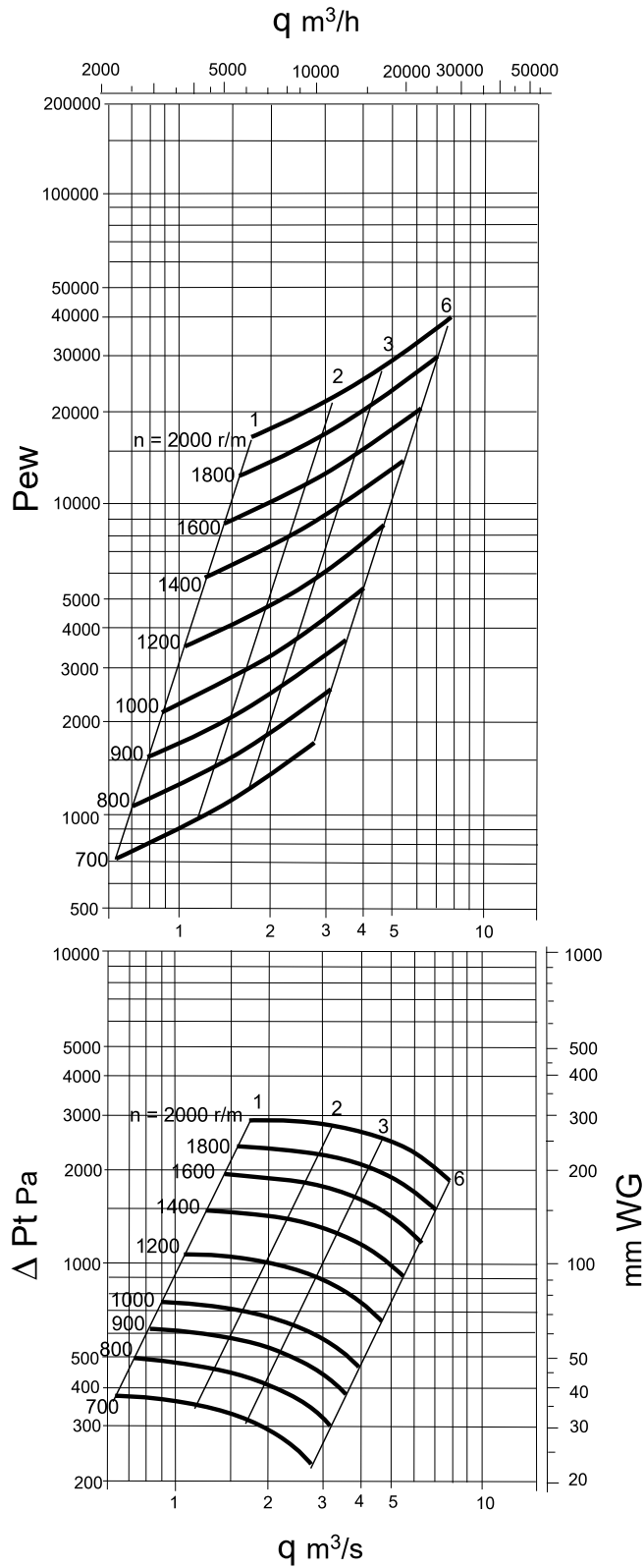

LCPB 071

Mtrl 1 < 1400 r/m
 Mtrl 0,2,3,4 < 950 r/m

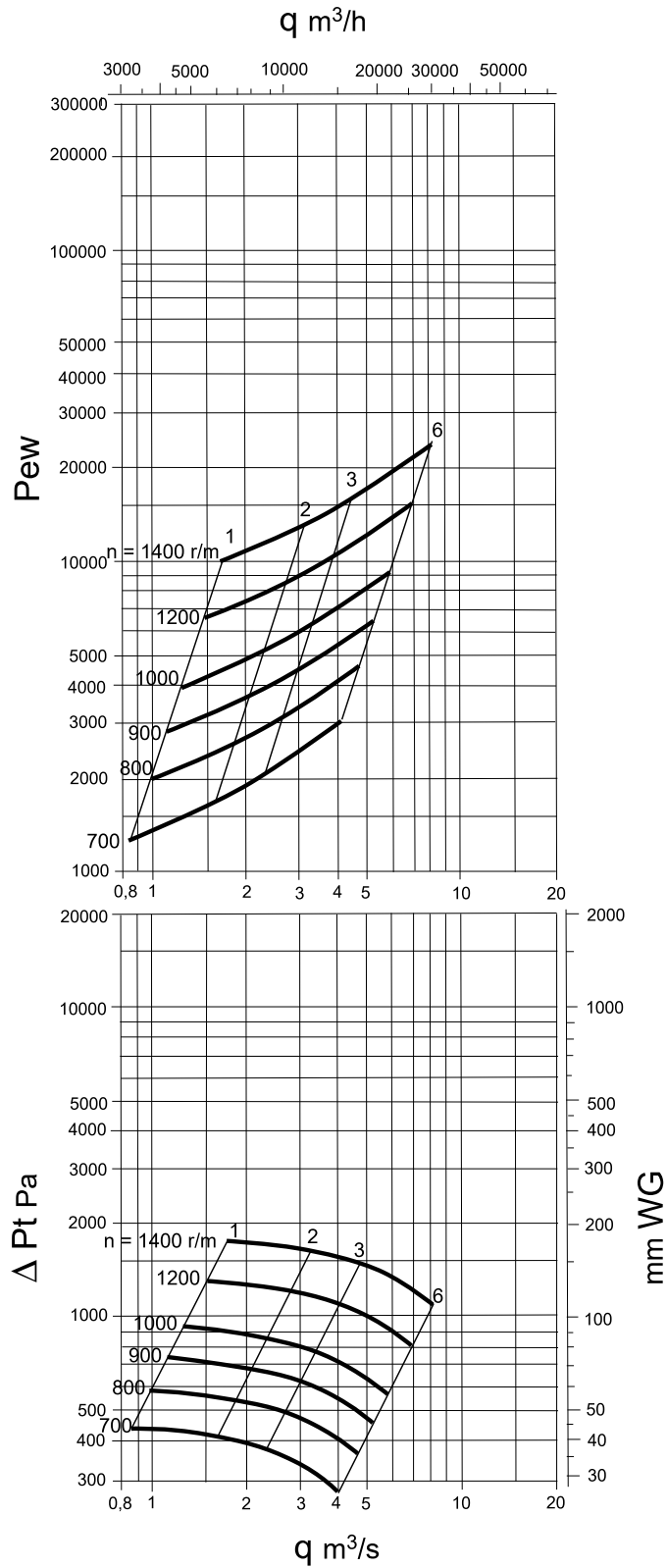

LCPB 080

Mtrl 1 < 1250 r/m
 Mtrl 0,2,3,4 < 850 r/m

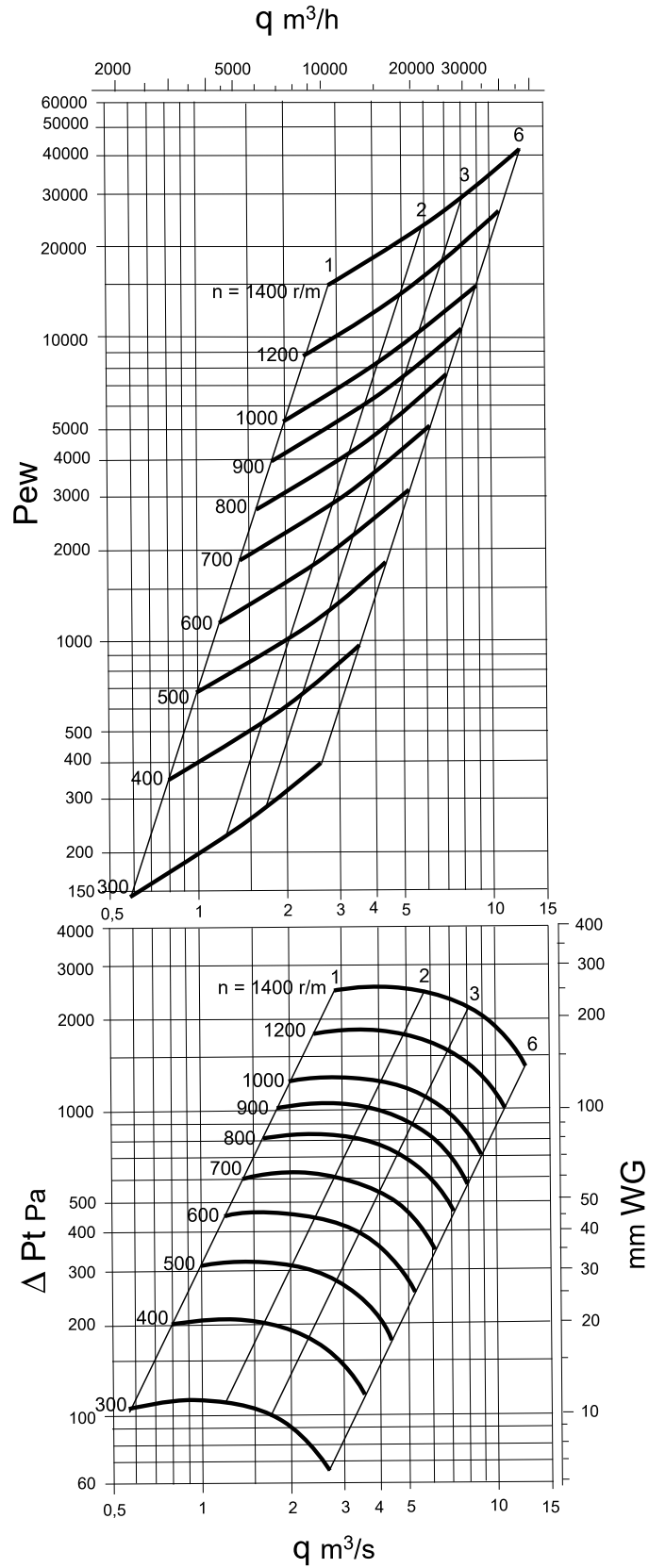

LCPB 090

Mtrl 1 < 1200 r/m
 Mtrl 0,2,3,4 < 750 r/m

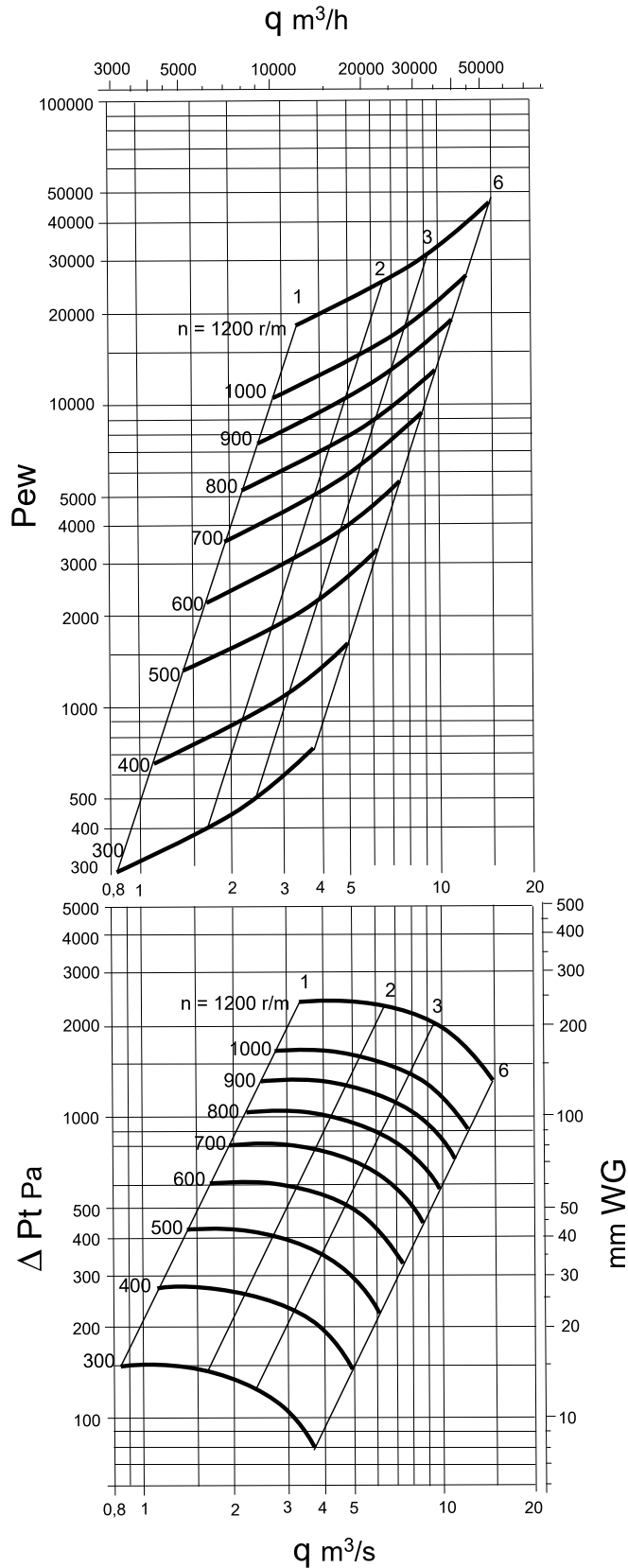



LCPB 100

Mtrl 1 < 1000 r/m
 Mtrl 0,2,3,4 < 650 r/m

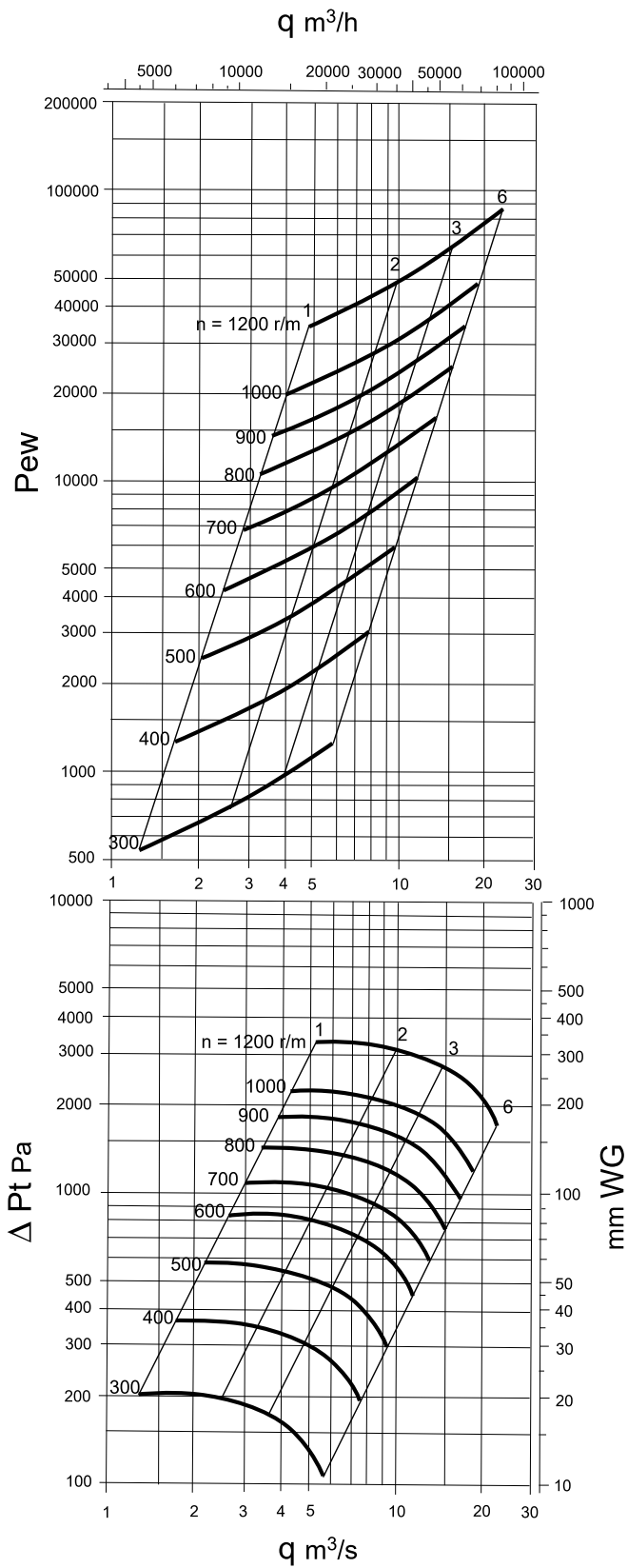

LCPB 112

Mtrl 1 < 900 r/m
 Mtrl 0,2,3,4 < 600 r/m

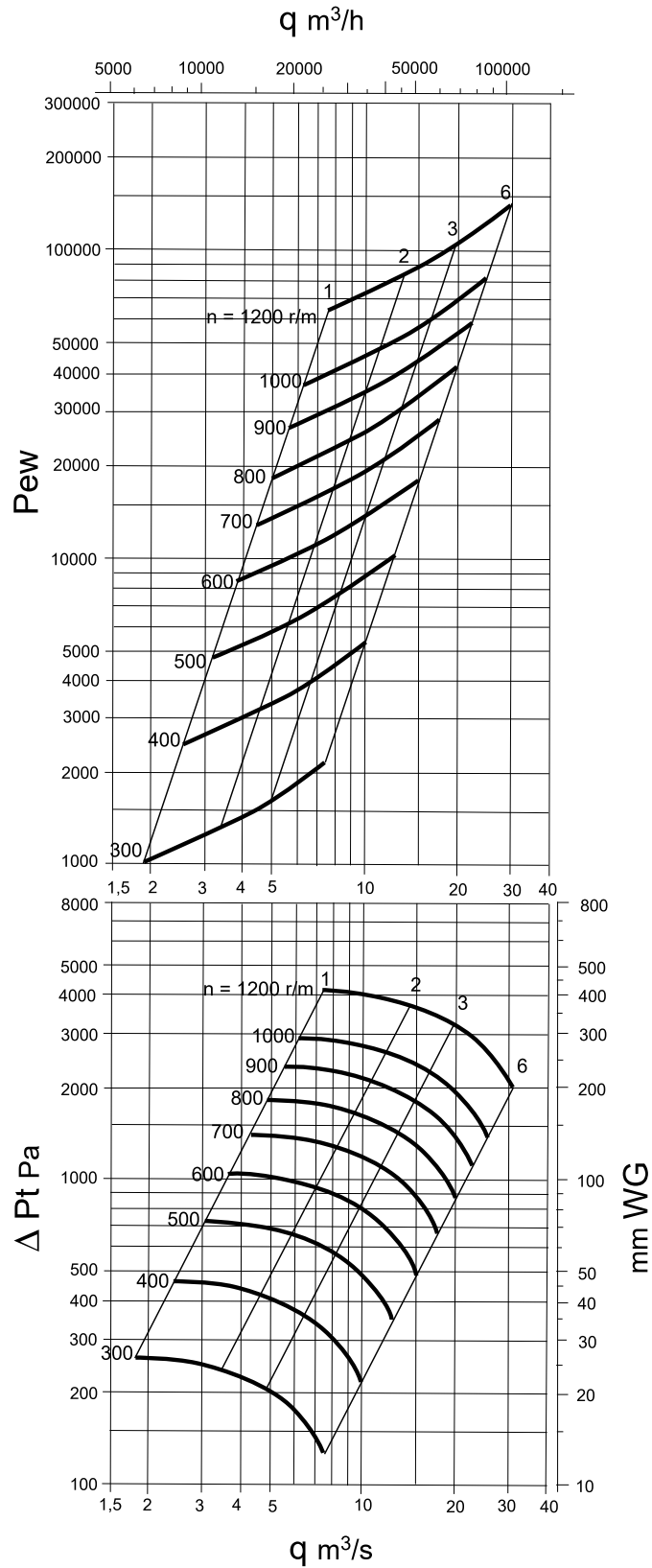

LCPB

Accessories

A wide range of accessories are available for LCPB fans, as shown in the exploded diagrams and specifications below.

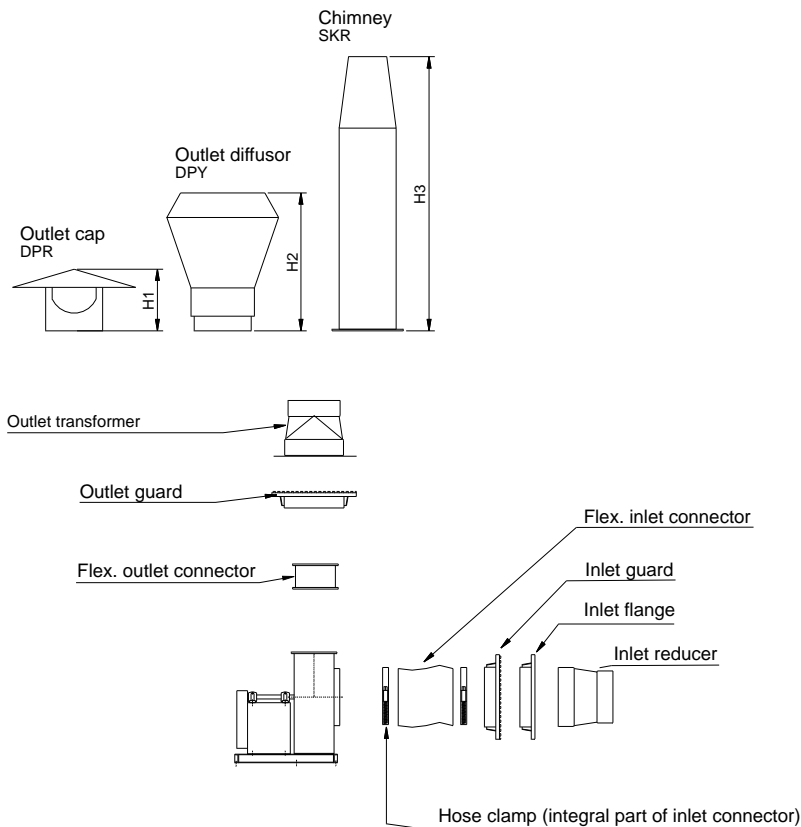

Specifications

- Drive Motor, according to fan capacity
- PVC weather protection for motor
- Vibration absorption set
- Complementary belt drive with belts, pulleys, bushing and belt guard
- Other Drainage stud at lowest point
- Splinter protector
- Inspection door

LCPB	DPR	DPY	SKR (Requires bracing)
	H1	H2	H3
040	210	650	2000
045	235	740	2000
050	265	740	2200
056	297	925	2500
063	330	925	2500
071	370	1110	2500
080	-	-	3000
090	-	-	4000
100	-	-	4000
112	-	-	4000

In an order or program text, a complete fan specification might read as follows:
 1 radial fan LCPB 056-10-2-0-1. Motor 3.0/0.6 kW 1445/975 rpm, 400 V, 50 Hz, 3-phase. Belt drive rotation speed 1200 rpm. Inlet connector. Outlet transformer. Outlet diffuser DPY. All inlet and outlet components made of PVC.

Note. Accessories manufactured in same material as fan casing.



INSTALLATION AND MAINTENANCE

Plastic centrifugal fans

<i>List of content</i>	<i>Page</i>
1. GENERAL	2
1.1 TRANSPORT AND LIFTING	2
1.2 DELIVERY CHECK	2
1.3 STORAGE BEFORE INSTALLATION	2
2. INSTALLATION	2
2.1 FITTING AND SECURING THE FAN	2
2.2 CONNECTION OF DUCTING	2
2.3 GUARDS	3
2.4 ELECTRIC INSTALLATION	3
3. TESTING	3
4. FAN OPERATION	4
5. MAINTENANCE	4
5.1 GENERAL INSPECTION	4
5.2 MOTOR	5
5.3 BELT DRIVE (if applicable)	5
5.4 BEARINGS (if applicable)	5
6. DISMANTLING THE IMPELLER	5

AB AREX

Postal address
Box 173
S-615 24 VALDEMARSVIK
SWEDEN

Visiting Address
Vammar Industriområde
VALDEMARSVIK
SWEDEN

Telephone
Int.: + 46 123 299 90
E-mail
mail@arex.se

Fax
Int.: + 46 123 513 18
Website
www.arex.se
Inst. & maint. centrifugal fans



INSTALLATION AND MAINTENANCE

1. GENERAL

The radial fans are either direct or belt driven to suit the intended application. The impeller is statically and dynamically balanced.

WARNING! Do not start working on the fan unless the power switch or the lockable main power switch has been switched in the OFF position.

1.1 TRANSPORT AND LIFTING

All handling should be carried out carefully.

Do not fix lifting equipment to plastic components or fan shaft. Lifting equipment should be affixed to a frame or steel foundation.

1.2 DELIVERY CHECK

Check carefully for signs of transport damage and make sure that the impeller rotates easily. In the event of damage to the equipment **make an immediate report to the carriers concerned**. Failure to report damage will result in the invalidity of the transportation insurance.

1.3 STORAGE BEFORE INSTALLATION

The fan shall be storage in a dry and heated up area, to avoid any risk of getting condensates inside the electric motor that could cause corrosion as a result.

2. INSTALLATION

2.1 FITTING AND SECURING THE FAN

The fan should be bolted (with or without the anti-vibration mountings) to a stable flat surface.

2.2 CONNECTION OF DUCTING

The fan casing should not support the weight of any ducting connected to the fan. Flexible duct sleeves should be used as ducting joints.

AB AREX

Postal address
Box 173
S-615 24 VALDEMARSVIK
SWEDEN

Visiting Address
Vammar Industriområde
VALDEMARSVIK
SWEDEN

Telephone
Int.: + 46 123 299 90
E-mail
mail@arex.se

Fax
Int.: + 46 123 513 18
Website
www.arex.se
Inst. & maint. centrifugal fans



INSTALLATION AND MAINTENANCE

2.3 GUARDS

Industrial safety legislation in most countries specifies that rotating machine components must be provided with reliable guards.

Such instructions must be observed when installing the fan. **If the inlet or outlet of the fan is open it must be provided with a protective grill, which is available as an accessory.**

2.4 ELECTRIC INSTALLATION

(To be carried out by an authorised electrician)

After connecting the fan motor, check that the impeller rotates in the direction shown by the arrow on the end wall of the casing.

The fan should be equipped with a safety-isolating switch (not included in the fan delivery). Before work is started on the fan, the safety-isolating switch must always be in position OFF.

3. TESTING

Before testing the fan check that:

1. The fan and motor have been correctly aligned and bolted down.
2. The belt or belts have been correctly tensioned, where applicable see point 5.3.
3. The bearings have been lubricated, where applicable see point 5.4
4. The anti-vibration mountings have been correctly fitted.
5. The flexible duct joints are tight and the fan casing does not support the weight of ducts.
6. Guards have been fitted and are well secured.
7. No tools or other foreign objects have been left in the casing or ducts.

Start the fan and check that:

1. The fan rotates in the correct direction.
2. There are no abnormal vibrations or noise.
3. The bearing temperatures are normal, where applicable see point 5.4.
4. The belt tension is correct after 24 hours operation, adjust if necessary.

When starting the fan after installing a new or renovated an existing bearing the bearing temperature may rise to a level which is 10-15°C higher then when the fan runs steadily. This condition is normal due to the fact that the bearing has been lubricated. The temperature will return to normal on steady fan operation after about 24 hours running time depending on the amount of grease that are filled in the bearing housing. (An excessive amount of grease is a common cause of high temperature). The above condition may also occur after periodically lubricating the bearing. The temperature generally increases as described above but will generally stabilise after the fan has run for 24 hours.

AB AREX

Postal address
Box 173
S-615 24 VALDEMARSVIK
SWEDEN

Visiting Address
Vammar Industriområde
VALDEMARSVIK
SWEDEN

Telephone
Int.: + 46 123 299 90
E-mail
mail@arex.se

Fax
Int.: + 46 123 513 18
Website
www.arex.se
Inst. & maint. centrifugal fans



INSTALLATION AND MAINTENANCE

4. FAN OPERATION

The fan should not be exposed to impact or shocks. Make sure no particles adhere to impeller as this can result in imbalance and a breakdown. If particles can be drawn into the fan inlet must be fitted with a grille, which is available as an accessory. The transported air's temperature must not exceed the values stated below:

Fan material	Maximum temp. °C
PVC	+55 °C
PP	+60 °C
PEH	+70 °C
GRP	+90 °C

(GRP quality withstanding higher temperatures can be supplied on request)

5. MAINTENANCE

5.1 GENERAL INSPECTION

Rotating machine components such as: bearings, motors and belt assemble are subjects to wear. Increased temperatures, high degrees of contamination and high speed increase the level of wear. In some installations ducts, which results in erosion damage to the impeller and fan casing, can occur. In other installations the dust can form a layer of grime on the impeller and fan casing. Layers of grime reduce the fan's output and give rise to imbalance resulting in breakdown.

After 1000 hours running time or when necessary:

1. Check that the impeller rotates easily and that it does not come into contact with the casing.
2. Check that fan does not vibrate or is noisy.
3. Check that the bearing temperature is normal. Noise from bearing can be an indication that lubrication is required.
4. Check all belts and their tension.
5. If necessary clean the fan casing and impeller.

Twice a year or when necessary:

1. Lubricate the bearings
2. Check that the impeller is undamaged and sits securely.
3. Check that the motor's fixture is in good condition and that bolts are tightened.
4. Clean all dirt, dust and oil from motor.

AB AREX

Postal address
Box 173
S-615 24 VALDEMARSVIK
SWEDEN

Visiting Address
Vammar Industriområde
VALDEMARSVIK
SWEDEN

Telephone
Int.: + 46 123 299 90
E-mail
mail@arex.se

Fax
Int.: + 46 123 513 18
Website
www.arex.se
Inst. & maint. centrifugal fans



INSTALLATION AND MAINTENANCE

5.2 MOTOR

Follow the manufacturer's instruction regarding lubrication and maintenance.

5.3 BELT DRIVE (if applicable)

Control the belt tension by pressing down the free belt length using the force F. The correct belt tension while applying pressure is equal to 1-1.5% of free belt length. The force F is defined in the table below.

Minimum pulley dia.	F (Newton) Minimum	F (Newton) Maximum
63 – 89	11	16
90 – 114	12	18
115 – 152	13	20

5.4 BEARINGS (if applicable)

Fans driven by V-belts are fitted with two bearings, which are lubricated using grease. The bearings should at least be lubricated 2 times/year, see appendix 1. Increased temperature conditions as well as other loads reduce the time interval between lubrication. Every increase of 15 °C over the 70 °C bearing temperature results in halving of the lubrication interval. The maximum permitted temperature of the grease must not be exceeded. The bearing housing is not usually fitted with a grease nipple. Grease is applied by removing the inner section of the bearing. All old grease should be removed before apply the new grease. The bearing housing should not be fitted completely with grease. Too much grease can cause extreme increase in temperature. After lubrication make sure the bearing runs easily without noise.

6. DISMANTLING THE IMPELLER

1. Remove the rear plate from the fan casing. (If the case is not fitted with a rear plate remove the inlet plate)
2. Dismantle the fan housing.
3. If belt driven, remove the bearing's clamping sleeve from the shaft.
4. Pull out the impeller and shaft.
5. Pull of the impeller from the shaft.

To assemble follow the above instructions in the reverse order.

AB AREX

Postal address
Box 173
S-615 24 VALDEMARSVIK
SWEDEN

Visiting Address
Vammar Industriområde
VALDEMARSVIK
SWEDEN

Telephone
Int.: + 46 123 299 90
E-mail
mail@arex.se

Fax
Int.: + 46 123 513 18
Website
www.arex.se
Inst. & maint. centrifugal fans



EG-Försäkran om överensstämmelse



TILLVERKARE:

**AB AREX
Box 173
615 24 VALDEMARSVIK**

MASKIN:

**Radialfläktar med beteckningar:
LCPA MCBP HCTP
LCPB MCPP
LCPR MCTP
LCPS**

FÖRSÄKRAN:

**Försäkrar under eget ansvar att angiven maskin
är tillverkad enligt följande direktiv och standarder.
Maskindirektivet 98/37/EEG
Lågspänningsdirektivet 73/23/EEG inkl. tillägg
EMC-direktivet 89/336/EEG inkl. tillägg**

ÅBEROPAD STANDARD:

**SS EN 60 034-1
SS EN 292-1-2
SS EN 294**

FÖRBEHÅLL:

**Denna försäkran gäller under förutsättning att fläkten
installeras enl. våra anvisningar.
Se installation och skötselanvisningar.**

**Valdemarsvik 2003
AB AREX**

A handwritten signature in blue ink, appearing to be a stylized name or initials.