

MIETZSCH

GmbH Lufttechnik Dresden

USER INFORMATION

ROOF FANS

SERIES VRV
vertical outlet



Roof fans made of plastic materials

Series VRV with vertical outlet

Usable in ventilation engineering of all branches of industry

High chemical resistivity by encapsulated motors and use of plastic materials

Low noise emission

Volumetric flow up to 10,500 m³/h

Pressure increase up to 1200 Pa

Capacity gradation by six sizes

Explosion-proof versions according to European Directive 2014/34/EU (ATEX)



Installation accessories such as roof bases, noise absorption bases etc.

Wide range of electrical accessories

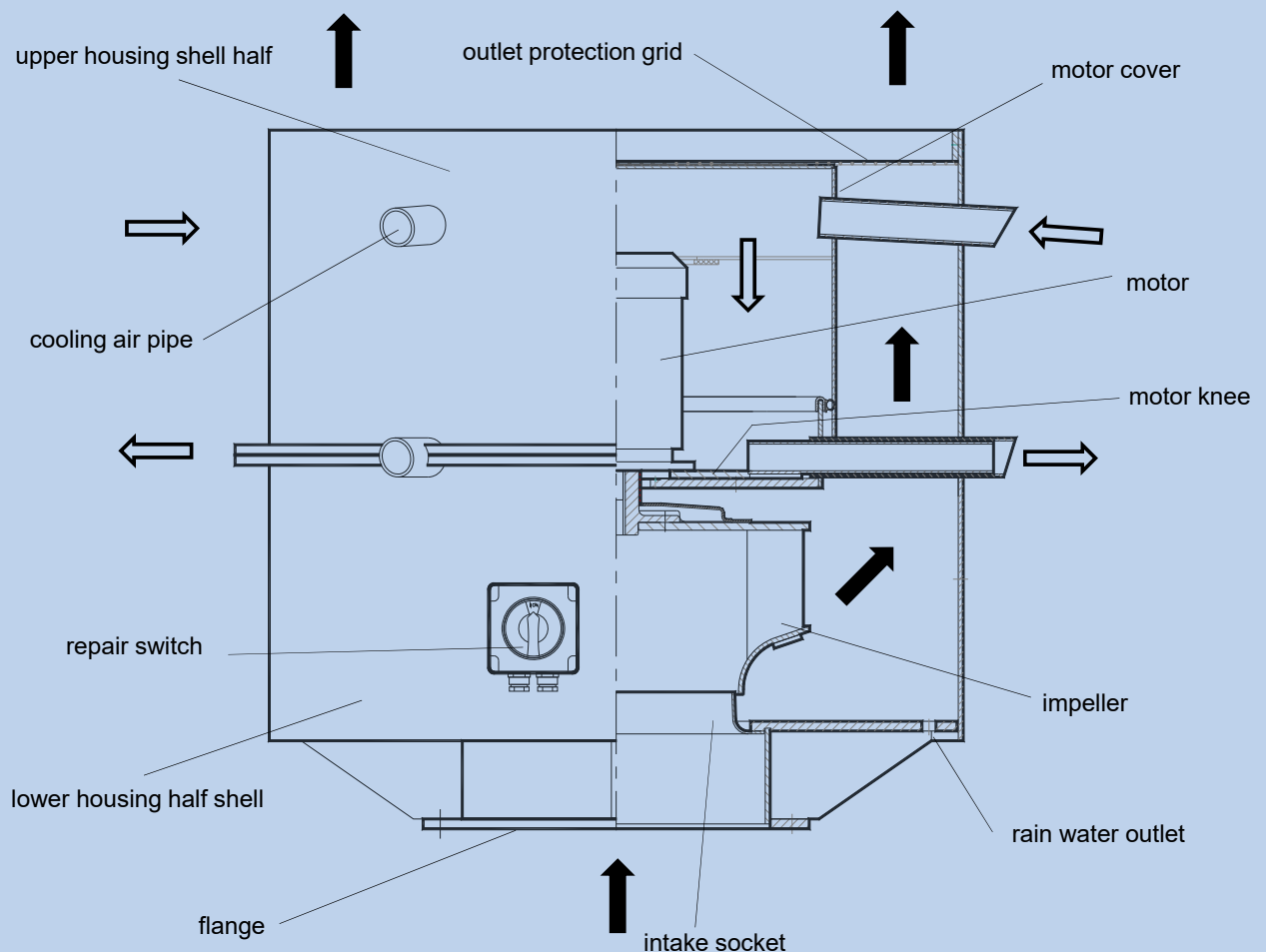

Data specified herein are subject to alteration without prior notice.
They will not be valid without written confirmation by the manufacturers.

APPLICATION

Good corrosion resistance makes the type VRV Roof fans with vertical outlet suitable preferably for process exhaust systems in the chemical and pharmaceutical industries, for ventilation of laboratories, battery rooms, pickling plants, laundries, galvanic and agricultural units etc.

The medium to be conveyed is taken in axially and blown out vertically with high speed. This allows good mixing with the environment.



Roof fan VRV with sound absorbing base SDS

TECHNICAL DESCRIPTION

The fans are made in five nominal sizes with four different housing sizes. Plastic covers protect steel components against corrosion. High efficiency is accomplished and noises of flow are minimized because of the optimized design of the housing parts.

The **impellers**, made of PPs and PPsX, curved backward are balanced dynamically according to ISO 1940.

The **housing** is split horizontally to facilitate maintenance and cleaning of the fan and the pipeline connected. It can be made of PPs, PE and PPsX.

The driving **motor** is encapsulated completely so that contact with the medium conveyed is ruled out. Cooling air is fed in separately from outside.

The fan is connected to pipelines or the matched accessories by a stable flange (dimensions according to MIETZSCH factory standard MWS 53030).

CONDITIONS OF USE

permissible ambient temperature -30 ... +40 °C

permissible temperature of volume flow -30 ... +50 °C

Higher temperatures depend on the design size, material, and speed rate and are subject to consultation with the manufacturers.

The applied materials have good **chemical resistance** against many substances. It should be considered, however, that even plastic materials are attacked by certain chemicals. This depends on the following items:

Chemical composition and concentration of medium conveyed

Temperature and time of action

Mechanical loading and residual stress resulting from processing

Many applications in fields such as laboratories and stockrooms for chemicals, in agriculture and damp-loaded processes led to good results with "standard materials" such as PPs or PE that can be used without any problem in most cases. Critical applications may occur in the process-technological industry - surface refinement, pickling plants, process exhaust air in microelectronics.

For selection of suitable materials the purpose of use of the fan and the type of medium conveyed should be specified in requests or orders.

Slightly **dust-laden** media can also be conveyed but lead to increased wear.

Working range The fan always operates in stable regime and can be applied even outside the characteristic range specified.

Permissible inclination of fan axis (slope of roof) $\pm 10^\circ$

SPECIAL DESIGNS and ACCESSORIES (further information at the end of prospect)

Splinter guard, assembly plate, assembly plate with non-return flap, sound-absorbing base, base for corrugated roofs,

Ventilation components: ducts, elbows, flaps, air hoods, pipe and profiled silencers

Electric accessories: repair switch, motor protection switch, pole changer, complete fan controls, frequency inverter (also with pressure and volume flow control), air flow monitoring



EXPLOSION PROTECTION

Guideline 2014/34/EU (**ATEX**) newly regulates explosion protection for non-electrical devices from March 29, 2014. In addition to observation of design and safety instructions according to DIN EN 13463 and VDMA 24 169, the fan has to be assigned exactly to the relevant degree of protection and labelled accordingly. The manufacturers have to prove conformity.

Areas with hazard of explosion exist in the chemical industry, in gasworks, coking plants, varnishing units, petrol stations, sewage and wastewater treatment plants, laboratory systems etc.

Prerequisites of explosion are:

- Flammable substances (such as gas, dust),
- Oxygen in sufficient quantity of air
- Ignition source (sparks, fire, hot surfaces, electrostatic discharges)

The following measures have to be taken if explosions cannot be excluded:

- Prevention of explosible atmosphere
- Avoidance of ignition sources
- Moderation of damaging effects of explosions

An efficient and supervised ventilation system is often a sufficient measure for avoiding ignitable atmosphere and, consequently, hazard of explosion.

The Protection demanded on a fan depends on the probability of occurrence of explosive atmosphere in the medium conveyed or/and in the surrounding. Hazard is classified in three zones:

Explosions hazard	Hazard zone	Avoidance of ignition sources	Category acc. to ATEX
continuous long periods	zone 0	even in the event of rare incidents	1
likely to occur	zone 1	even in the event of frequent disturbances/faults	2
infrequently short period	zone 2	during normal operation	3

The plant operator or the relevant board of control has to decide which protection is necessary and which additional regulations have to be considered. This means that the customer has to specify in the order which kind of protection the fan has to have.

Fans VRV are supplied for the following types of ignition protection:

Zone 1: II 2G c IIB+H2 T3

Zone 2: II 3G c IIB+H2 T3

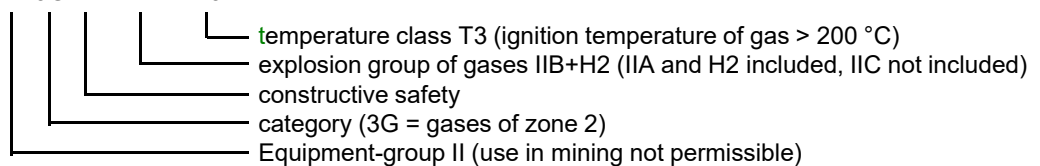

On principle, application in zone 0 is not possible. Gases of explosion group IIC (hydrogen excluded), gases with ignition temperature below 200 °C, and combustible dusts are likewise impermissible.

Classification generally differentiates between inside (medium conveyed) and outside (surrounding). Every zone of hazard requires its special design. Explosion-proof electrical devices (motors, switches etc.) and electrically conductive materials (preferably conductive and flame retardant polypropylene --> PPsX) are employed. General classification is as follows:

Hazard zone		MIETZSCH designation	Motor		Impeller/housing material
inside	outside		without converter	with converter	
zone 1	zone 1	Z1Z1	EEx e II	EEx de	conductive
zone 2	zone 2	Z2Z2	EEx e II	EEx de	not conductive
zone 2	none	Z2Z3	EEx e II	standard	not conductive

Special demands for operation with frequency inverter

Motors with increased safety EEx e II must not be used in inverter operation. Flameproof enclosed Motors EEx de can be employed in inverter mode if they are equipped with winding protection (design TS). Standard motors can be used and operated in inverter mode if the surrounding is not an EX zone and the fan meets certain design demands.

EXPLANATION OF TYPE DESIGNATIONS

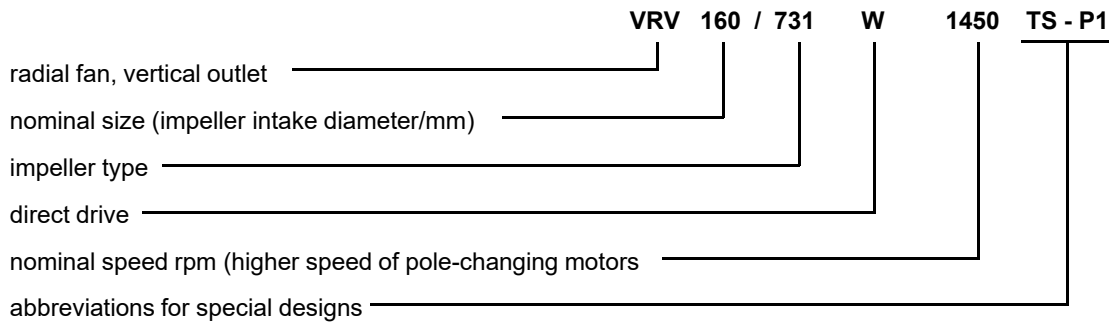

- E = single-phase drive
- TS = with thermal winding protection (PTC resistor)
- P1 = speed halving (Dahlander) such as 1450 P1 = 1,450/710 rpm
- P2 = changeover to next smaller speed such as 1450 P2 = 1,450/950 rpm
- EX = with explosion-proof motor
- ZiZo = explosion-proof fan for zone i=inside and o=outside
such as Z1Z2 = inside zone 1 and outside zone 2
- DD = delta motor connection for inverter regime with 3 x 230 V

PERFORMANCE PARAMETERS

All performance parameters are determined on MIETZSCH-own test racks. The design corresponds to DIN 24 163. The **volumetric flow** is determined from the differential pressure by means of a measuring nozzle according to EN ISO 5167 .

For roof fans destined to be arranged at the end of a plant and freely blowing out into the environment, the **pressure difference for free blowout Δp_{fa}** is used as follows

$$\Delta p_{fa} = p_{bar} - p_{ges\ S} = p_{bar} - p_{statS} - \rho/2 * c_S^2 = \Delta p_{stat} - \rho/2 * c_S^2$$

This size corresponds to the usable total pressure increase on the suction side (S) and follows the pressure losses at the pressure side (D).

Duct sound power level L_{WA}

The measuring method for determination of the duct sound power level is specified in DIN 45 635, Part 9. Interpretation is according to

$$L_{WA} = L_{value\ measuredt} + 10 * \log (\pi / 4 * D^2) \text{ dB} \quad D = \text{diameter of measuring line}$$

Sound power level L_{3m}

Several measuring points are arranged on an enveloping surface around the fan. Conversion to the specified level at 3 meters is calculated from

$$L_{3m} = L_{value\ measuredt} + 20 * \log (r_m / 3m) \text{ dB}$$

PERFORMANCE

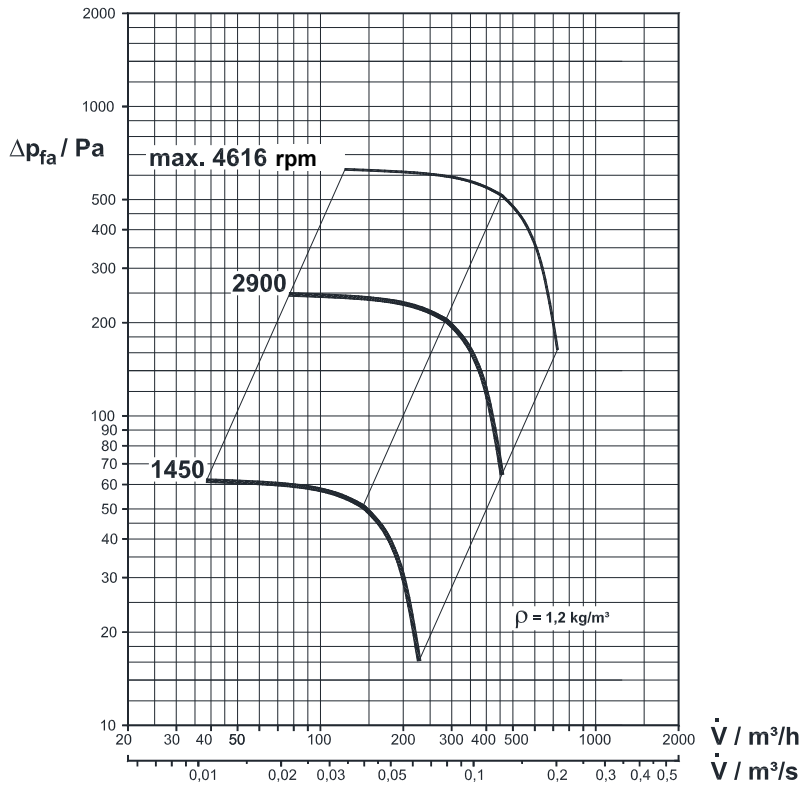

Design features

- Impeller with vanes curved backward
- Welded plastic housing
- Various fastening versions by flange
- Drive motor encapsulated completely
- Repair switch with auxiliary contact fastened on fan

Performance sizes

According to DIN 24 163, roof fans are specified by their pressure difference for free blowout:

$$\Delta p_{fa} = p_{bar} - p_{ges s} = p_{bar} - p_{stat} - r/2 * c_s^2$$

In the desired working point, this pressure difference must be greater than the intake side pressure loss.

PRINCIPAL DIMENSIONS

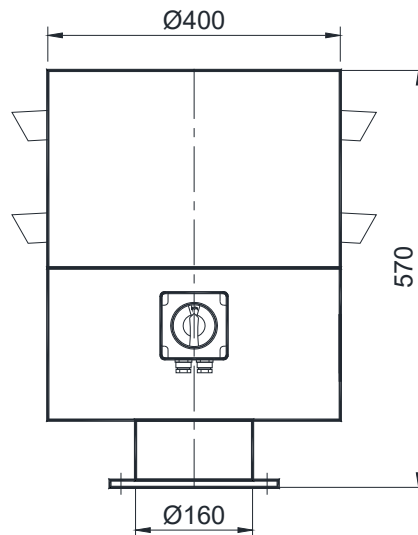
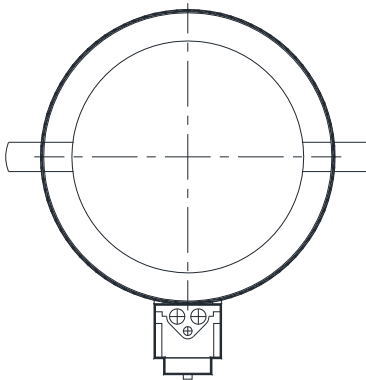

Flange dimensions

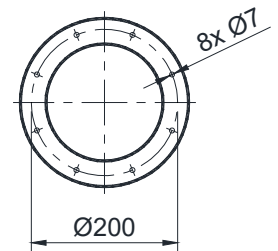

MOTOR VERSIONS for standard motor 3~400V/50Hz

(other motors, such as single-phase, pole-changing or Ex, upon inquiry)

fan type	speed rpm	power requirement kW	nom. motor power kW	nom. motor current A	weight with motor kg	L_{A3m} dB(A)	L_{WA} dB(A)	octave-band L_{WA-Okf} / dB(A)							
								63	125	250	500	1000	2000	4000	8000
VRV 100/731 W 1450	1,450	0.004	0.12	0.43	11.0	43	61	41	52	56	55	54	47	38	24
VRV 100/731 W 2900	2900	0.035	0.18	0.51	11.0	50	67	44	53	61	63	60	57	48	37
VRV 100/731 W 2900	4616 ¹⁾	0.115	0.18	0.51	11.0	59	77	51	62	67	73	72	66	61	51

¹⁾ - in operation with frequency inverter > 50 Hz

L_{A3m} = A - weighted sound pressure level at distance of 3 m

L_{WA} = A - weighted sound power level in duct

PERFORMANCE

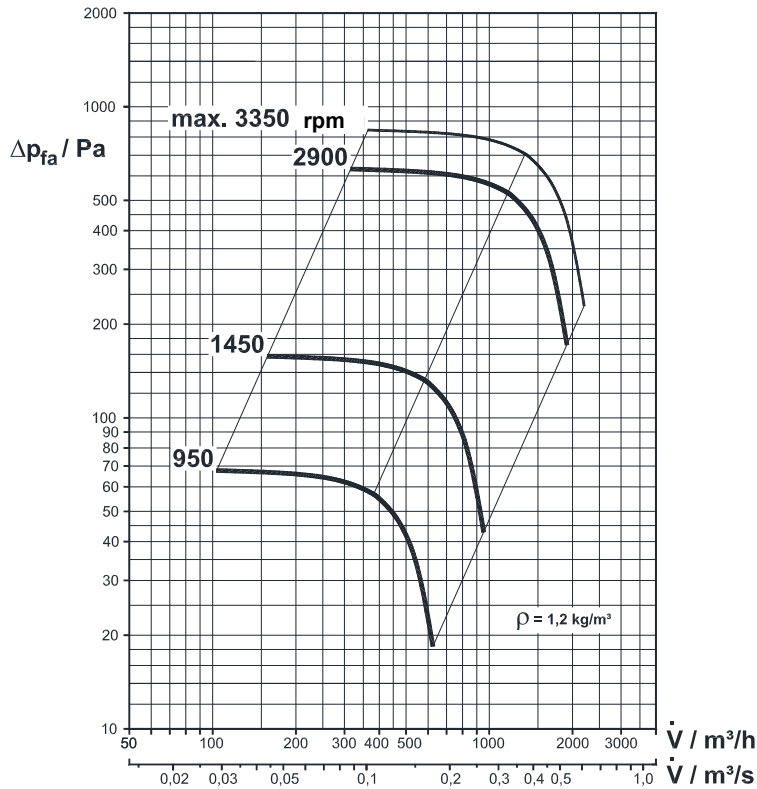

Design features

- Impeller with vanes curved backward
- Welded plastic housing
- Various fastening versions by flange
- Drive motor encapsulated completely
- Repair switch with auxiliary contact fastened on fan

Performance sizes

According to DIN 24 163, roof fans are specified by their pressure difference for free blowout:

$$\Delta p_{fa} = p_{bar} - p_{ges\ s} = p_{bar} - p_{statS} - r/2 * c_s^2$$

In the desired working point, this pressure difference must be greater than the intake side pressure loss.

PRINCIPAL DIMENSIONS

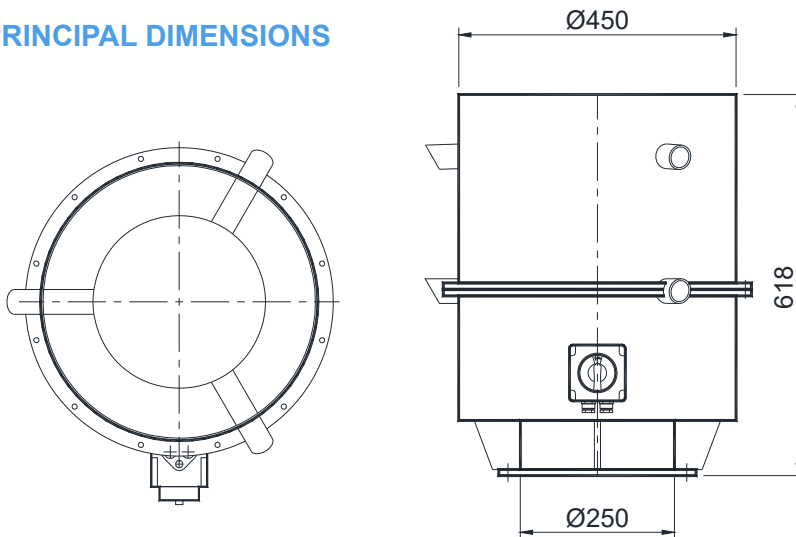

Flange dimensions

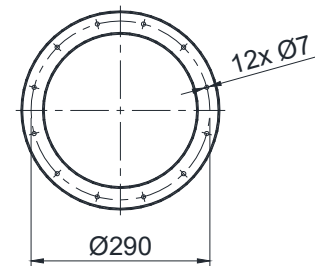

MOTOR VERSIONS for standard motor 3~400V/50Hz

(other motors, such as single-phase, pole-changing or Ex, upon inquiry)

fan type	speed rpm	power requirement kW	nom. motor power kW	nom. motor current A	weight with motor kg	L _{A3m} dB(A)	L _{WA} dB(A)	octave-band L _{WA-Okt} / dB(A)							
								63	125	250	500	1000	2000	4000	8000
VRV 160/731 W 950	950	0.011	0.09	0.39	18.0	39	56	38	49	49	52	48	41	31	18
VRV 160/731 W 1450	1,450	0.038	0.12	0.43	17.0	44	62	45	49	58	55	55	49	40	27
VRV 160/731 W 2900	2,900	0.293	0.37	0.99	19.0	59	77	57	66	68	74	69	67	60	49
VRV 160/731 W 2900	3,350 ¹⁾	0.528	0.55	1.36	20.0	63	80	59	69	71	77	73	71	64	53

¹⁾ - in operation with frequency inverter > 50 Hz

L_{A3m} = A - weighted sound pressure level at distance of 3 m

L_{WA} = A - weighted sound power level in duct

PERFORMANCE

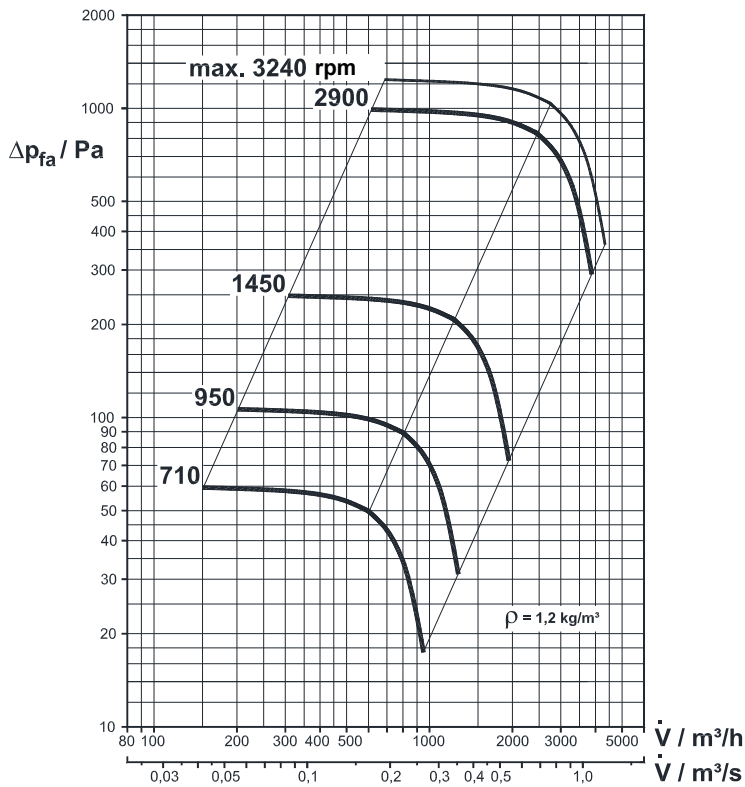

Design features

- Impeller with vanes curved backward
- Welded plastic housing
- Various fastening versions by flange
- Drive motor encapsulated completely
- Repair switch with auxiliary contact fastened on fan

Performance sizes

According to DIN 24 163, roof fans are specified by their pressure difference for free blowout:

$$\Delta p_{fa} = p_{bar} - p_{ges} = p_{bar} - p_{stats} - r/2 * c_s^2$$

In the desired working point, this pressure difference must be greater than the intake side pressure loss.

PRINCIPAL DIMENSIONS

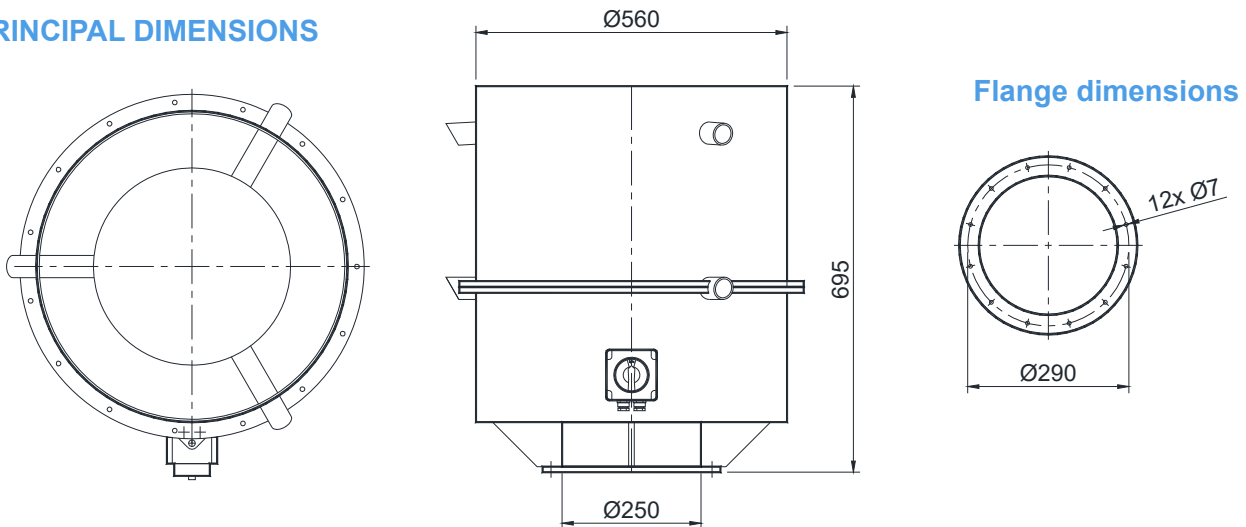

MOTOR VERSIONS for standard motor 3~400V/50Hz

(other motors, such as single-phase, pole-changing or Ex, upon inquiry)

fan type	speed rpm	power requirement kW	nom. motor power kW	nom. motor current A	weight with motor kg	L _{A3m} dB(A)	L _{WA} dB(A)	octave-band L _{WA-Okt} / dB(A)							
								63	125	250	500	1000	2000	4000	8000
VRV 200/731 W 710	710	0.014	0.09	0.38	26.0	37	55	40	47	50	48	48	43	37	28
VRV 200/731 W 950	950	0.034	0.18	0.67	25.0	43	60	45	53	55	53	53	49	42	34
VRV 200/731 W 1450	1,450	0.118	0.25	0.75	25.0	49	66	53	57	61	61	57	55	49	41
VRV 200/731 W 2900	2,900	0.954	1.10	2.25	33.0	64	82	64	74	74	77	75	69	65	57
VRV 200/731 W 2900	3,240 ¹⁾	1.320	1.50	3.05	36.0	67	84	66	76	77	79	78	72	68	60

¹⁾ - in operation with frequency inverter > 50 Hz

L_{A3m} = A - weighted sound pressure level at distance of 3 m

L_{WA} = A - weighted sound power level in duct

PERFORMANCE

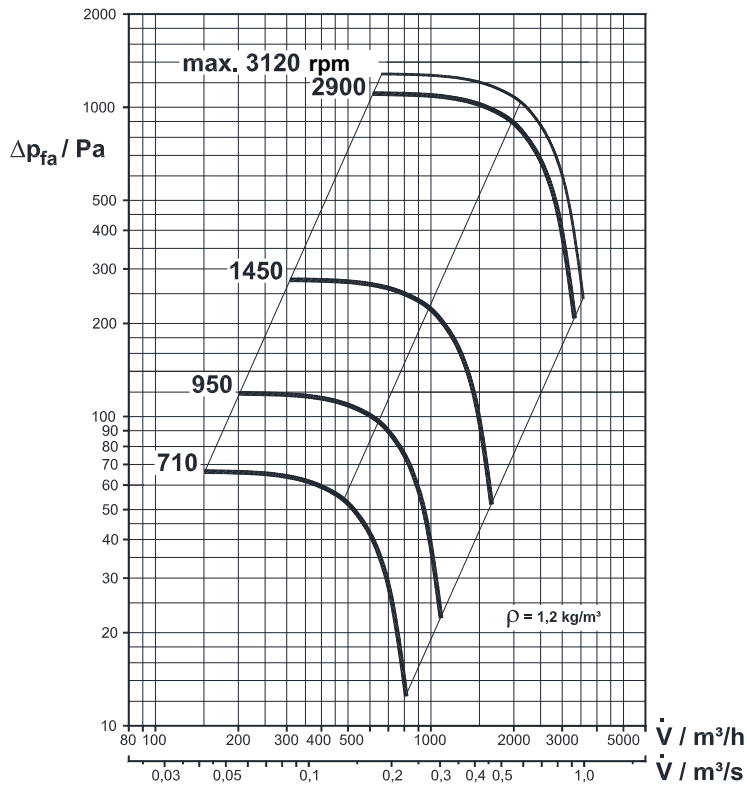

Design features

- Impeller of PP, glass fibre-reinforced, with vanes curved backward
- Welded plastic housing
- Various fastening versions by flange
- Drive motor encapsulated completely
- Repair switch with auxiliary contact fastened on fan

Performance sizes

According to DIN 24 163, roof fans are specified by their pressure difference for free blowout:

$$\Delta p_{fa} = p_{bar} - p_{ges\ S} = p_{bar} - p_{stat\ S} - r/2 * c_s^2$$

In the desired working point, this pressure difference must be greater than the intake side pressure loss.

PRINCIPAL DIMENSIONS

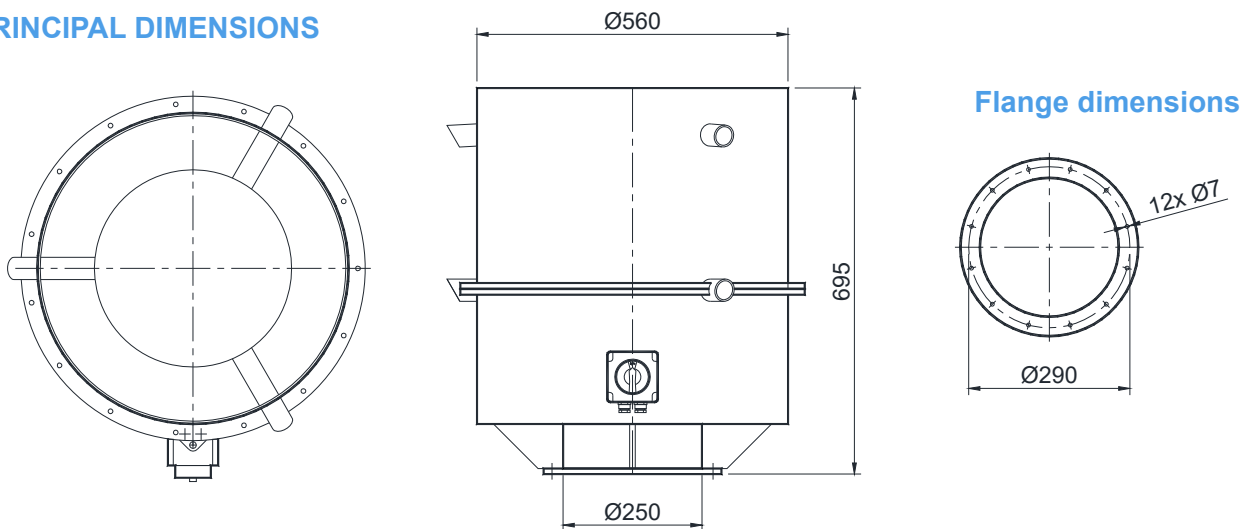

MOTOR VERSIONS for standard motor 3~400V/50Hz

(other motors, such as single-phase, pole-changing or Ex, upon inquiry)

fan type	speed rpm	power requirement kW	nom. motor power kW	nom. motor current A	weight with motor kg	L _{A3m} dB(A)	L _{WA} dB(A)	octave-band L _{WA-Okt} / dB(A)							
								63	125	250	500	1000	2000	4000	8000
VRV 200/732 W 710	710	0.010	0.09	0.38	26.0	35	52	33	45	49	45	43	37	28	16
VRV 200/732 W 950	950	0.023	0.18	0.67	25.0	40	58	37	50	54	51	49	43	35	24
VRV 200/732 W 1450	1,450	0.087	0.25	0.75	25.0	46	64	40	49	59	60	55	50	43	32
VRV 200/732 W 2900	2,900	0.698	0.75	1.71	31.0	61	79	52	62	68	75	75	68	61	52
VRV 200/732 W 2900	3,120 ¹⁾	0.858	1.10	2.25	33.0	63	81	53	63	70	77	77	69	63	54

¹⁾ - in operation with frequency inverter > 50 Hz

L_{A3m} = A - weighted sound pressure level at distance of 3 m

L_{WA} = A - weighted sound power level in duct

PERFORMANCE

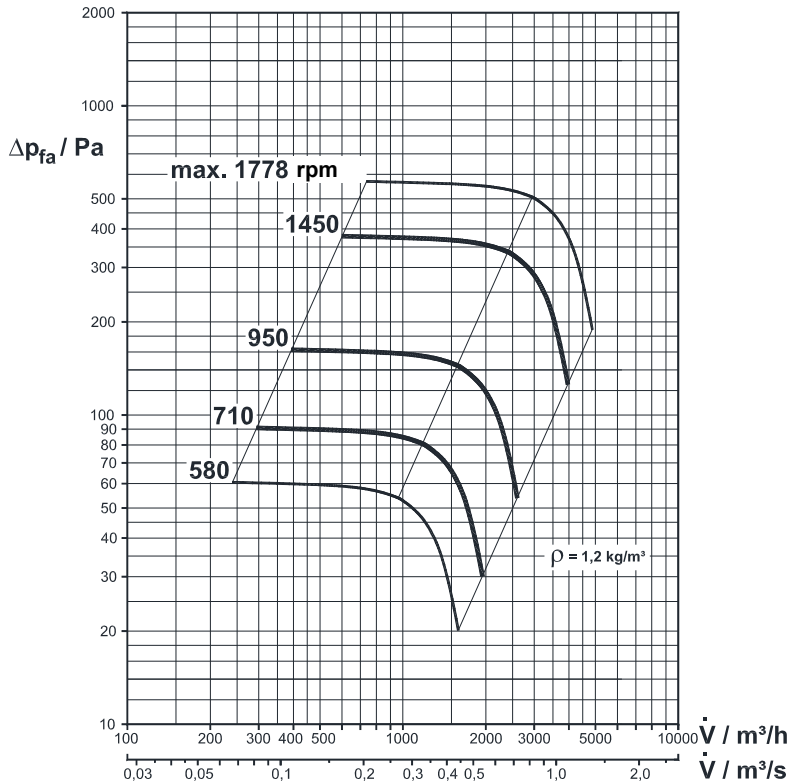

Design features

- Impeller with vanes curved backward
- Welded plastic housing
- Various fastening versions by flange
- Drive motor encapsulated completely
- Repair switch with auxiliary contact fastened on fan

Performance sizes

According to DIN 24 163, roof fans are specified by their pressure difference for free blowout:

$$\Delta p_{fa} = p_{bar} - p_{ges s} = p_{bar} - p_{stats} - r/2 * c_s^2$$

In the desired working point, this pressure difference must be greater than the intake side pressure loss.

PRINCIPAL DIMENSIONS

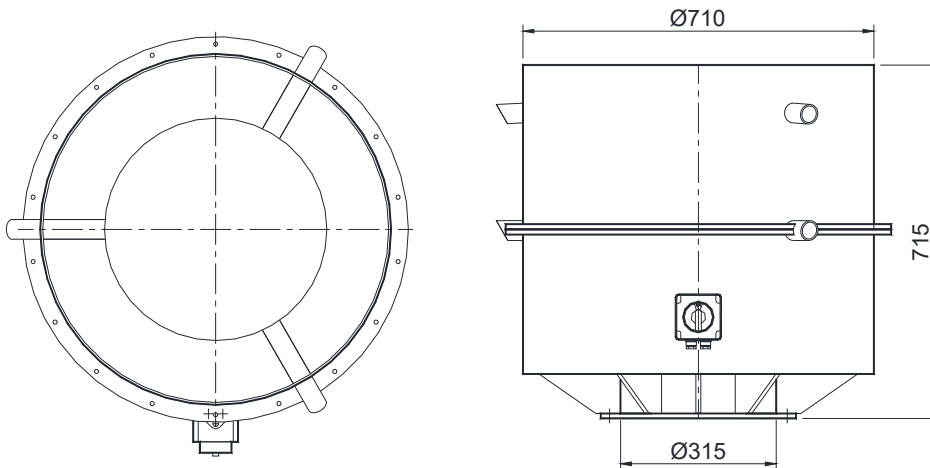

Flange dimensions

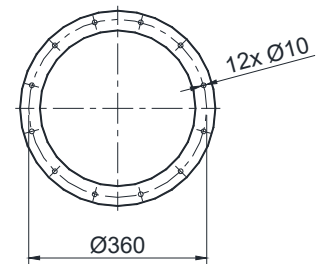

MOTOR VERSIONS for standard motor 3~400V/50Hz

(other motors, such as single-phase, pole-changing or Ex, upon inquiry)

fan type	speed rpm	power requirement kW	nom. motor power kW	nom. motor current A	weight with motor kg	L _{A3m} dB(A)	L _{WA} dB(A)	octave-band L _{WA-Okt} / dB(A)							
								63	125	250	500	1000	2000	4000	8000
VRV 250/731 W 580	580 ¹⁾	0.023	0.09	0.38	37.0	39	56	41	49	51	51	46	43	36	26
VRV 250/731 W 710	710	0.042	0.09	0.38	37.0	42	59	44	52	54	54	50	47	40	30
VRV 250/731 W 950	950	0.102	0.18	0.67	36.0	47	64	48	56	59	59	54	51	44	35
VRV 250/731 W 1450	1450	0.358	0.37	0.96	38.0	55	72	59	62	67	68	65	58	54	45
VRV 250/731 W 1450	1778 ²⁾	0.670	0.75	1.81	56.0	59	77	62	66	71	72	70	63	59	50

¹⁾ - in operation with frequency inverter < 50 Hz

²⁾ - in operation with frequency inverter > 50 Hz

L_{A3m} = A - weighted sound pressure level at distance of 3 m

L_{WA} = A - weighted sound power level in duct

PERFORMANCE

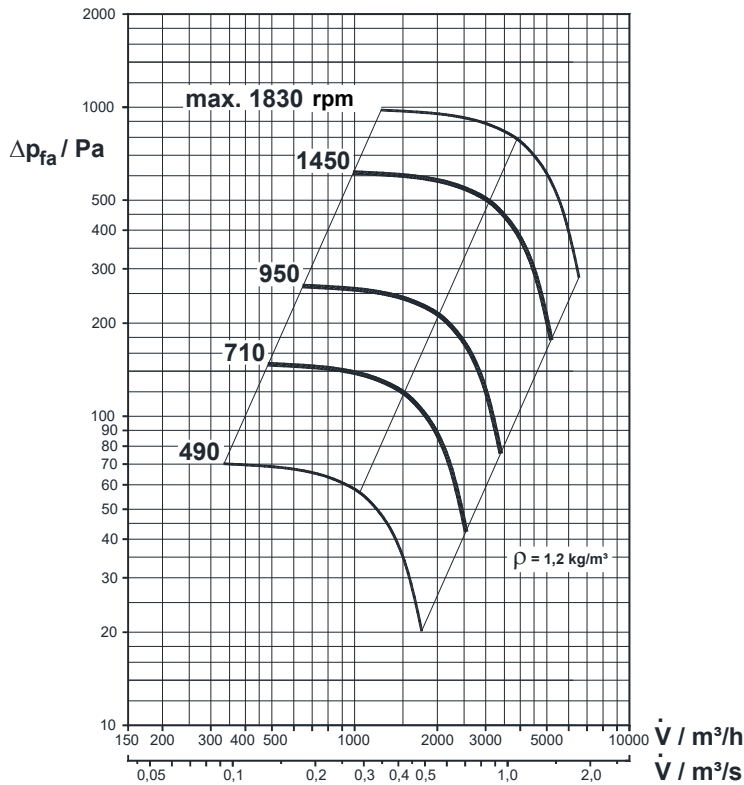

Design features

- Impeller with vanes curved backward
- Welded plastic housing
- Various fastening versions by flange
- Drive motor encapsulated completely
- Repair switch with auxiliary contact fastened on fan

Performance sizes

According to DIN 24 163, roof fans are specified by their pressure difference for free blowout:

$$\Delta p_{fa} = p_{bar} - p_{ges\ s} = p_{bar} - p_{stats} - r/2 * c_s^2$$

In the desired working point, this pressure difference must be greater than the intake side pressure loss.

PRINCIPAL DIMENSIONS

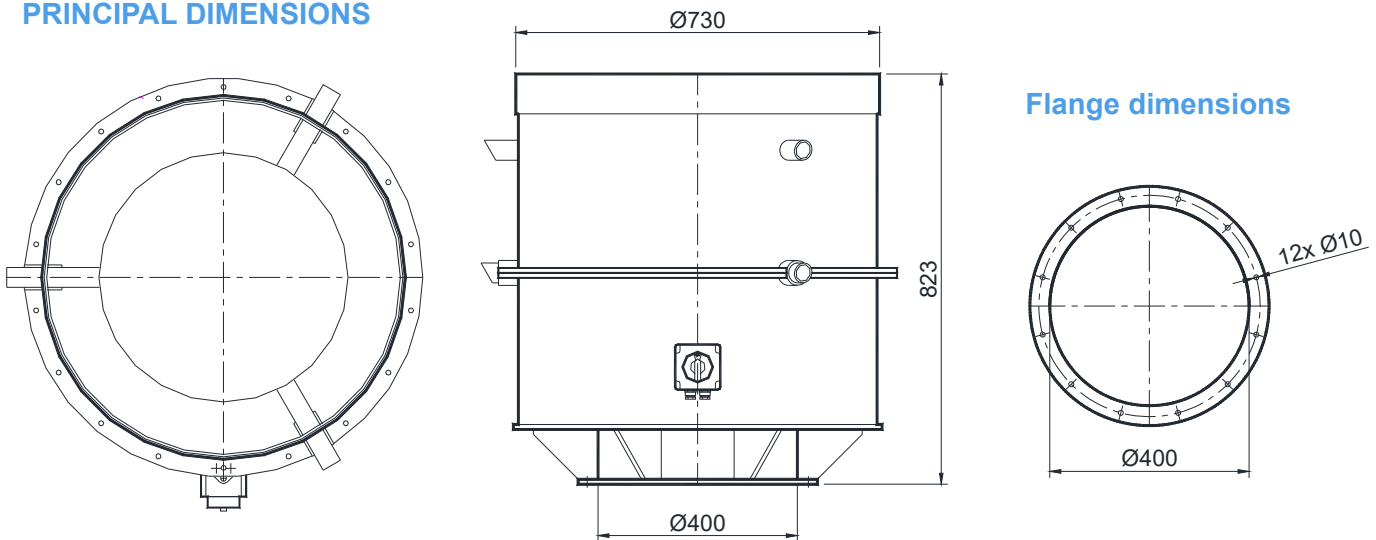

MOTOR VERSIONS for standard motor 3~400V/50Hz

(other motors, such as single-phase, pole-changing or Ex, upon inquiry)

fan type	speed rpm	power requirement kW	nom. motor power kW	nom. motor current A	weight with motor kg	L _{A3m} dB(A)	L _{WA} dB(A)	octave-band L _{WA-Okt} / dB(A)							
								63	125	250	500	1000	2000	4000	8000
VRV 315/712 W 490	490 ¹⁾	0.028	0.18	0.78	39.0	44	61	48	52	53	57	55	51	45	37
VRV 315/712 W 710	710	0.085	0.18	0.78	39.0	48	65	48	57	59	58	59	55	49	41
VRV 315/712 W 950	950	0.203	0.37	1.16	39.0	51	68	51	60	62	61	62	59	53	45
VRV 315/712 W 1450	1.450	0.722	0.75	1.75	45.0	61	78	59	67	73	73	70	69	63	56
VRV 315/712 W 1450	1.830 ²⁾	1.450	1.50	3.15	50.0	66	83	64	72	78	78	75	74	69	61

¹⁾ - in operation with frequency inverter < 50 Hz

²⁾ - in operation with frequency inverter > 50 Hz

L_{A3m} = A - weighted sound pressure level at distance of 3 m

L_{WA} = A - weighted sound power level in duct

PERFORMANCE

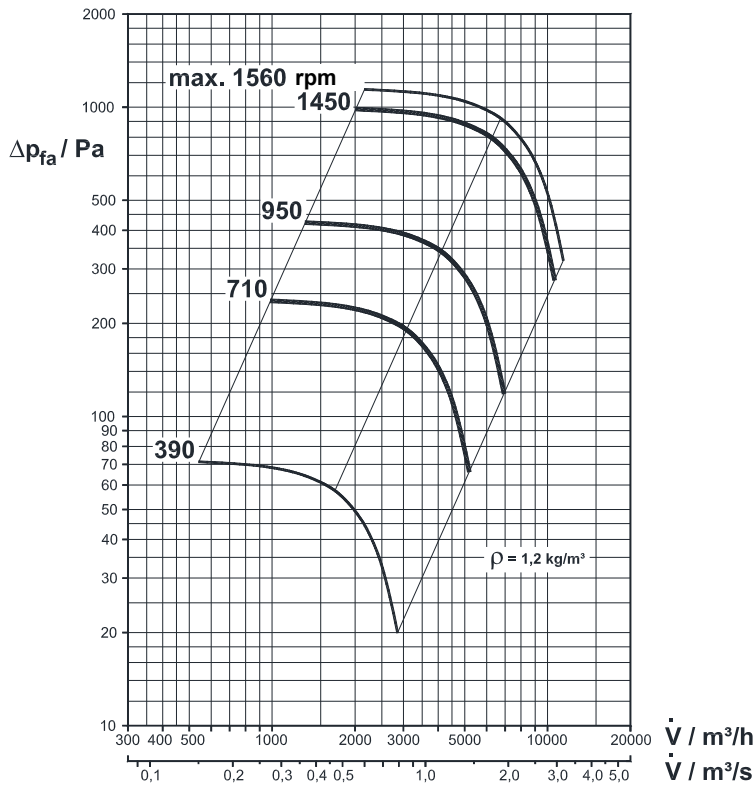

Design features

- Impeller with vanes curved backward
- Welded plastic housing
- Various fastening versions by flange
- Drive motor encapsulated completely
- Repair switch with auxiliary contact fastened on fan

Performance sizes

According to DIN 24 163, roof fans are specified by their pressure difference for free blowout:

$$\Delta p_{fa} = p_{bar} - p_{ges s} = p_{bar} - p_{stats} - r/2 * c_s^2$$

In the desired working point, this pressure difference must be greater than the intake side pressure loss.

PRINCIPAL DIMENSIONS

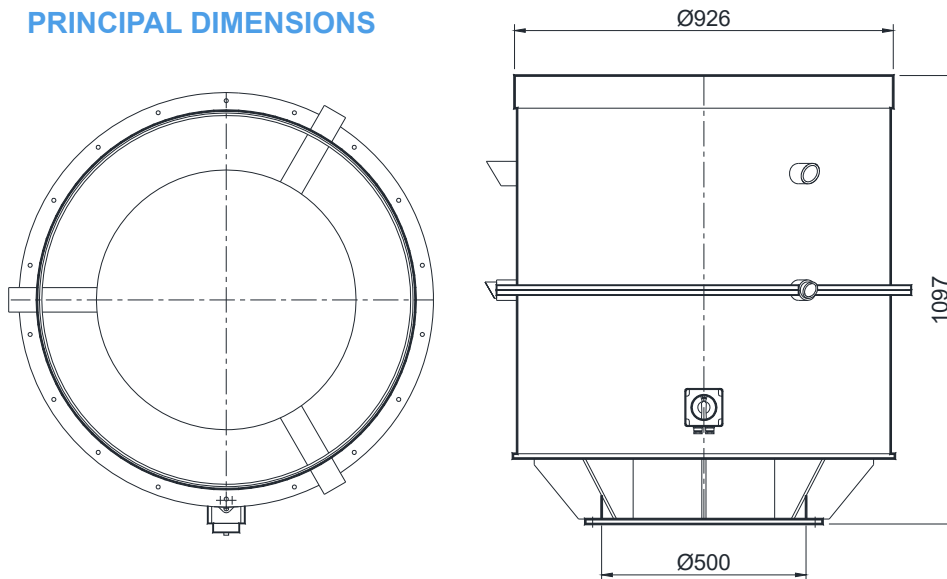

Flange dimensions

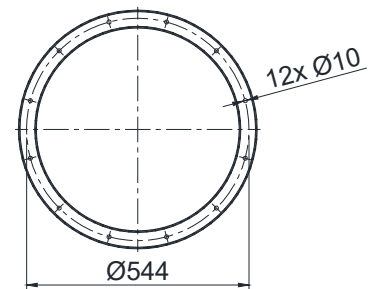

MOTOR VERSIONS for standard motor 3~400V/50Hz

(other motors, such as single-phase, pole-changing or Ex, upon inquiry)

fan type	speed rpm	power requirement kW	nom. motor power kW	nom. motor current A	weight with motor kg	L _{A3m} dB(A)	L _{WA} dB(A)	octave-band L _{WA-Ok1} / dB(A)							
								63	125	250	500	1000	2000	4000	8000
VRV 400/711 W 390	390 ¹⁾	0.059	0.55	1.63	83.0	43	60	45	49	53	54	56	50	46	40
VRV 400/711 W 710	710	0.357	0.55	1.63	83.0	55	72	56	64	65	67	66	66	58	52
VRV 400/711 W 950	950	0.855	1.50	3.45	101.0	62	79	63	70	72	73	72	73	65	59
VRV 400/711 W 1450	1,450	3.040	5.50	10.50	135.0	68	86	69	75	80	80	79	76	75	66
VRV 400/711 W 1450	1,560 ²⁾	3.780	5.50	10.50	135.0	70	88	71	77	82	82	81	78	77	68

¹⁾ - in operation with frequency inverter < 50 Hz

²⁾ - in operation with frequency inverter > 50 Hz

L_{A3m} = A - weighted sound pressure level at distance of 3 m

L_{WA} = A - weighted sound power level in duct

PERFORMANCE

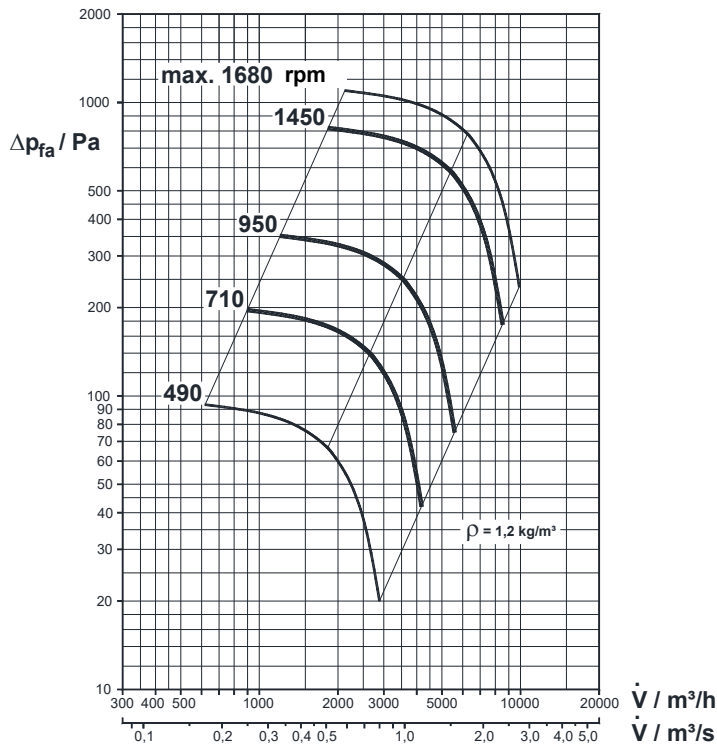

Design features

- Impeller with vanes curved backward
- Welded plastic housing
- Various fastening versions by flange
- Drive motor encapsulated completely
- Repair switch with auxiliary contact fastened on fan

Performance sizes

According to DIN 24 163, roof fans are specified by their pressure difference for free blowout:

$$\Delta p_{fa} = p_{bar} - p_{ges s} = p_{bar} - p_{stats} - r/2 * c_s^2$$

In the desired working point, this pressure difference must be greater than the intake side pressure loss.

PRINCIPAL DIMENSIONS

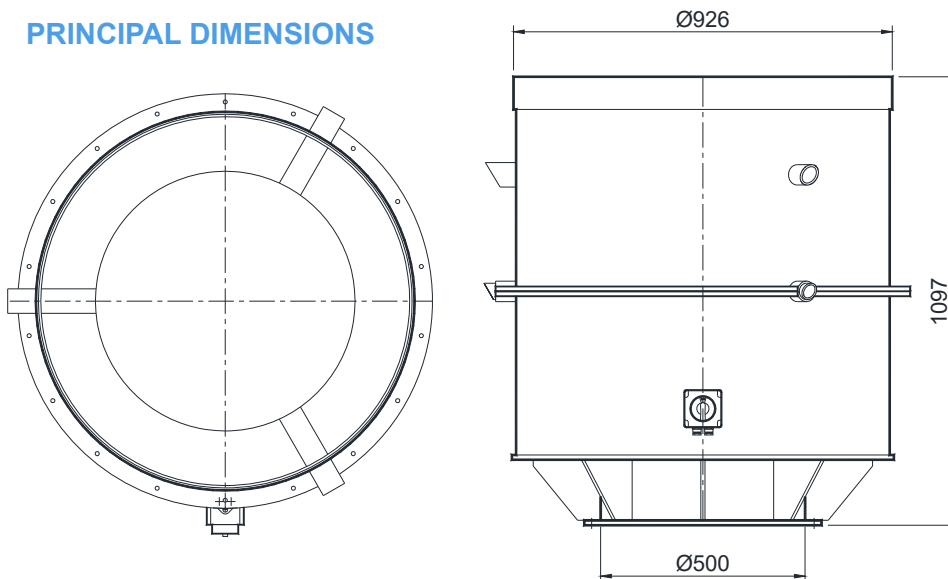

Flange dimensions

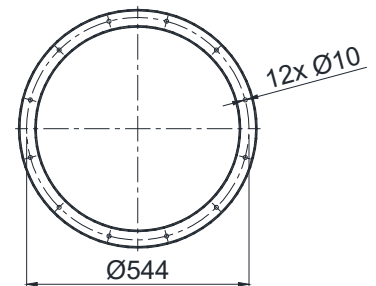

MOTOR VERSIONS for standard motor 3~400V/50Hz

(other motors, such as single-phase, pole-changing or Ex, upon inquiry)

fan type	speed rpm	power requirement kW	nom. motor power kW	nom. motor current A	weight with motor kg	L _{A3m} dB(A)	L _{WA} dB(A)	octave-band L _{WA-Ok} / dB(A)							
								63	125	250	500	1000	2000	4000	8000
VRV 400/751 W 490	490 ¹⁾	0.100	0.37	1.17	87.0	48	65	50	54	58	59	61	55	51	45
VRV 400/751 W 710	710	0.282	0.37	1.17	87.0	52	70	53	61	62	64	63	63	55	49
VRV 400/751 W 950	950	0.674	0.75	1.96	92.0	59	76	60	67	69	70	69	70	62	56
VRV 400/751 W 1450	1450	2.400	3.00	5.90	106.0	65	83	66	72	77	77	76	73	72	63
VRV 400/751 W 1450	1680 ²⁾	3.730	5.50	10.50	140.0	69	87	70	76	81	81	80	77	75	66

¹⁾ - in operation with frequency inverter < 50 Hz

²⁾ - in operation with frequency inverter > 50 Hz

L_{A3m} = A - weighted sound pressure level at distance of 3 m

L_{WA} = A - weighted sound power level in duct

Assembly plate MPL - VRV

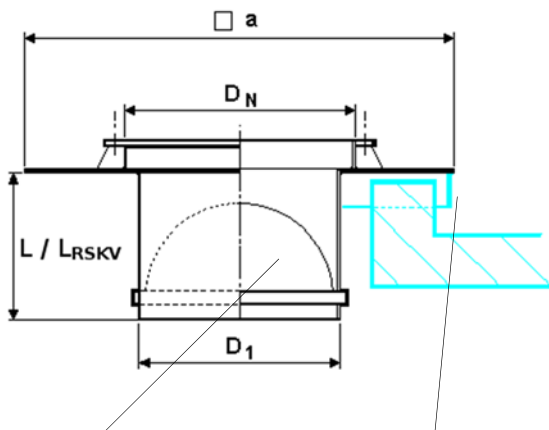

optional with non-return flap RSKV

optional with rain water edge RKA

The assembly plate MPL-VRV is used for fastening the VRV Roof fans on flat roofs and foundations. The flange with nominal diameter D_N is employed for fan fastening. Fastening elements and a seal are in the range of delivery. Diameter D_1 on the connection side is smooth. The plate should be supported on its entire face. Careful sealing toward the roof is important.

Special designs: with non-return flap RSKV
with rain water edge RKA
base height $H = 300$ mm
pipe connection (with welded socket)
design for pitched roof

Special dimensions and variants for particular roof designs and foundations upon inquiry.

Material: accord. to housing material Designation: **MPL - VRV $D_N - D_1$**

fan type	type of assembly plate	D_N mm	D_1 mm	a mm	H mm	L mm	L_{RSKV} mm
VRV 100/731	MPL-VRV 160 - 160	160	160	500	60	300	97
	MPL-VRV 160 - 110	160	110	500	60	300	125
VRV 160/731	MPL-VRV 250 - 250	250	250	560	60	300	157
	MPL-VRV 250 - 160	250	160	560	60	300	145
VRV 200/731 ../732	MPL-VRV 250 - 250	250	250	560	60	300	157
	MPL-VRV 250 - 200	250	200	560	60	300	175
VRV 250/731	MPL-VRV 315 - 315	315	315	800	60	500	206
	MPL-VRV 315 - 250	315	250	800	60	500	200
VRV 315/712	MPL-VRV 400 - 400	400	400	800	60	500	266
	MPL-VRV 400 - 315	400	315	800	60	500	250
VRV 400/711	MPL-VRV 500 - 500	500	500	900	60	500	309
	MPL-VRV 500 - 400	500	400	900	60	500	308

Sound-absorbing base SDS - VRV

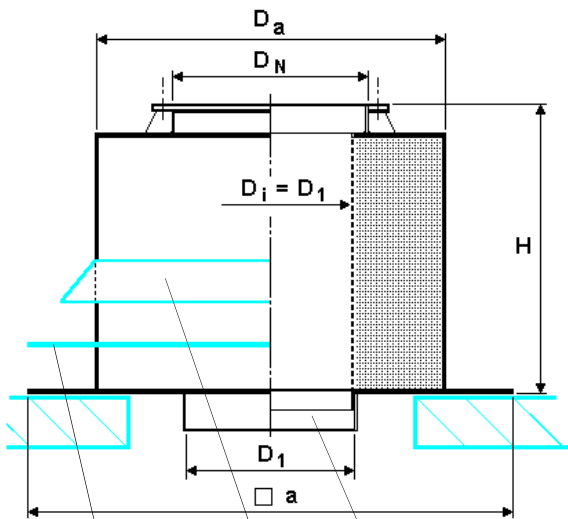

optional with sealing plate DPL (for roof insulation)

optional with rain collar RKR (for roof insulation)

socket (welded on)

The sound-absorbing base is used for damping the sound power in the suction line. The absorber material is incombustible according to DIN 4102 and covered with glass wool and perforated plates.

The flange with nominal diameter D_N is employed for fan fastening. Fastening elements and a seal are in the range of delivery. Connecting diameter D_1 is designed as a socket.

The base should be supported on its entire face. Careful sealing toward the roof is important.

Special designs: with non-return flap RSKV
with rain water edge RKA
with sealing plate DPL or rain water collar RKR
with cable bushing
design for pitched roof

Special dimensions and variants for particular roof designs and foundations upon inquiry.

Material: accord. to housing material Designation: **SDS - VRV $D_N - D_1$**

fan type	base type	D_N mm	D_1 mm	D_a mm	a mm	H mm	D_e (250Hz) dB
VRV 100/731	SDS-VRV 160 - 160	160	160	400	650	500	13
	SDS-VRV 160 - 110	160	110	400	650	500	27
VRV 160/731	SDS-VRV 250 - 250	250	250	500	750	500	10
	SDS-VRV 250 - 160	250	160	500	750	500	19
VRV 200/731 ../732	SDS-VRV 250 - 250	250	250	500	750	500	10
	SDS-VRV 250 - 200	250	200	500	750	500	14
VRV 250/731	SDS-VRV 315 - 315	315	315	560	810	1000	16
	SDS-VRV 315 - 250	315	250	560	810	1000	24
VRV 315/712	SDS-VRV 400 - 400	400	400	750	1000	1000	15
	SDS-VRV 400 - 315	400	315	750	1000	1000	19
VRV 400/711	SDS-VRV 500 - 500	500	500	850	1000	1000	12
	SDS-VRV 500 - 400	500	400	850	1000	1000	15

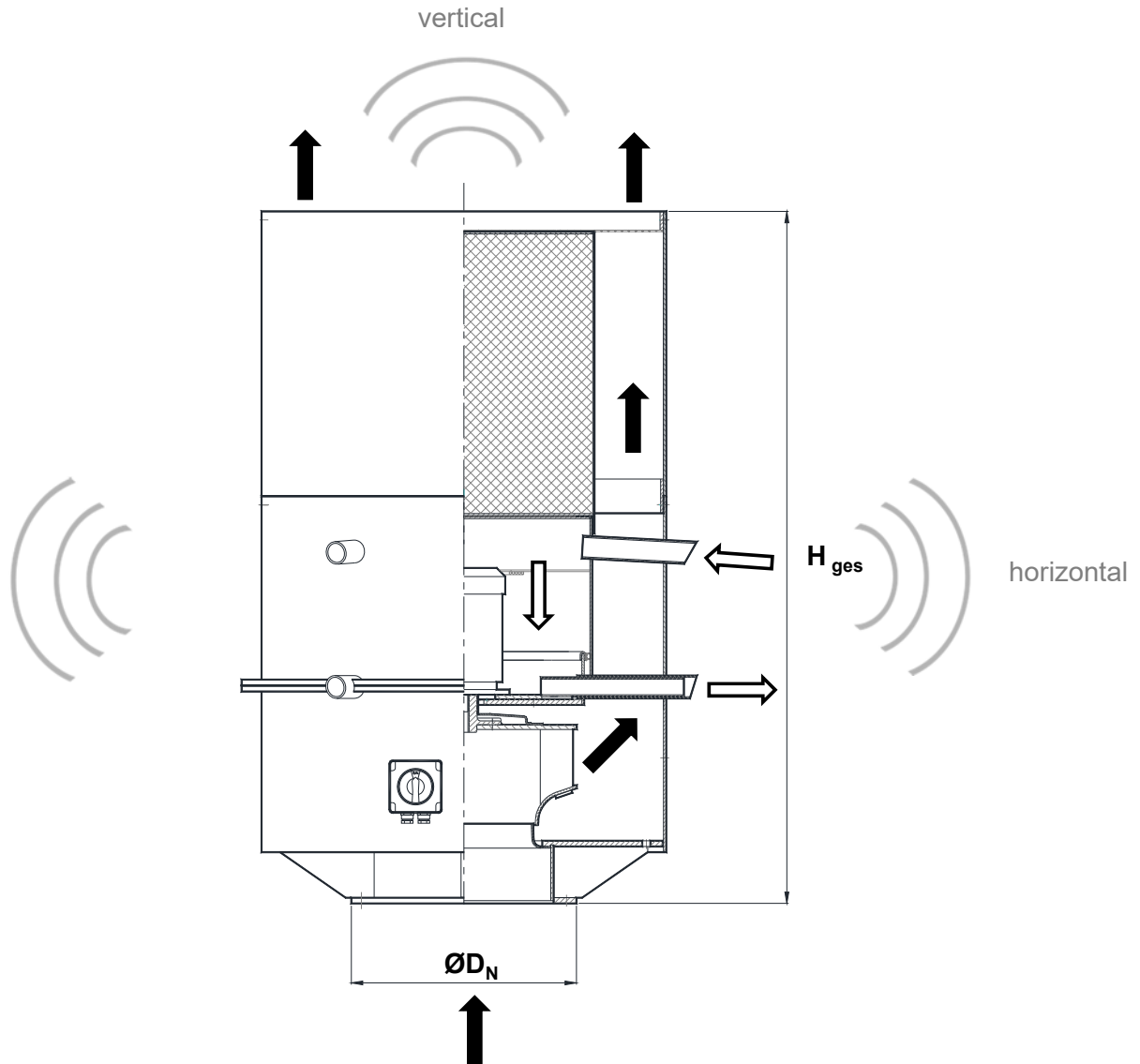

Dimensions / Noise absorption

The circular silencer welded on the upper housing half shell leads to extra noise absorption on the outlet side which better than the standard design.

fan type	D _N mm	H _{ges} mm	noise absorption D _e dB	
			horizontal	vertical
VRV 100/731 - ASD	160	1020	9	6
VRV 160/731 - ASD	250	1120	7	4
VRV 200/731 - ASD	250	1200	7	4
VRV 200/732 - ASD	250	1200	7	4
VRV 250/731 - ASD	315	1220	7	4
VRV 315/712 - ASD	400	1520	7	4
VRV 400/711 - ASD	500	1800	7	4

Material: according to housing material

Example how to order:

Roof fan VRV 160 and 1,450 rpm with outlet silencer:

VRV 160 / 731 W 1450 - ASD

Roof fan of plastic material - vertical outlet explosion-proof

Mietzsch Lufttechnik - series VRV

Permitted for EX-Categorie according to EU-guideline 2014/34/EU (ATEX) :



Location in relation to the fan	gas area 1	Category gas area 2	no EX-area
inside / outside	II 2G c IIB+H2 T3 <input type="radio"/>	II 3G c IIB+H2 T3 <input type="radio"/>	no <input type="radio"/>

Radial impeller with backward curved vanes optionally of PPs or electrically conductive plastic PPsX welded with balancing quality G 6.3 according to ISO 1940, fly-mounted on a shaft

balancing quality and vibration speed of the fans correspond to ISO 14694

split housing with vertical inlet and outlet, made of PPs (PE, PPsX), intake nozzle shaped aerodynamically

fastening with assembly plate MPL or sound-absorbing base SDS with flange

Direct drive with **EX-motor** outside the flow conveyed

Protection: EEXe II - increased safety
EEXde II - flameproof enclosure

Direct drive by **standard motor** (no EX-protection) outside the flow conveyed
Design in single-phase / three-phase / pole-changing

Motor protection: no / thermistor (TS)

repair switch fastened on fan : three-pole with auxiliary contact / EX-version
connection box outside in EX-version (for zone 1 / zone 2 outside)

Safety equipment according to VDMA 24 167

VRV _ _ _ / 7 _ _ W _ _ _ - _ _ - _ _ _ - _ _ - _ _ _

nominal size							
impeller type							
nominal speed							
special design							
material							

volumetric flow	: _____	m ³ /h
pressure increase	: _____	Pa
free outlet	: _____	
temperature of medium conveyed	: _____	°C
motor power	: _____	kW
voltage / frequency	: _____	V _____ Hz
nominal current	: _____	A
fan speed	: _____	rpm
noise level L _{A3m}	: _____	dB(A)
weight	: _____	kg

Medium conveyed / purpose:

Accessories and special equipment ¹⁾

- ◆ Assembly plate MPL – VRV / Assembly plate MPL-VRV with non-return flap
- ◆ Sound-absorbing base SDS - VRV
- ◆ Outlet silencer ASD
- ◆ Other elements

¹⁾ delete as applicable

Our program of products and services

Roof fans

of all-plastic design, horizontally or vertically blowing out with many assembly accessories

Radial fans

of thermoplastic material and FRP, direct and belt driven up to about 150 000 m³/h and 6 500 Pa

Special fans

duct fans, built-in devices, mobile radial fans, Venturi injectors

Explosion-proof fans

according to ATEX for zone 1 and zone 2

AIR technology systems and components

pipes, ducts, fittings, flaps, gas-tight shutoff flaps, exhaust air hoods, deflector hoods, suction hoods and many more of plastic material, complete air technology systems for industry and craft, air cleaning plants, laboratory and process exhaust systems

Central ventilation systems

in housing construction, special-purpose fans, exhaust elements, controlling and regulating devices

Noise protection

rectangular and cylindrical sound attenuators, silencing casings in corrosion-proof design

Exhaust gas cleaning

droplet eliminators and moisteners, gas scrubbers for separation of gaseous dangerous substances, dust filter

Heat exchangers

for heat recovery from moist and aggressive exhaust air

Tanks

of thermoplastic material for liquids endangering water, according to water resources regulations

Controlling and regulating elements and systems

switches, motor protection devices, speed controllers, frequency inverter, fan controls, flow supervision

Special designs

devices, linings, special components etc. of plastic material

Engineering performances

planning, calculation, and design, ventilation measurement on standardized test stands, low and high temperature test in company-own climatic test chambers

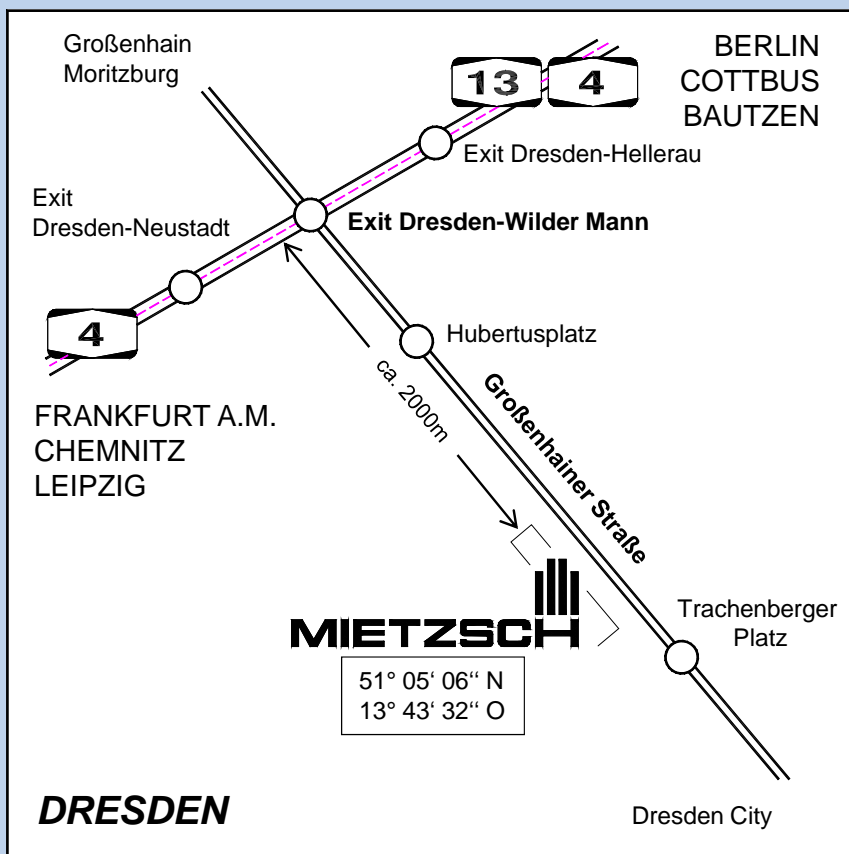

MIETZSCH

GmbH Lufttechnik Dresden

Großenhainer Straße 137
DE-01129 Dresden

Telefon: +49 351 8433 0
FAX: +49 351 8433 160
E-mail: mietzsch@mietzsch.de
Internet: <http://www.mietzsch.de>