

Flexit S30 R

Type	Automatic
S30 REL	SP400
S30 RER	SP400
S30 RWL	SP400
S30 RWR	SP400
S30 REL	CS1000
S30 RER	CS1000
S30 RWL	CS1000
S30 RWR	CS1000

Control Panel included in all units.



	S30 RW	S30 RE
Rated voltage:	400 V	400 V
Fuse:	3 x 16 A	3 x 32 A
Rated current, total:	8,8 A	30 A
Rated power, total:	3 350 W	18 350 W
Rated power, electric battery:		15 000 W
Rated power, fans:	2 x 1 400 W	2 x 1 400 W
Rated preheating power:		
Fan type:	B-wheel	B-wheel
Fan motor control:	Frequency converter	Frequency converter
Max. fan speed:	3 000 rpm	3 000 rpm
Filter type (SUP/EXTR):	F7	F7
Filter dimensions (W x H x D):	2 x (400 x 795 x 380 mm)	2 x (400 x 795 x 380 mm)
Number of bags:	8	8
Weight:	319 kg	319 kg
Duct connection:	250 x 600 mm	250 x 600 mm
Height:	1 680 mm	1 680 mm
Width:	1 690 mm	1 690 mm
Depth:	895 mm	895 mm

Flexit S30 R

Accessories



Bag Filter
Art.no. Type
12345 F7



Closing Air Damper w/Spring Return
Art.no. Type
14487 600x250 spring return
14486 600x250 on/off



3-way Valve
Art.no. Type
57228 KVS 2,5 3-way
56433 KVS 2,5 2-way
56072 fittings KVS 2,5
56233 KVS 4,0 3-way
56434 KVS 4,0 2-way



Motor 3-way Valve
Art.no.
56234



SP440 CO₂
Art.no.
09359



SP 435 Motion Detector
Art.no.
09358



SP 450 Motion Detector
Art.no.
09390



SP430 Motion Detector
Art.no.
09357



SP 445 Smoke Detector
Art.no.
09362

Accessories, automatic SP 400



SP 405 Week Timer
Art.no. 09297



SP 415 Forcing Switch
Art.no. 09299



SP 420 Heat Control Switch
Art.no. 09294



RM 400 Refrigeration Control
Art.no. 09356

Accessories, automatic CS1000



CC 1060 GSM-card
Art.no. 09370

Modem, antenna with cable and magnet holder, transformer and cable 0,8 m.

CC 1061 GSM-equipment
Art.no. 09371



CC 1062 LON-card
Art.no. 09372



CC 1063 WEB/OPC-card
Art.no. 09373



CC 1040 Room Sensor
Art.no. 09368



CC 1041 Outdoor Air Sensor
Art.no. 09369



CC 1050 Pressure Sensor
Art.no. 09367



Press Button
Art.no. 09364

Flexit S30 R

S30 RWR

System drawing, water-based heating

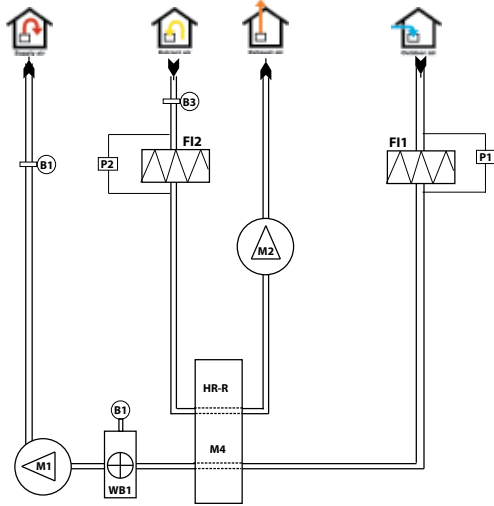

- | | | | |
|------|------------------------------------|-----|---|
| M1 | Supply air fan | B3 | Temperature sensor, extract air |
| M2 | Extract air fan | B4 | Temperature sensor, outdoor air |
| M4 | Motor, rotor | B5 | Temperature sensor, water battery (frost relay) |
| F1 | Supply air filter | DA1 | Air damper, exhaust air (not standard) |
| F2 | Extract air filter | DA2 | Air damper, outdoor air (not standard) |
| HR-R | Rotary wheel-type heat exchanger | WB1 | Water Battery |
| P1 | Pressure guard, supply air filter | | |
| P2 | Pressure guard, extract air filter | | |
| B1 | Temperature sensor, supply air | | |

S30 RER

System drawing, electric heating

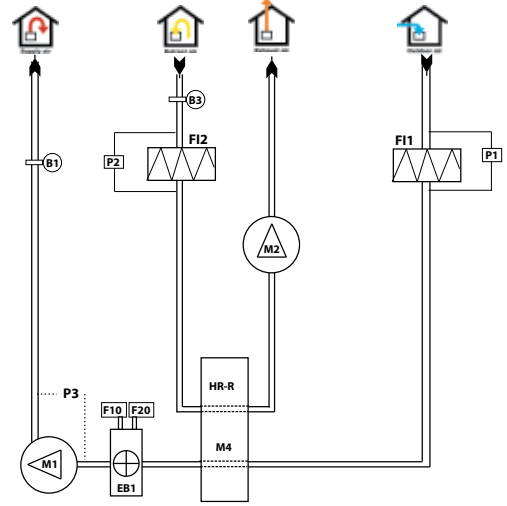

- | | | | |
|------|--------------------------------------|-----|--|
| M1 | Supply air fan | P2 | Pressure guard, extract air filter |
| M2 | Extract air fan | P3 | Pressure relay, supply air fan |
| M4 | Motor, rotor | B1 | Temperature sensor, supply air |
| F1 | Supply air filter | B3 | Temperature sensor, extract air |
| F2 | Extract air filter | B4 | Temperature sensor, outdoor air |
| HR-R | Rotary wheel-type heat exchanger | DA1 | Air damper, exhaust air (not standard) |
| F10 | Overheating thermostat, manual reset | DA2 | Air damper, outdoor air (not standard) |
| F20 | Overheating thermostat | EB1 | Electric Battery |
| P1 | Pressure guard, supply air filter | | |

Dimensioned drawing

Dimensions in mm

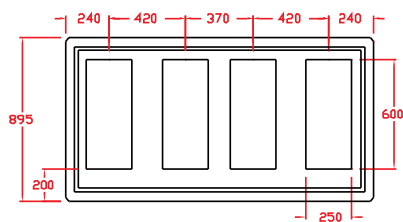
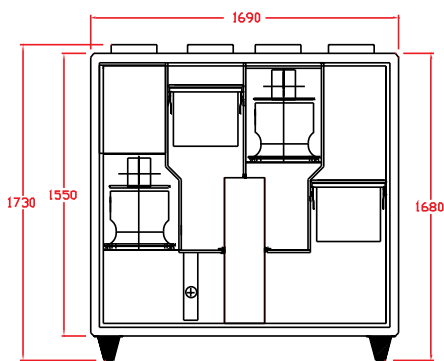

Shown as a right model.

Duct connection

Connection drawings and dimensions of nipples for the various unit variants;

RL = Rotor left, RR = Rotor right

RL

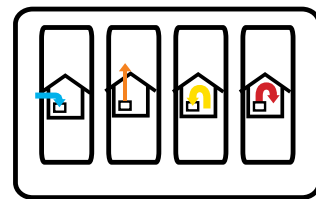

Front

RR

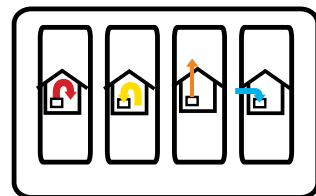

Front

Flexit S30 R

Capacity Diagram S30 R W/E (measured with an F7 filter)

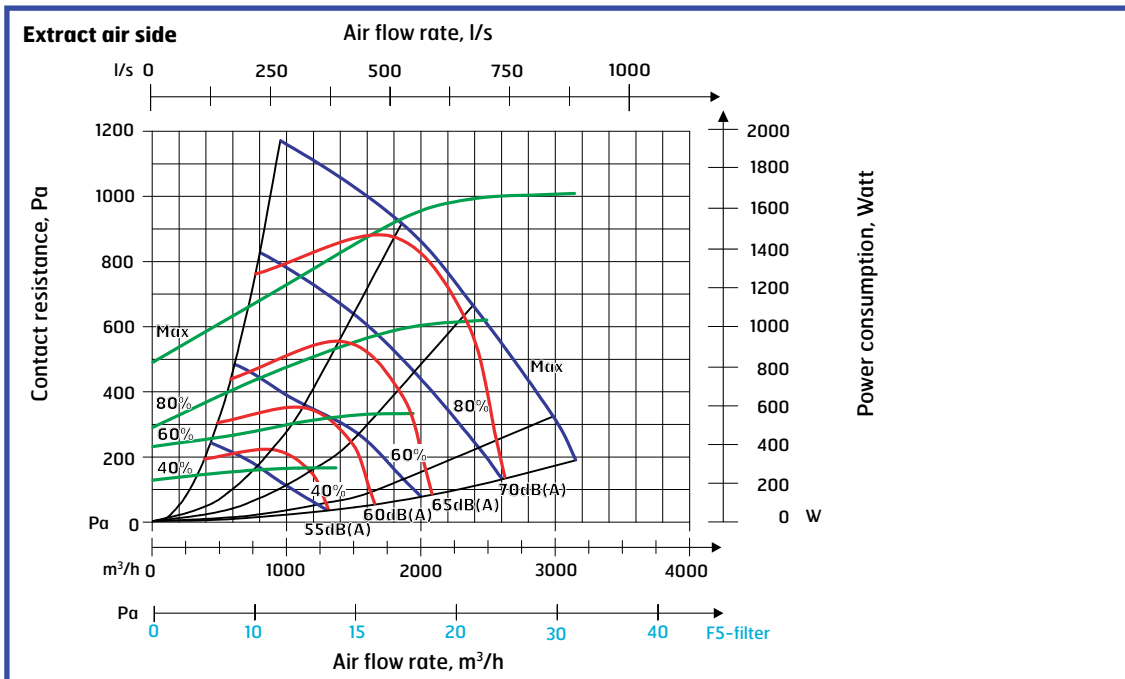
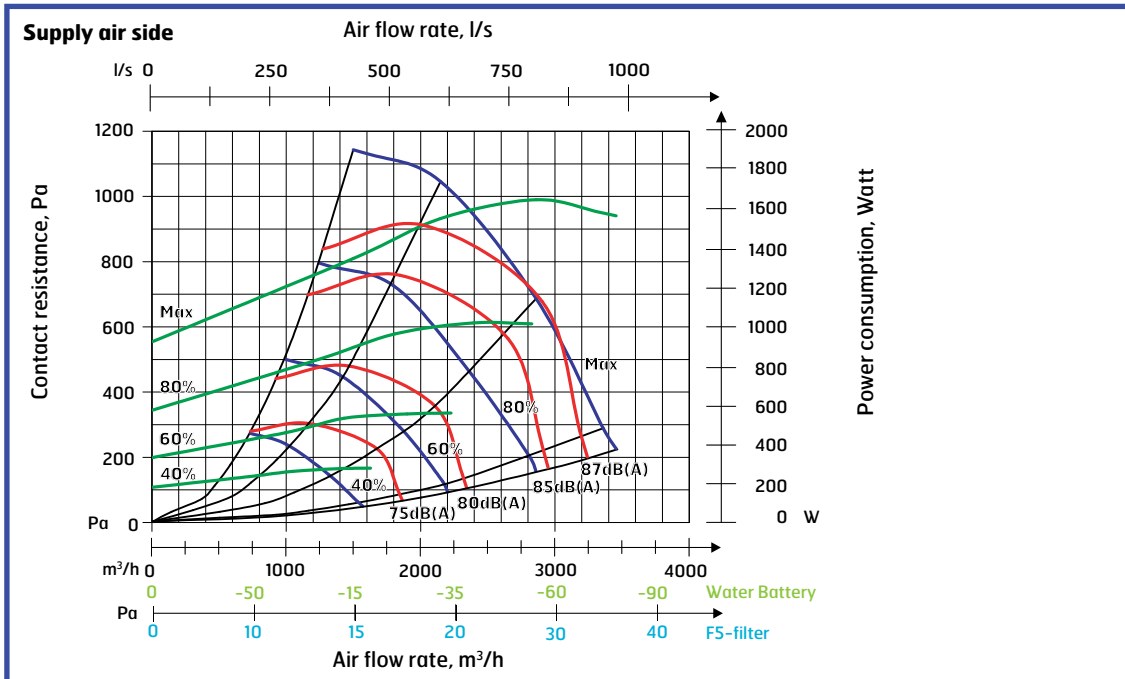

Sound data is given at sound power level L_{WA} in the capacity diagrams and is corrected with the table below for the various octave bands. Radiated noise produces L_w in the various octave bands and total L_{WA}. Radiated noise is calculated by taking the noise value from the supply air table and deducting the total value from the correction factor table.

Correction factor for L _w									
Hz	63	125	250	500	1000	2000	4000	8000	Total L _{WA}
Supply air	1	-1	2	-1	-6	-14	-24	-37	
Extract air	15	11	5	-5	-24	-35	-38	-46	
Radiated	-34	-26	-25	-34	-37	-33	-39	-48	-28

Supply air data is measured in accordance with ISO 5136, the in-duct method. Radiated noise is measured in accordance with ISO 9614-2. Bruel & Kjaer measuring equipment, type 2260.

Blue curves: Air capacity at various capacity settings in Volt.
Green curves: Supply air fan power consumption at various capacity settings.
Red curves: Sound power level L_{WA}, cf. correction table.
Light blue correction axis: Pressure increase using an EU-5 filter.
Light green correction axis: Pressure increase using water battery.