

Flexit S12 R

Art.no.	Type
14525	S12 RER 400V
14526	S12 REL 400V
14527	S12 RWR
14528	S12 RWL



CI 500 Control Panel included in all units.

	S12 RW	S12 RE
Rated voltage:	230 V	400 V
Fuse:	1 x 10 A	3 x 16 A
Rated current, total:	6 A	14 A
Rated power, total:	1 100 W	7 100 W
Rated power, electric battery:		6 000 W
Rated power, fans:	2 x 485 W	2 x 485 W
Rated power, preheating:		
Fan type:	B-wheel	B-wheel
Fan motor control:	EC-control system	EC-control system
Max. fan speed:	3 580 rpm	3 580 rpm
Filter type (SUP/EXTR):	F 7	F 7
Filter dimension (W x H x D):	2 x (592 x 294 x 250 mm)	2 x (592 x 294 x 250 mm)
Numbers of bags:	12	12
Weight:	200 kg	200 kg
Duct connection:	Ø 250 mm	Ø 250 mm
Height:	1 380 mm	1 380 mm
Width:	1 250 mm	1 250 mm
Depth:	700 mm	700 mm

Flexit S12 R

Accessories



Bag Filter

Art.no.	Type
12324	F7



Closing Air Damper w/Spring Return

Art.no.	Type
14485	Ø250 w/Spring Return
14476	Ø250 on/off



3-way Valve

Art.no.	Type
56232	KVS 1,6 3-way
56432	KVS 1,6 2-way
57228	KVS 2,5 3-way
56433	KVS 2,5 2-way
56072	fittings KVS 2,5



Motor 3-way Valve

Art.no.	Type
56234	0-10V



SP440 CO₂

Art.no.
09359



SP 435 Motion Detector

Art.no.
09358



SP 450 Motion Detector

Art.no.
09390



CC 1050 Pressure Sensor

Art.no.
09367



SP 445 Smoke Detector

Art.no.
09362

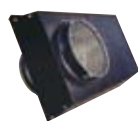

Combi. Unit

Art.no.	Type
14328	2xØ250mm, black
14331	2xØ315mm, black

Flexit S12 R

S12 RWR

System drawing, water-based heating

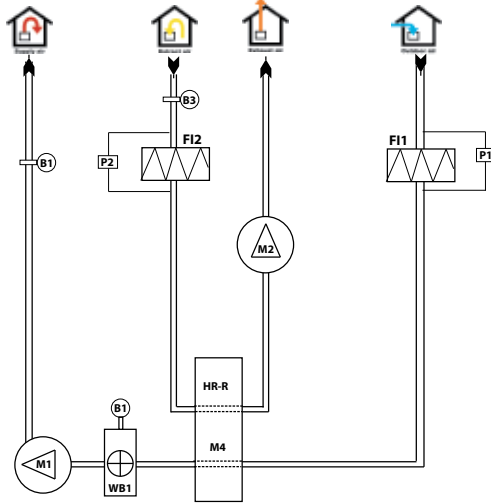

M1	Supply air fan	B3	Temperature sensor, extract air (not standard)
M2	Extract air fan	B4	Temperature sensor, outdoor air (not standard)
M4	Motor, rotor	B5	Temperature sensor, water battery (frost relay)
F11	Supply air filter	DA1	Air damper, exhaust air (not standard)
F12	Extract air filter	DA2	Air damper, outdoor air (not standard)
HR-R	Rotary wheel-type heat exchanger	WB1	Water Battery
P1	Pressure guard, supply air filter		
P2	Pressure guard, extract air filter		
B1	Temperature sensor, supply air		

S12 RER

System drawing, electric heating

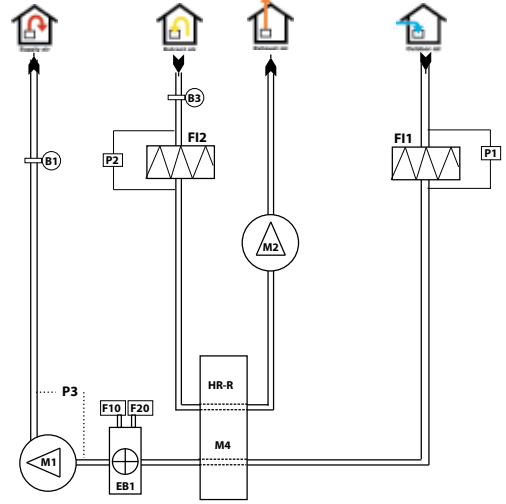

M1	Supply air fan		air filter
M2	Extract air fan	P3	Pressure relay, supply air fan
M4	Motor, rotor	B1	Temperature sensor, supply air
F11	Supply air filter	B3	Temperature sensor, extract air (not standard)
F12	Extract air filter	B4	Temperature sensor, outdoor air (not standard)
HR-R	Rotary wheel-type heat exchanger	DA1	Air damper, exhaust air (not standard)
F10	Overheating thermostat - manual reset	DA2	Air damper, outdoor air (not standard)
F20	Overheating thermostat - manual reset	EB1	Electric Battery
P1	Pressure guard, supply air filter		
P2	Pressure guard, extract		

Dimensioned drawing

Dimensions in mm

- rotor model, right

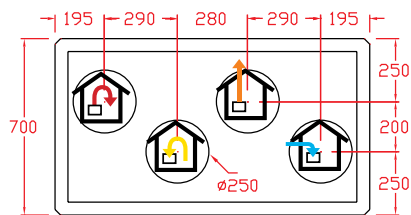
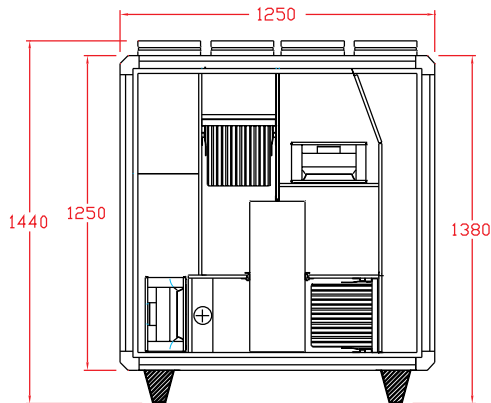

Front

Dimensioned drawing

Dimensions in mm

- rotor model, left

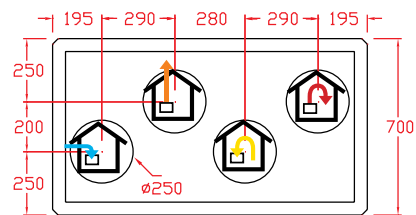
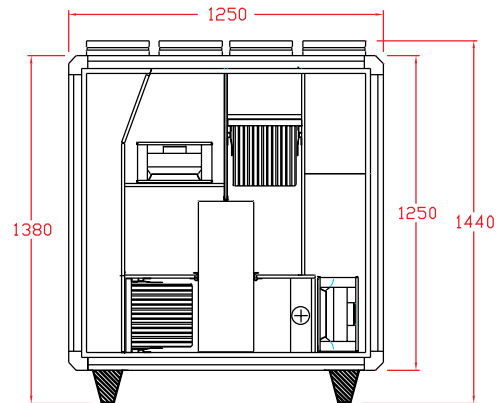

Front

Flexit S12 R

Capacity Diagram S12 R EC W/E (measured with F7 filter)

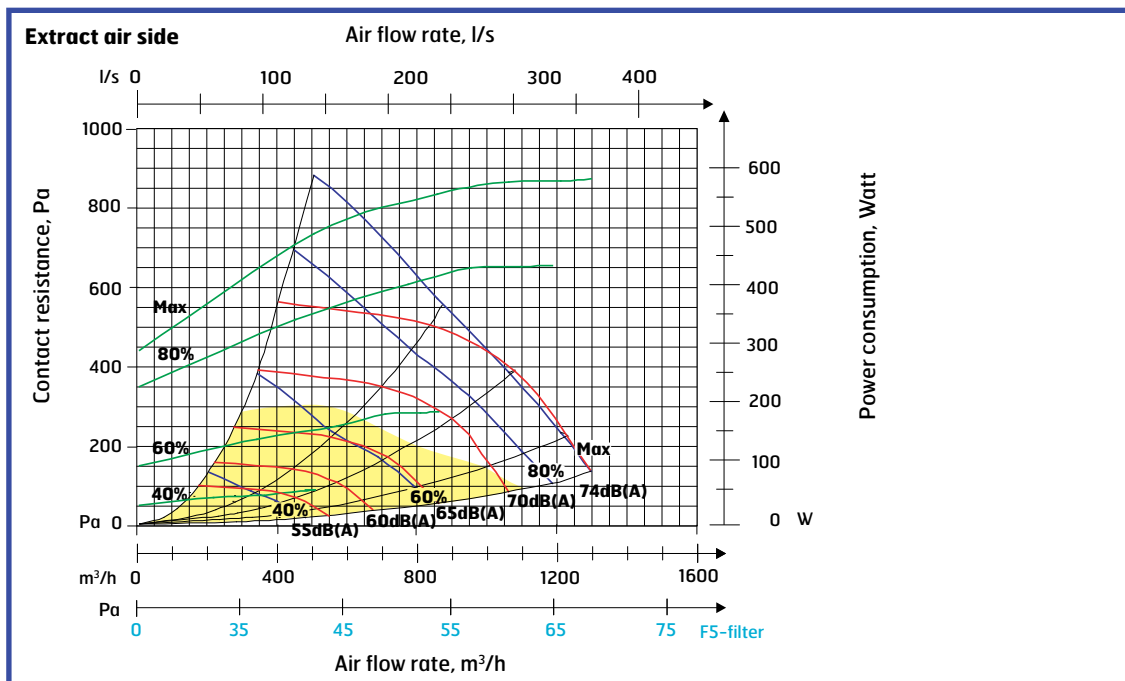
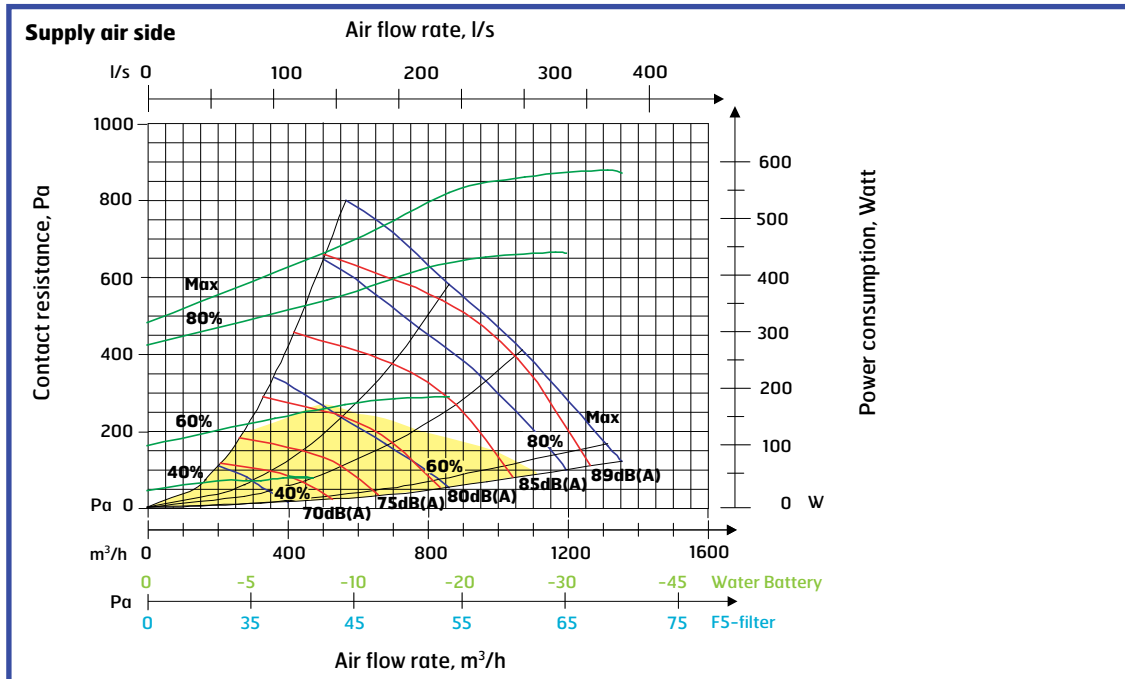

Yellow field: SFP < 1.25 per fan

$$SFP = \frac{P}{V} \text{ [kW/m}^3\text{/s]} = \text{J/m}^3$$

Sound data is given at sound power level L_{WA} in the capacity diagrams and is corrected with the table below for the various octave bands and is corrected with the table below for the various octave bands and total L_{WA}. Radiated noise is calculated by taking the noise value from the supply air table and deducting the total value from the correction factor table.

Supply air data is measured in accordance with ISO 5136, the in-duct method. Radiated noise is measured in accordance with ISO 9614-2. Bruel & Kjaer measuring equipment, type 2260.

Correction factor for L _w									
Hz	63	125	250	500	1000	2000	4000	8000	Total L _{WA}
Supply air	-5	-3	-2	0	-7	-10	-17	-30	
Extract air	10	7	-1	0	-13	-19	-30	-42	
Radiated	-40	-41	-37	-45	-43	-42	-45	-54	-36,6

Blue curves: Air capacity at various capacity settings in Volt.

Green curves: Supply air fan power consumption at various capacity settings.

Red curves: Sound power level L_{WA}, cf. correction table.

Light blue correction axe: Pressure increase using an EU-5 filter.

Light green correction axe: Pressure increase using water battery.