

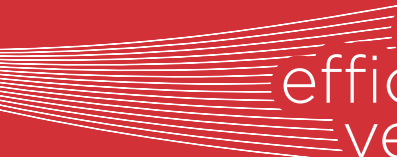

PRODUCT CATALOGUE 2021

# FANS

 energy  
efficient  
ventilation







Östberg supplies energy efficient and high performance ventilation products for a fresh and healthy indoor climate, wherever people live, work or play. Founded in Sweden in the early 1980s, Östberg has grown into a leading global supplier of duct fans and energy efficient air treatment units – with product sales in over 75 countries.

## healthy indoor climate

### FLEXIBLE AND CUSTOMISED

Consistent customer focus and great flexibility play key roles in Östberg's business concept. We consider it of particular importance to create a truly world-class indoor environment with the lowest possible energy consumption and sound levels. Our comprehensive product range features units and fans that can handle airflows from 20 litres to 1200 litres per second. All our products are CE-labelled for EU, EFTA and EEA markets, and we place great emphasis on making them simple to install and to use.

### RESEARCH AND PRODUCT DEVELOPMENT

To maintain and grow the position as a leading technical supplier of high end quality products, Östberg continuously invests heavily in innovation and product development. Our ideas for product development arise from collaborations with our customers, innovations by our technical experts, and from our desire to create even better indoor climates. In our efforts to continuously develop our products, we perform numerous tests and measurements – all in order to meet our customers needs and provide healthier air using energy efficient fan and ventilation products at competitive prices.

### QUALITY ASSURED PRODUCTS

Östberg upholds the highest standards for production, with secure quality controls monitoring each product throughout the entire manufacturing process. The company is certified according to the quality and environment standards ISO 9001 and ISO 14001. Östberg is headquartered in Sweden with branches in many countries all over the world.

By choosing an Östberg product you invest in long-lasting quality products powered by innovation.

# ÖSTBERG PRODUCT SYMBOLS

---



PRODUCTS WITH AC MOTORS  
Products marked with this symbol use AC motors.



PRODUCTS WITH EC MOTORS  
Products marked with this symbol use EC motors.



ErP 2015  
This product is compliant with the Lot 11 directive (327/2011) and approved for use in the EU and EFTA.



ErP 2018  
This product is compliant with the Lot 6 directive (1253/2014) and approved for use in the EU and EFTA.



ErP NOT REQUIRED  
This product is outside the scope of the Ecodesign directives but approved for use in the EU and EFTA.

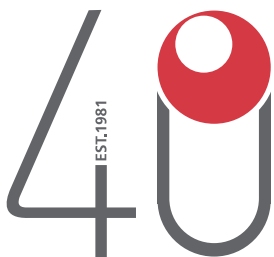

1981-2021  
Celebrating 40 Years Of Passion For Ventilation

In 2021, Östberg celebrates 40 years, but as early as 1973, Hans Östberg designed the world's first circular duct fan with straight flow, outer rotor motor and radial fan wheels. This construction had a significant part for the start of the company L H G Kanalfläkt AB, where Hans Östberg owned 1/3.

The design was groundbreaking and the fan type is manufactured and sold today by most fan manufacturers in the global market.

Welcome to celebrate with us!

# passion4ventilation #poweredbypassion # ostberg40years

Our compact radial fans are primarily intended for installation in various appliances, e.g. heat exchangers, dehumidifiers and air cleaners. They have impellers with forward-curved blades. In this category there are single-inlet RF and DF which are double-inlet.

## SINGEL INLET

**RF**..... 366  
The RF radial fans have a single inlet, single-phase. Is available with AC or EC motor.

**RB**..... 389  
The RB radial fans have a single inlet, single-phase. Is available with AC or EC motor.

## DOUBLE INLET

**DF**..... 392  
The DFE double inlet radial fans have an external rotor motor placed in the middle of the impeller, which makes a very compact design. Is available with AC motor.

# RADIAL FAN

## RFE 120 M

KU 7700123 UU 7700125, KR 7700295

- Single-phase single inlet radial fan.
- Compact with high capacity and efficiency.
- Low sound levels.
- Impeller with forward curved blades.
- The external rotor motor has maintenance-free sealed ball-bearings.
- The motor is situated in the airstream to get ultimate cooling.
- Integrated motor protection.
- Junction box has enclosure class IP 54.
- For speed control a transformer or electronic speed controller can be connected.
- Fan housing is manufactured from galvanized sheet steel.
- Ideal for use in heat exchangers, dehumidifiers and air cleaners.
- Explanations:  
KR = With junction box, with connection pipes.  
KU = With junction box, without connection pipes.  
UU = Without junction box, without connection pipes.
- All diagrams shown with duct connected fan.

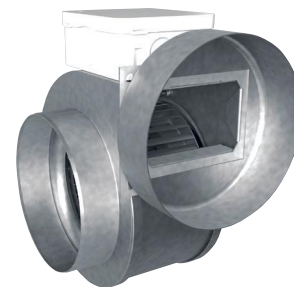

### ACCESSORIES

- Outlet flange
- Mounting clamp MK 125
- Safety grille BSV 125
- Safety grille BSR 125
- Back draught shutter RSK 125
- Louvre YG 125
- Silencer LDC 125
- Transformer controller VRTE C
- Transformer controller VRDE 1.5
- Speed controller VRS 0.5

### TECHNICAL DATA

|                                     |             |
|-------------------------------------|-------------|
| <b>Voltage</b>                      | 230 V       |
| <b>Frequency</b>                    | 50 Hz       |
| <b>Phase</b>                        | 1 ~         |
| <b>Current</b>                      | 0.29 A      |
| <b>Power</b>                        | 67 W        |
| <b>Speed</b>                        | 1510 r.p.m. |
| <b>Max. temp of transported air</b> | 75 °C       |
| <b>Sound pressure level, 3 m</b>    | 53 dB(A)    |
| <b>Weight</b>                       | 2.0 kg      |
| <b>Enclosure class</b>              | 44 IP       |
| <b>Wiring diagram</b>               | 4040001     |

### PRESSURE/FLOW

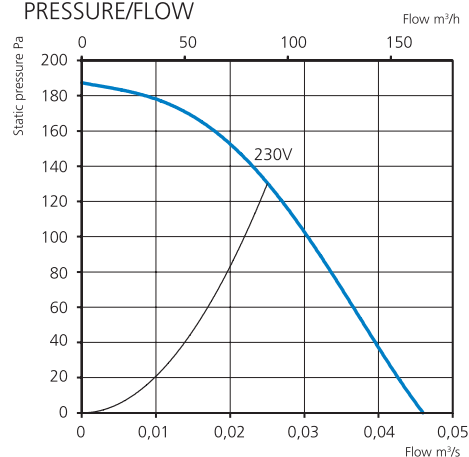

### POWER/FLOW

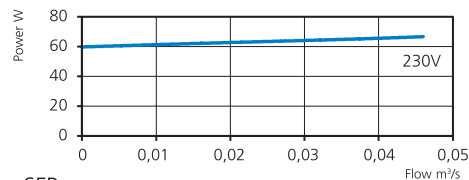

### SFP

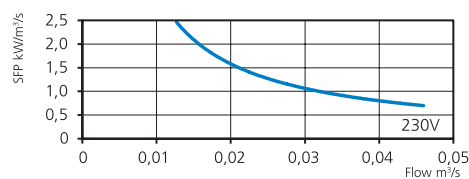

### SOUND DATA

|                          | $L_{wa}$ tot dB (A) | 63 | 125 | 250 | 500 | 1K | 2K | 4K | 8K |
|--------------------------|---------------------|----|-----|-----|-----|----|----|----|----|
| <b>Surrounding 230 V</b> | 60                  | 33 | 38  | 48  | 57  | 54 | 51 | 51 | 45 |
| <b>Outlet 230 V</b>      | 68                  | 58 | 56  | 60  | 64  | 59 | 52 | 50 | 45 |
| <b>Inlet 230 V</b>       | 66                  | 55 | 56  | 62  | 61  | 53 | 48 | 48 | 40 |

### MORE INFORMATION



Find out the latest updated information about this product by visiting [www.ostberg.com](http://www.ostberg.com) or scanning this QR code.

### DIMENSIONS (mm)

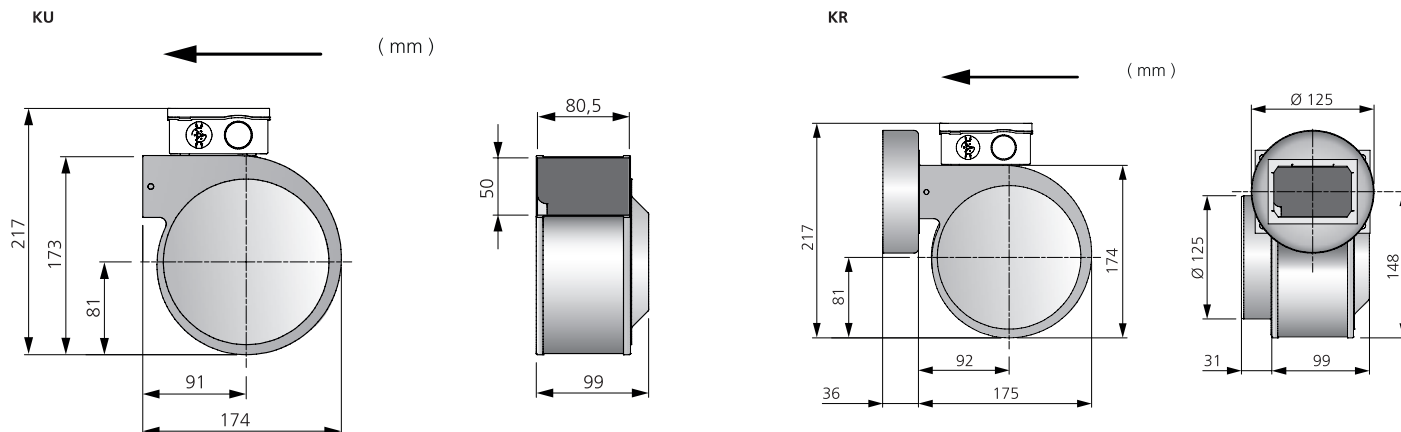





- Single-phase single inlet radial fan.
- Compact with high capacity and efficiency.
- Low sound levels.
- Impeller with forward curved blades.
- The external rotor motor has maintenance-free sealed ball-bearings.
- The motor is situated in the airstream to get ultimate cooling.
- Integrated motor protection.
- Junction box has enclosure class IP 54.
- For speed control a transformer or electronic speed controller can be connected.
- Fan housing is manufactured from galvanized sheet steel.
- Ideal for use in heat exchangers, dehumidifiers and air cleaners.
- Explanations:  
KR = With junction box, with connection pipes.  
KU = With junction box, without connection pipes.  
UU = Without junction box, without connection pipes.
- All diagrams shown with duct connected fan.

### PRESSURE/FLOW

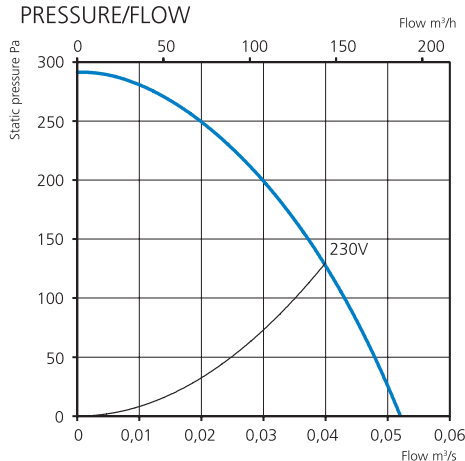

### TECHNICAL DATA

|                                     |             |
|-------------------------------------|-------------|
| <b>Voltage</b>                      | 230 V       |
| <b>Frequency</b>                    | 50 Hz       |
| <b>Phase</b>                        | 1 ~         |
| <b>Current</b>                      | 0.27 A      |
| <b>Power</b>                        | 62 W        |
| <b>Speed</b>                        | 1240 r.p.m. |
| <b>Max. temp of transported air</b> | 80 °C       |
| <b>Sound pressure level, 3 m</b>    | 53 dB(A)    |
| <b>Weight</b>                       | 2.7 kg      |
| <b>Enclosure class</b>              | 44 IP       |
| <b>Wiring diagram</b>               | 4040002     |

### ACCESSORIES

- Mounting clamp MK 125
- Safety grille BSV 125
- Safety grille BSR 125
- Back draught shutter RSK 125
- Louvre YG 125
- Silencer LDC 125
- Transformer controller VRTE C
- Transformer controller VRDE 1.5
- Speed controller VRS 0.5

### POWER/FLOW

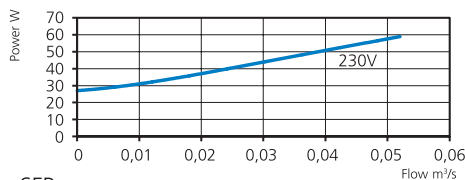

### SOUND DATA

|                          | $L_{wa}$ tot dB (A) | 63 | 125 | 250 | 500 | 1K | 2K | 4K | 8K |
|--------------------------|---------------------|----|-----|-----|-----|----|----|----|----|
| <b>Surrounding 230 V</b> | 60                  | 34 | 42  | 48  | 53  | 54 | 54 | 51 | 44 |
| <b>Outlet 230 V</b>      | 69                  | 54 | 61  | 64  | 62  | 60 | 56 | 57 | 53 |
| <b>Inlet 230 V</b>       | 67                  | 50 | 59  | 63  | 60  | 55 | 52 | 53 | 48 |

### SFP

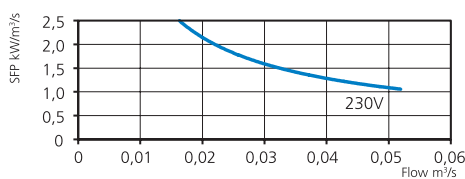

### MORE INFORMATION



Find out the latest updated information about this product by visiting [www.ostberg.com](http://www.ostberg.com) or scanning this QR code.

### DIMENSIONS (mm)

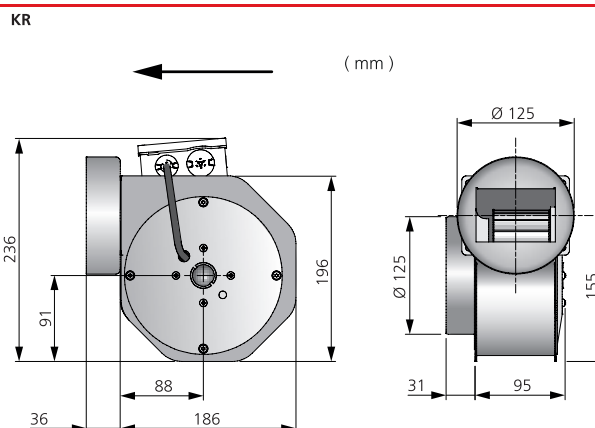
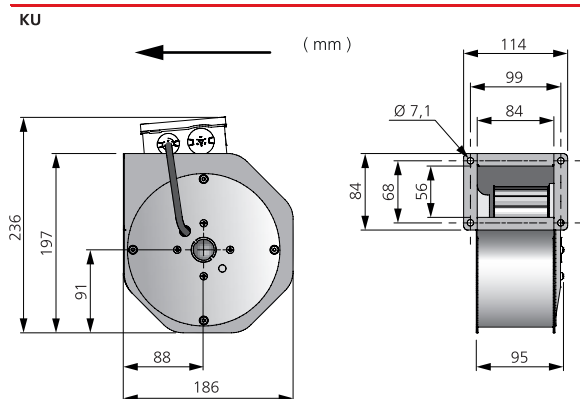

# RADIAL FAN

## RFE 140 M

KU 7700005, UU 7700004, KR 7700006

- Single-phase single inlet radial fan.
- Compact with high capacity and efficiency.
- Low sound levels.
- Impeller with forward curved blades.
- The external rotor motor has maintenance-free sealed ball-bearings.
- The motor is situated in the airstream to get ultimate cooling.
- Integrated motor protection.
- Junction box has enclosure class IP 54.
- For speed control a transformer or electronic speed controller can be connected.
- Fan housing is manufactured from galvanized sheet steel.
- Ideal for use in heat exchangers, dehumidifiers and air cleaners.
- Explanations:  
KR = With junction box, with connection pipes.  
KU = With junction box, without connection pipes.  
UU = Without junction box, without connection pipes.
- All diagrams shown with duct connected fan.



### ACCESSORIES

- Mounting clamp MK 125
- Safety grille BSV 125
- Safety grille BSR 125
- Back draught shutter RSK 125
- Louvre YG 125
- Silencer LDC 125
- Transformer controller VRTE C
- Transformer controller VRDE 1.5
- Speed controller VRS 0.5

### TECHNICAL DATA

|                                     |             |
|-------------------------------------|-------------|
| <b>Voltage</b>                      | 230 V       |
| <b>Frequency</b>                    | 50 Hz       |
| <b>Phase</b>                        | 1 ~         |
| <b>Current</b>                      | 0.41 A      |
| <b>Power</b>                        | 94 W        |
| <b>Speed</b>                        | 1940 r.p.m. |
| <b>Max. temp of transported air</b> | 80 °C       |
| <b>Sound pressure level, 3 m</b>    | 63 dB(A)    |
| <b>Weight</b>                       | 2.7 kg      |
| <b>Enclosure class</b>              | 44 IP       |
| <b>Wiring diagram</b>               | 4040001     |

### PRESSURE/FLOW

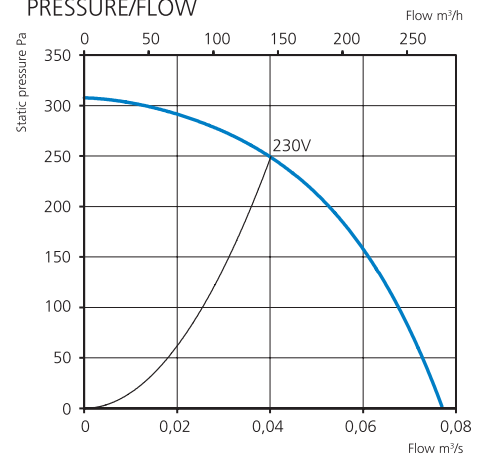

### POWER/FLOW

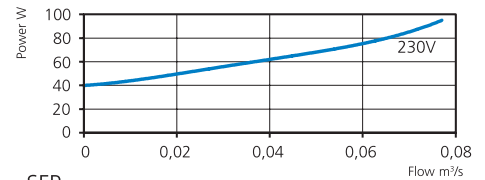

### SFP

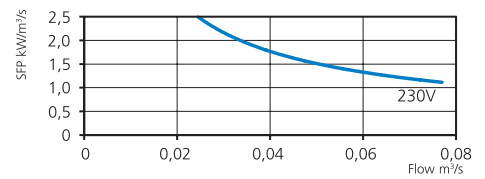

### SOUND DATA

|                          | $L_{WA}$ tot dB (A) | 63 | 125 | 250 | 500 | 1K | 2K | 4K | 8K |
|--------------------------|---------------------|----|-----|-----|-----|----|----|----|----|
| <b>Surrounding 230 V</b> | 70                  | 49 | 49  | 58  | 63  | 64 | 65 | 62 | 60 |
| <b>Outlet 230 V</b>      | 76                  | 67 | 67  | 68  | 69  | 67 | 69 | 65 | 62 |
| <b>Inlet 230 V</b>       | 74                  | 54 | 66  | 69  | 68  | 65 | 64 | 64 | 61 |

### MORE INFORMATION



Find out the latest updated information about this product by visiting [www.ostberg.com](http://www.ostberg.com) or scanning this QR code.

### DIMENSIONS (mm)

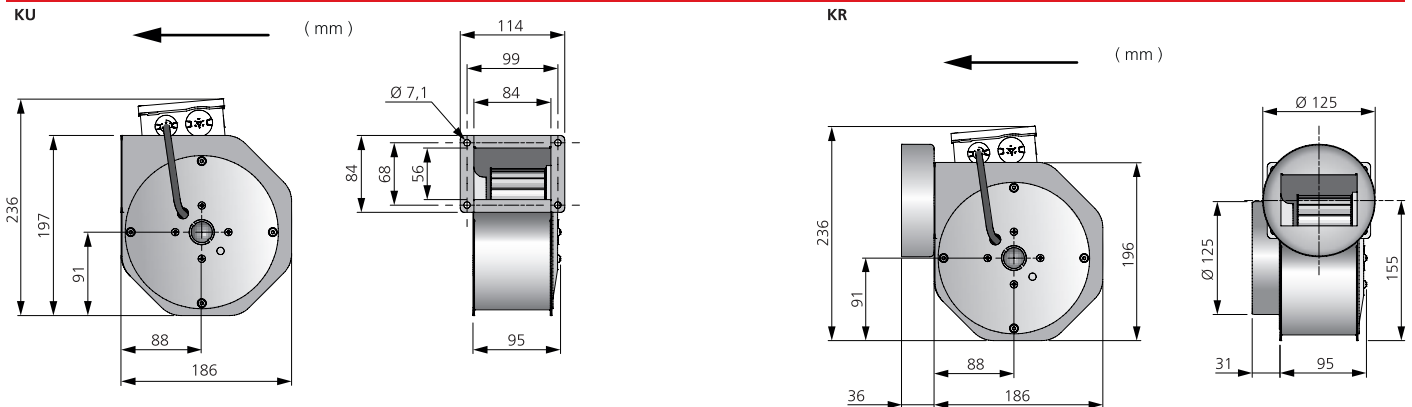



- Single-phase single inlet radial fan.
- Compact with high capacity and efficiency.
- Low sound levels.
- Impeller with forward curved blades.
- The external rotor motor has maintenance-free sealed ball-bearings.
- The motor is situated in the airstream to get ultimate cooling.
- Integrated motor protection.
- Junction box has enclosure class IP 54.
- For speed control a transformer or electronic speed controller can be connected.
- Fan housing is manufactured from galvanized sheet steel.
- Ideal for use in heat exchangers, dehumidifiers and air cleaners.
- Explanations:  
KR = With junction box, with connection pipes.  
KU = With junction box, without connection pipes.  
UU = Without junction box, without connection pipes.
- All diagrams shown with duct connected fan.

PRESSURE/FLOW

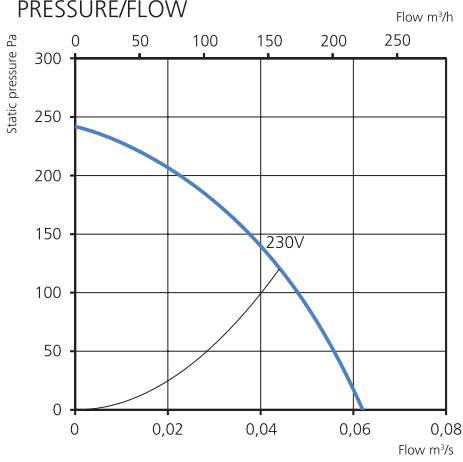

POWER/FLOW

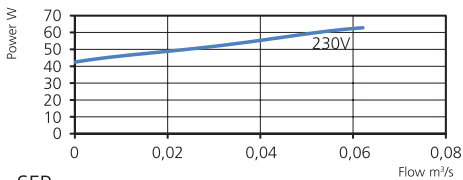

SFP

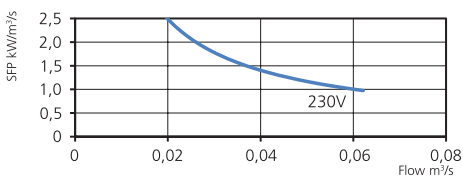

TECHNICAL DATA

|                                     |            |
|-------------------------------------|------------|
| <b>Voltage</b>                      | 230 V      |
| <b>Frequency</b>                    | 50 Hz      |
| <b>Phase</b>                        | 1 ~        |
| <b>Current</b>                      | 0.28 A     |
| <b>Power</b>                        | 62 W       |
| <b>Speed</b>                        | 830 r.p.m. |
| <b>Max. temp of transported air</b> | 70 °C      |
| <b>Sound pressure level, 3 m</b>    | 49 dB(A)   |
| <b>Weight</b>                       | 2.9 kg     |
| <b>Enclosure class</b>              | 44 IP      |
| <b>Wiring diagram</b>               | 4040002    |

ACCESSORIES

- Mounting clamp MK 160
- Safety grille BSV 160
- Safety grille BSR 160
- Back draught shutter RSK 160
- Louvre YG 160
- Silencer LDC 160
- Transformer controller VRTE C
- Transformer controller VRDE 1.5
- Speed controller VRS 0.5

SOUND DATA

|                          | $L_{wa}$ tot dB (A) | 63 | 125 | 250 | 500 | 1K | 2K | 4K | 8K |
|--------------------------|---------------------|----|-----|-----|-----|----|----|----|----|
| <b>Surrounding 230 V</b> | 56                  | 31 | 33  | 44  | 49  | 51 | 50 | 47 | 40 |
| <b>Outlet 230 V</b>      | 65                  | 50 | 58  | 58  | 58  | 59 | 54 | 52 | 47 |
| <b>Inlet 230 V</b>       | 63                  | 49 | 57  | 58  | 57  | 53 | 51 | 50 | 43 |

MORE INFORMATION



Find out the latest updated information about this product by visiting [www.ostberg.com](http://www.ostberg.com) or scanning this QR code.

DIMENSIONS (mm)

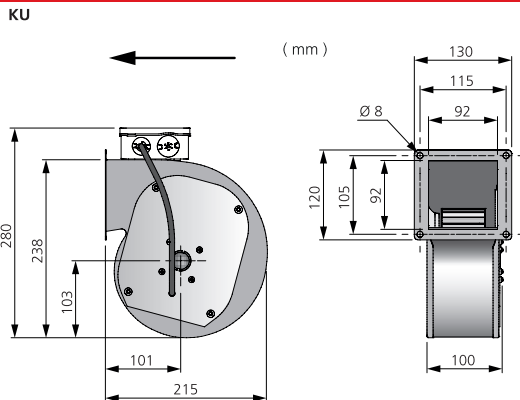

# RADIAL FAN

## RFE 140 B

KU 77202117720211, UU 7720206, KR 7720216

- Single-phase single inlet radial fan.
- Compact with high capacity and efficiency.
- Low sound levels.
- Impeller with forward curved blades.
- The external rotor motor has maintenance-free sealed ball-bearings.
- The motor is situated in the airstream to get ultimate cooling.
- Integrated motor protection.
- Junction box has enclosure class IP 54.
- For speed control a transformer or electronic speed controller can be connected.
- Fan housing is manufactured from galvanized sheet steel.
- Ideal for use in heat exchangers, dehumidifiers and air cleaners.
- Explanations:  
KR = With junction box, with connection pipes.  
KU = With junction box, without connection pipes.  
UU = Without junction box, without connection pipes.
- All diagrams shown with duct connected fan.



### ACCESSORIES

- Mounting clamp MK 160
- Safety grille BSV 160
- Safety grille BSR 160
- Back draught shutter RSK 160
- Louvre YG 160
- Silencer LDC 160
- Transformer controller VRTE C
- Transformer controller VRDE 1.5
- Speed controller VRS 1.0

### TECHNICAL DATA

|                                     |             |
|-------------------------------------|-------------|
| <b>Voltage</b>                      | 230 V       |
| <b>Frequency</b>                    | 50 Hz       |
| <b>Phase</b>                        | 1 ~         |
| <b>Current</b>                      | 0.46 A      |
| <b>Power</b>                        | 105 W       |
| <b>Speed</b>                        | 1190 r.p.m. |
| <b>Max. temp of transported air</b> | 60 °C       |
| <b>Sound pressure level, 3 m</b>    | 59 dB(A)    |
| <b>Weight</b>                       | 2.9 kg      |
| <b>Enclosure class</b>              | 44 IP       |
| <b>Wiring diagram</b>               | 4040001     |

### PRESSURE/FLOW

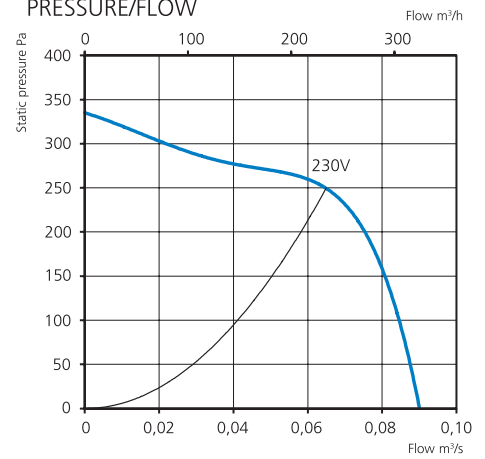

### POWER/FLOW

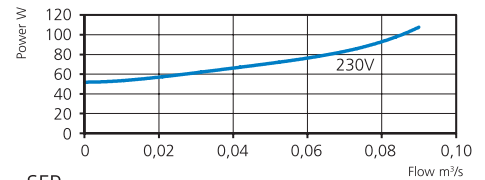

### SFP

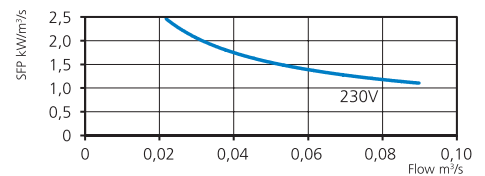

### SOUND DATA

|                          | $L_{WA}$ tot dB (A) | 63 | 125 | 250 | 500 | 1K | 2K | 4K | 8K |
|--------------------------|---------------------|----|-----|-----|-----|----|----|----|----|
| <b>Surrounding 230 V</b> | 66                  | 41 | 43  | 54  | 58  | 58 | 60 | 59 | 52 |
| <b>Outlet 230 V</b>      | 73                  | 56 | 63  | 65  | 66  | 65 | 63 | 65 | 60 |
| <b>Inlet 230 V</b>       | 71                  | 56 | 64  | 65  | 65  | 60 | 60 | 59 | 56 |

### MORE INFORMATION



Find out the latest updated information about this product by visiting [www.ostberg.com](http://www.ostberg.com) or scanning this QR code.

### DIMENSIONS (mm)

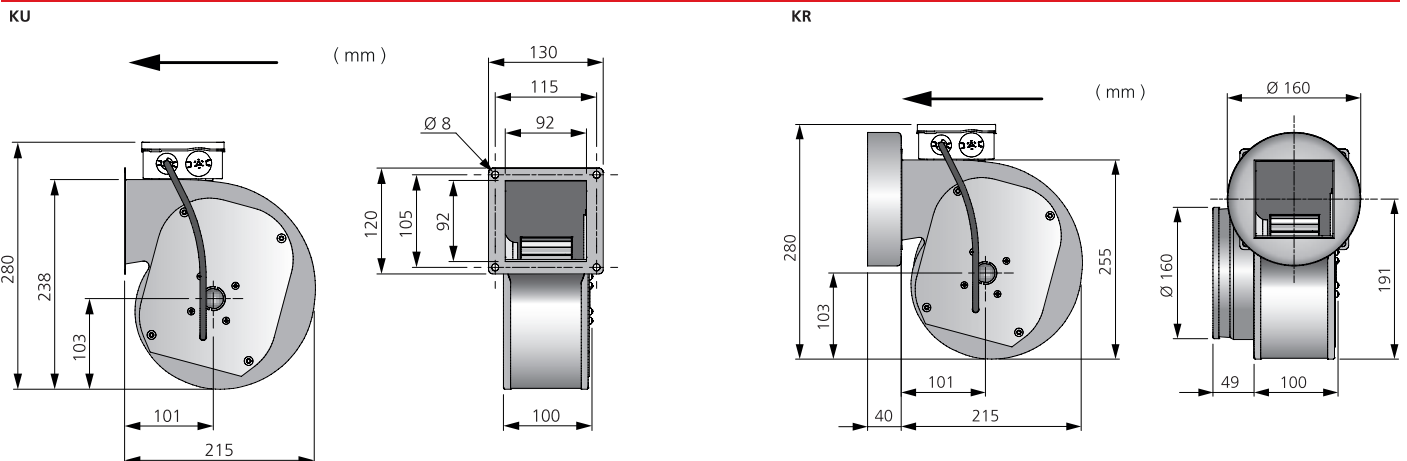



- Single-phase single inlet radial fan.
- Compact with high capacity and efficiency.
- Low sound levels.
- Impeller with forward curved blades.
- The external rotor motor has maintenance-free sealed ball-bearings.
- The motor is situated in the airstream to get ultimate cooling.
- Integrated motor protection.
- Junction box has enclosure class IP 54.
- For speed control a transformer or electronic speed controller can be connected.
- Fan housing is manufactured from galvanized sheet steel.
- Ideal for use in heat exchangers, dehumidifiers and air cleaners.
- Explanations:  
KR = With junction box, with connection pipes.  
KU = With junction box, without connection pipes.  
UU = Without junction box, without connection pipes.
- All diagrams shown with duct connected fan.

### PRESSURE/FLOW

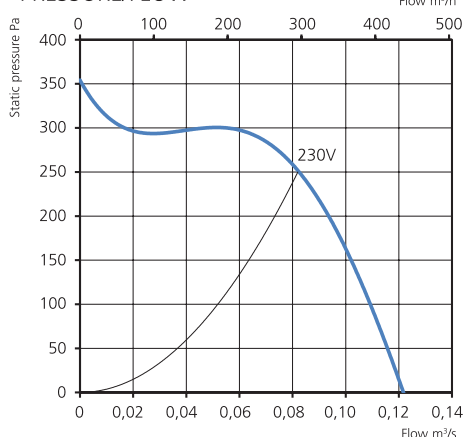

### POWER/FLOW

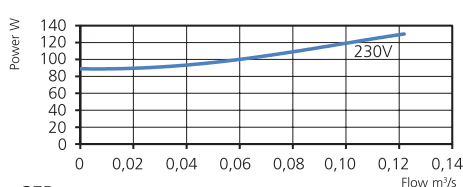

### SFP

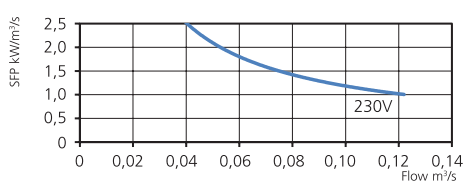

### TECHNICAL DATA

|                                     |             |
|-------------------------------------|-------------|
| <b>Voltage</b>                      | 230 V       |
| <b>Frequency</b>                    | 50 Hz       |
| <b>Phase</b>                        | 1 ~         |
| <b>Current</b>                      | 0.56 A      |
| <b>Power</b>                        | 129 W       |
| <b>Speed</b>                        | 1700 r.p.m. |
| <b>Max. temp of transported air</b> | 60 °C       |
| <b>Sound pressure level, 3 m</b>    | 60 dB(A)    |
| <b>Weight</b>                       | 2.9 kg      |
| <b>Enclosure class</b>              | 44 IP       |
| <b>Wiring diagram</b>               | 4040001     |

### ACCESSORIES

- Mounting clamp MK 160
- Safety grille BSV 160
- Safety grille BSR 160
- Back draught shutter RSK 160
- Louvre YG 160
- Silencer LDC 160
- Transformer controller VRTE C
- Transformer controller VRDE 1.5
- Speed controller VRS 1.0

### SOUND DATA

|                          | $L_{wa}$ tot dB (A) | 63 | 125 | 250 | 500 | 1K | 2K | 4K | 8K |
|--------------------------|---------------------|----|-----|-----|-----|----|----|----|----|
| <b>Surrounding 230 V</b> | 67                  | 40 | 43  | 55  | 60  | 59 | 62 | 60 | 53 |
| <b>Outlet 230 V</b>      | 74                  | 56 | 63  | 67  | 68  | 67 | 66 | 64 | 64 |
| <b>Inlet 230 V</b>       | 72                  | 53 | 60  | 67  | 67  | 59 | 60 | 60 | 57 |

### MORE INFORMATION



Find out the latest updated information about this product by visiting [www.ostberg.com](http://www.ostberg.com) or scanning this QR code.

### DIMENSIONS (mm)

KU

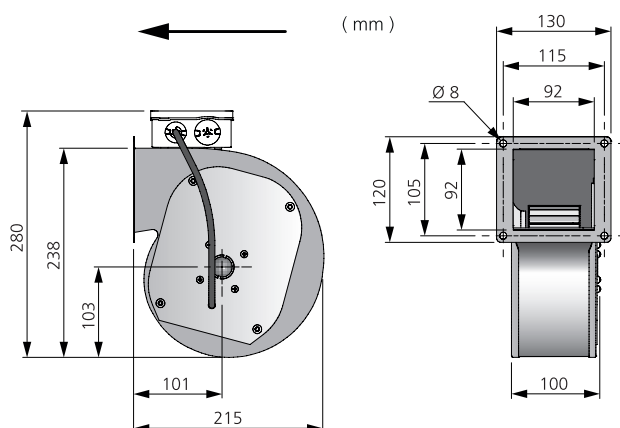

KR

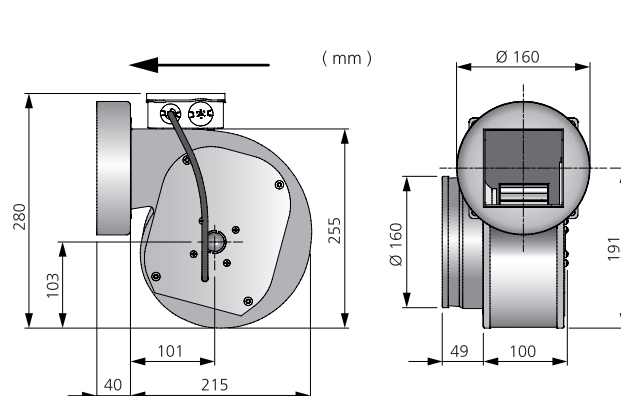

# RADIAL FAN

## RFE 140 D

KU 7720254, UU 7720253, KR 7720256

- Single-phase single inlet radial fan.
- Compact with high capacity and efficiency.
- Low sound levels.
- Impeller with forward curved blades.
- The external rotor motor has maintenance-free sealed ball-bearings.
- The motor is situated in the airstream to get ultimate cooling.
- Integrated motor protection.
- Junction box has enclosure class IP 54.
- For speed control a transformer or electronic speed controller can be connected.
- Fan housing is manufactured from galvanized sheet steel.
- Ideal for use in heat exchangers, dehumidifiers and air cleaners.
- Explanations:  
KR = With junction box, with connection pipes.  
KU = With junction box, without connection pipes.  
UU = Without junction box, without connection pipes.
- All diagrams shown with duct connected fan.



### ACCESSORIES

- Mounting clamp MK 160
- Safety grille BSV 160
- Safety grille BSR 160
- Back draught shutter RSK 160
- Louvre YG 160
- Silencer LDC 160
- Transformer controller VRTE C
- Transformer controller VRDE 1.5
- Speed controller VRS 1.0

### TECHNICAL DATA

|                                     |             |
|-------------------------------------|-------------|
| <b>Voltage</b>                      | 230 V       |
| <b>Frequency</b>                    | 50 Hz       |
| <b>Phase</b>                        | 1 ~         |
| <b>Current</b>                      | 0.86 A      |
| <b>Power</b>                        | 198 W       |
| <b>Speed</b>                        | 1800 r.p.m. |
| <b>Max. temp of transported air</b> | 60 °C       |
| <b>Sound pressure level, 3 m</b>    | 45 dB(A)    |
| <b>Weight</b>                       | 3.4 kg      |
| <b>Enclosure class</b>              | 44 IP       |
| <b>Wiring diagram</b>               | 4040001     |

### PRESSURE/FLOW

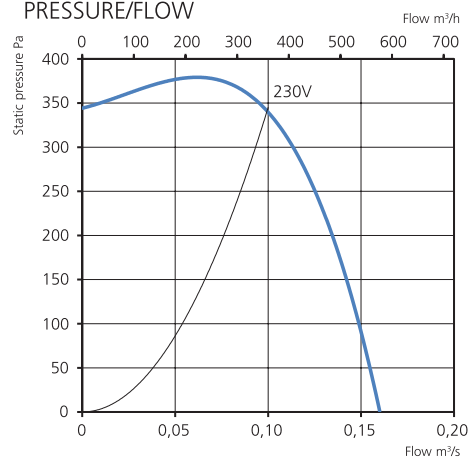

### POWER/FLOW

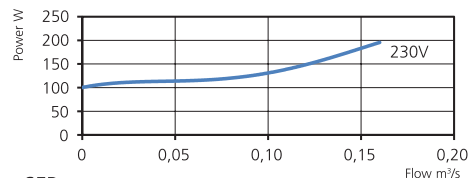

### SFP

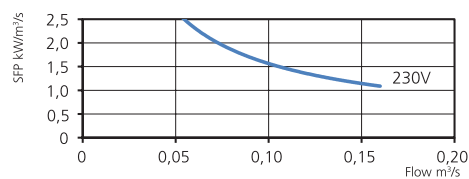

### SOUND DATA

|                          | $L_{wa}$ tot dB (A) | 63 | 125 | 250 | 500 | 1K | 2K | 4K | 8K |
|--------------------------|---------------------|----|-----|-----|-----|----|----|----|----|
| <b>Surrounding 230 V</b> | 52                  | 22 | 35  | 45  | 43  | 46 | 46 | 44 | 40 |
| <b>Outlet 230 V</b>      | 78                  | 62 | 68  | 73  | 71  | 69 | 68 | 68 | 69 |
| <b>Inlet 230 V</b>       | 75                  | 56 | 68  | 70  | 69  | 63 | 66 | 65 | 63 |

### MORE INFORMATION



Find out the latest updated information about this product by visiting [www.ostberg.com](http://www.ostberg.com) or scanning this QR code.

### DIMENSIONS (mm)

KU

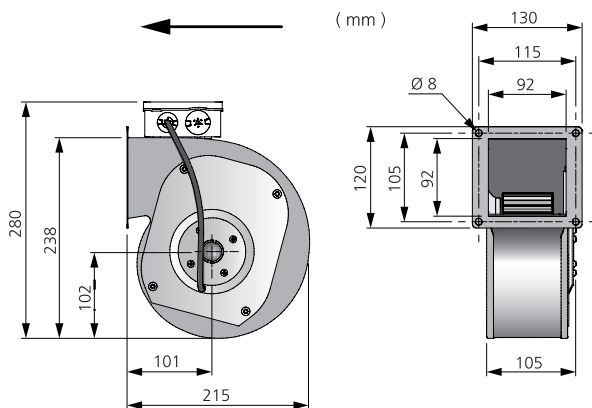

KR

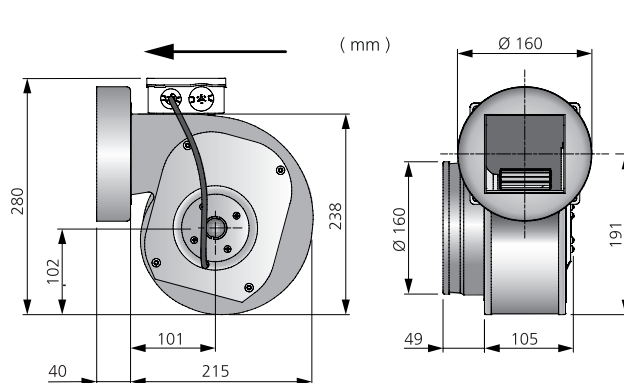

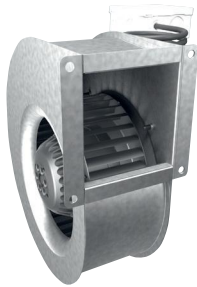

- Single-phase single inlet radial fan.
- Compact with high capacity and efficiency.
- Low sound levels.
- Impeller with forward curved blades.
- The external rotor motor has maintenance-free sealed ball-bearings.
- The motor is situated in the airstream to get ultimate cooling.
- Integrated motor protection.
- Junction box has enclosure class IP 54.
- For speed control a transformer or electronic speed controller can be connected.
- Fan housing is manufactured from galvanized sheet steel.
- Ideal for use in heat exchangers, dehumidifiers and air cleaners.
- Explanations:  
KR = With junction box, with connection pipes.  
KU = With junction box, without connection pipes.  
UU = Without junction box, without connection pipes.
- All diagrams shown with duct connected fan.

PRESSURE/FLOW

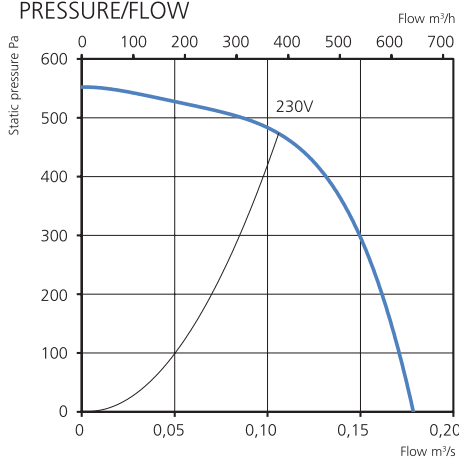

TECHNICAL DATA

|                                     |             |
|-------------------------------------|-------------|
| <b>Voltage</b>                      | 230 V       |
| <b>Frequency</b>                    | 50 Hz       |
| <b>Phase</b>                        | 1 ~         |
| <b>Current</b>                      | 1.3 A       |
| <b>Power</b>                        | 301 W       |
| <b>Speed</b>                        | 2150 r.p.m. |
| <b>Max. temp of transported air</b> | 50 °C       |
| <b>Sound pressure level, 3 m</b>    | 63.8 dB(A)  |
| <b>Weight</b>                       | 4 kg        |
| <b>Enclosure class</b>              | 44 IP       |
| <b>Wiring diagram</b>               | 4040001     |

ACCESSORIES

- Transformer controller VRDE 1.5
- Speed controller VRS 2.0
- Transformer controller VRTE 1

POWER/FLOW

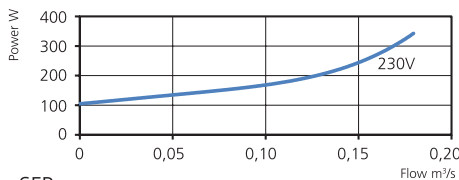

SOUND DATA

|                          | $L_{wa}$ tot dB (A) | 63 | 125 | 250 | 500 | 1K | 2K | 4K | 8K |
|--------------------------|---------------------|----|-----|-----|-----|----|----|----|----|
| <b>Surrounding 230 V</b> | 71                  | 41 | 49  | 61  | 63  | 63 | 66 | 63 | 58 |
| <b>Outlet 230 V</b>      | 79                  | 61 | 66  | 69  | 71  | 72 | 71 | 70 | 68 |
| <b>Inlet 230 V</b>       | 75                  | 59 | 65  | 70  | 67  | 66 | 66 | 64 | 62 |

SFP

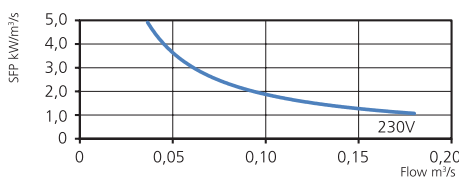

MORE INFORMATION



Find out the latest updated information about this product by visiting [www.ostberg.com](http://www.ostberg.com) or scanning this QR code.

DIMENSIONS (mm)

KU

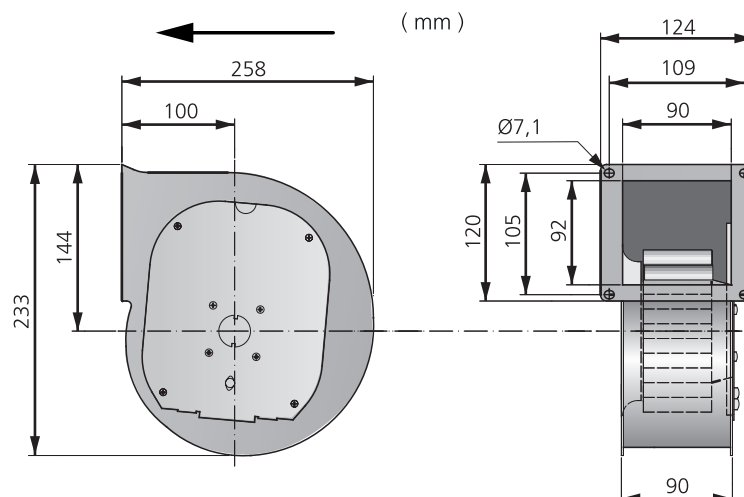

# RADIAL FAN

## RFE 200 C

KU 7710016, KR 7710017

- Single-phase single inlet radial fan.
- Compact with high capacity and efficiency.
- Low sound levels.
- Impeller with forward curved blades.
- The external rotor motor has maintenance-free sealed ball-bearings.
- The motor is situated in the airstream to get ultimate cooling.
- Integrated motor protection.
- Junction box has enclosure class IP 54.
- For speed control a transformer or electronic speed controller can be connected.
- Fan housing is manufactured from galvanized sheet steel.
- Ideal for use in heat exchangers, dehumidifiers and air cleaners.
- Explanations:  
KR = With junction box, with connection pipes.  
KU = With junction box, without connection pipes.  
UU = Without junction box, without connection pipes.
- All diagrams shown with duct connected fan.



### ACCESSORIES

- Mounting clamp MK 200
- Safety grille BSV 200
- Safety grille BSR 200
- Back draught shutter RSK 200
- Louvre YG 200
- Silencer LDC 200
- Transformer controller VRTE C
- Transformer controller VRDE 1.5
- Speed controller VRS 1.0

### TECHNICAL DATA

|                                     |             |
|-------------------------------------|-------------|
| <b>Voltage</b>                      | 230 V       |
| <b>Frequency</b>                    | 50 Hz       |
| <b>Phase</b>                        | 1 ~         |
| <b>Current</b>                      | 0.83 A      |
| <b>Power</b>                        | 190 W       |
| <b>Speed</b>                        | 1200 r.p.m. |
| <b>Max. temp of transported air</b> | 50 °C       |
| <b>Sound pressure level, 3 m</b>    | 57 dB(A)    |
| <b>Weight</b>                       | 6 kg        |
| <b>Enclosure class</b>              | 44 IP       |
| <b>Wiring diagram</b>               | 4040001     |

### PRESSURE/FLOW

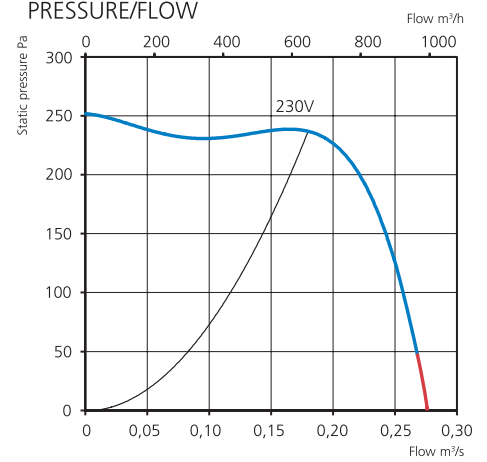

### POWER/FLOW

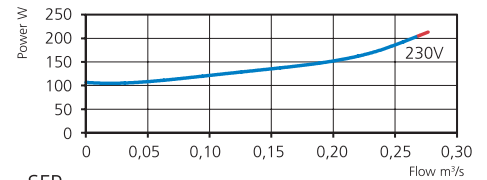

### SFP

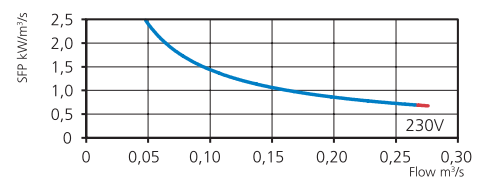

### SOUND DATA

|                          | $L_{wa}$ tot dB (A) | 63 | 125 | 250 | 500 | 1K | 2K | 4K | 8K |
|--------------------------|---------------------|----|-----|-----|-----|----|----|----|----|
| <b>Surrounding 230 V</b> | 64                  | 43 | 47  | 57  | 54  | 58 | 57 | 54 | 46 |
| <b>Outlet 230 V</b>      | 72                  | 57 | 58  | 66  | 64  | 67 | 62 | 63 | 57 |
| <b>Inlet 230 V</b>       | 69                  | 57 | 60  | 64  | 58  | 61 | 58 | 58 | 50 |

### MORE INFORMATION



Find out the latest updated information about this product by visiting [www.ostberg.com](http://www.ostberg.com) or scanning this QR code.

### DIMENSIONS (mm)

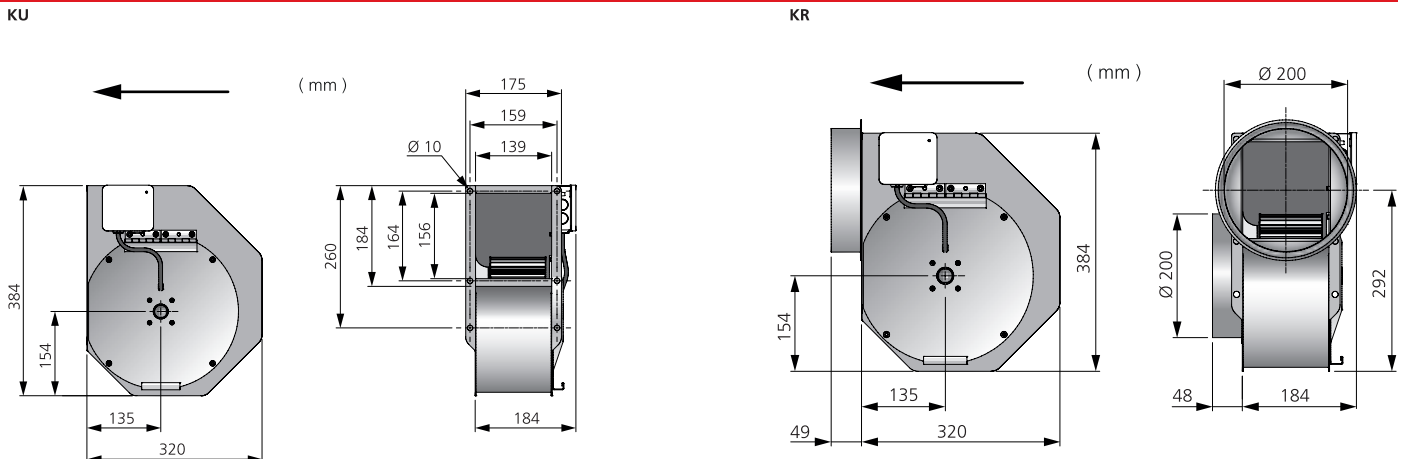





- 3-phase single inlet radial fan.
- Compact with high capacity and efficiency.
- Low sound levels.
- Impeller with forward curved blades.
- The external rotor motor has maintenance-free sealed ball-bearings.
- The motor is situated in the airstream to get ultimate cooling.
- Integrated motor protection.
- Junction box has enclosure class IP 54.
- For speed control a transformer or electronic speed controller can be connected.
- Fan housing is manufactured from galvanized sheet steel.
- Ideal for use in heat exchangers, dehumidifiers and air cleaners.
- Explanations:  
KR = With junction box, with connection pipes.  
KU = With junction box, without connection pipes.  
UU = Without junction box, without connection pipes.
- All diagrams shown with duct connected fan.

### PRESSURE/FLOW

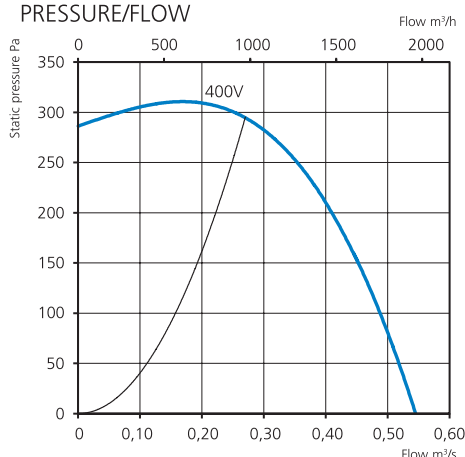

### POWER/FLOW

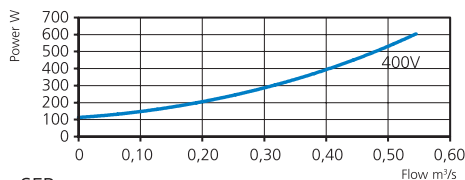

### SFP

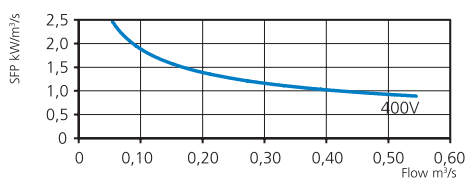

### TECHNICAL DATA

|                                     |             |
|-------------------------------------|-------------|
| <b>Voltage</b>                      | 400 V       |
| <b>Frequency</b>                    | 50 Hz       |
| <b>Phase</b>                        | 3 ~         |
| <b>Current</b>                      | 0.82 A      |
| <b>Power</b>                        | 445 W       |
| <b>Speed</b>                        | 1328 r.p.m. |
| <b>Max. temp of transported air</b> | 60 °C       |
| <b>Sound pressure level, 3 m</b>    | 66 dB(A)    |
| <b>Weight</b>                       | 9.8 kg      |
| <b>Enclosure class</b>              | 44 IP       |
| <b>Wiring diagram</b>               | 4040004     |

### ACCESSORIES

- Mounting clamp MK 250
- Safety grille BSV 250
- Safety grille BSR 250
- Back draught shutter RSK 250
- Louvre YG 250
- Silencer LDC 250
- Transformer controller VRDT 2
- Transformer controller VRTT 2

### SOUND DATA

|                          | $L_{wa}$ tot dB (A) | 63 | 125 | 250 | 500 | 1K | 2K | 4K | 8K |
|--------------------------|---------------------|----|-----|-----|-----|----|----|----|----|
| <b>Surrounding 400 V</b> | 73                  | 50 | 48  | 61  | 63  | 69 | 68 | 65 | 60 |
| <b>Outlet 400 V</b>      | 77                  | 57 | 60  | 68  | 67  | 71 | 70 | 69 | 63 |
| <b>Inlet 400 V</b>       | 76                  | 55 | 59  | 65  | 63  | 72 | 70 | 68 | 63 |

### MORE INFORMATION



Find out the latest updated information about this product by visiting [www.ostberg.com](http://www.ostberg.com) or scanning this QR code.

### DIMENSIONS (mm)

KU

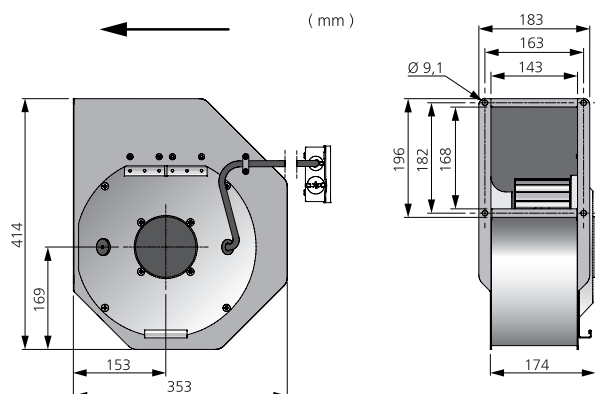

KR

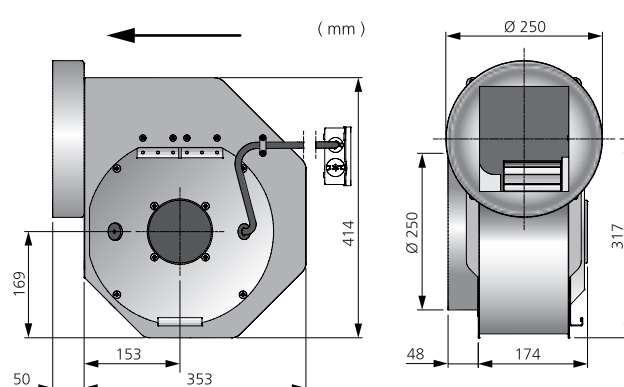

# RADIAL FAN

## RFT 250 B

KU 7720099, UU 7720092, KR 7710100

- 3-phase single inlet radial fan.
- Compact with high capacity and efficiency.
- Low sound levels.
- Impeller with forward curved blades.
- The external rotor motor has maintenance-free sealed ball-bearings.
- The motor is situated in the airstream to get ultimate cooling.
- Integrated motor protection.
- Junction box has enclosure class IP 54.
- For speed control a transformer or electronic speed controller can be connected.
- Fan housing is manufactured from galvanized sheet steel.
- Ideal for use in heat exchangers, dehumidifiers and air cleaners.
- Explanations:  
KR = With junction box, with connection pipes.  
KU = With junction box, without connection pipes.  
UU = Without junction box, without connection pipes.
- All diagrams shown with duct connected fan.



### ACCESSORIES

- Mounting clamp MK 250
- Safety grille BSV 250
- Safety grille BSR 250
- Back draught shutter RSK 250
- Louvre shutter VK 250
- Silencer LDC 250
- Transformer controller VR TT 2
- Transformer controller VR DT 2

### TECHNICAL DATA

|                                     |             |
|-------------------------------------|-------------|
| <b>Voltage</b>                      | 400 V       |
| <b>Frequency</b>                    | 50 Hz       |
| <b>Phase</b>                        | 3 ~         |
| <b>Current</b>                      | 1.4 A       |
| <b>Power</b>                        | 690 W       |
| <b>Speed</b>                        | 1285 r.p.m. |
| <b>Max. temp of transported air</b> | 60 °C       |
| <b>Sound pressure level, 3 m</b>    | 67 dB(A)    |
| <b>Weight</b>                       | 12.6 kg     |
| <b>Enclosure class</b>              | 44 IP       |
| <b>Wiring diagram</b>               | 4040004     |

### PRESSURE/FLOW

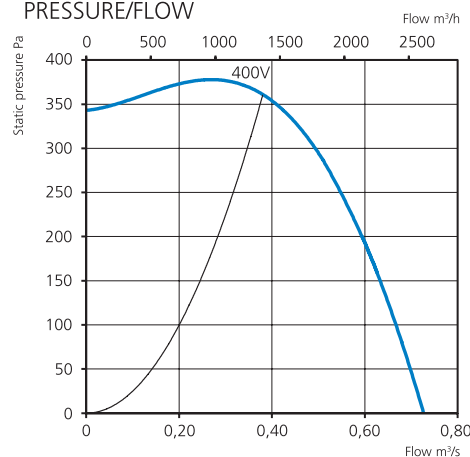

### POWER/FLOW

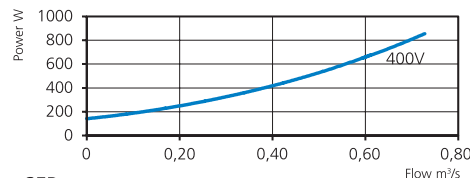

### SFP

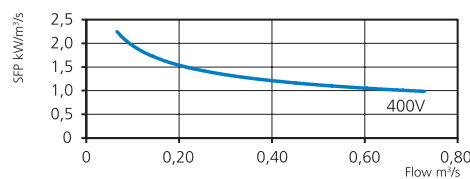

### SOUND DATA

|                          | $L_{wa}$ tot dB (A) | 63 | 125 | 250 | 500 | 1K | 2K | 4K | 8K |
|--------------------------|---------------------|----|-----|-----|-----|----|----|----|----|
| <b>Surrounding 400 V</b> | 74                  | 44 | 50  | 62  | 65  | 69 | 68 | 66 | 59 |
| <b>Outlet 400 V</b>      | 80                  | 63 | 64  | 70  | 72  | 74 | 74 | 74 | 67 |
| <b>Inlet 400 V</b>       | 78                  | 61 | 66  | 68  | 67  | 73 | 70 | 69 | 64 |

### MORE INFORMATION



Find out the latest updated information about this product by visiting [www.ostberg.com](http://www.ostberg.com) or scanning this QR code.

### DIMENSIONS (mm)

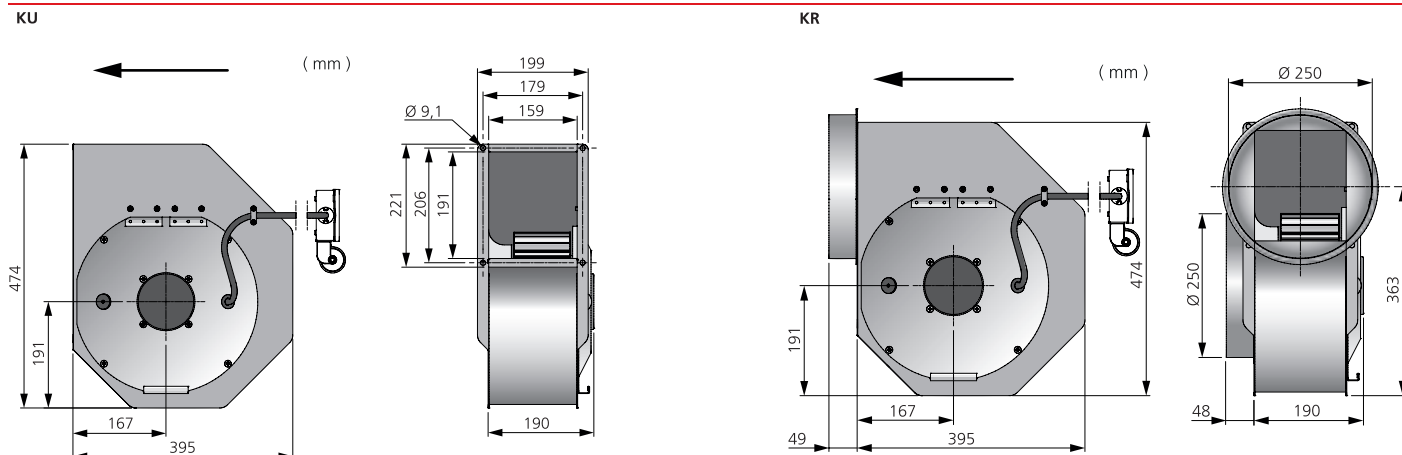

## RFT 280 F

KU 7720041 UU 7720040, KR 7720042



- 3-phase single inlet radial fan.
- Compact with high capacity and efficiency.
- Low sound levels.
- Impeller with forward curved blades.
- The external rotor motor has maintenance-free sealed ball-bearings.
- The motor is situated in the airstream to get ultimate cooling.
- Integrated motor protection.
- Junction box has enclosure class IP 54.
- For speed control a transformer or electronic speed controller can be connected.
- Fan housing is manufactured from galvanized sheet steel.
- Ideal for use in heat exchangers, dehumidifiers and air cleaners.
- Explanations:  
KR = With junction box, with connection pipes.  
KU = With junction box, without connection pipes.  
UU = Without junction box, without connection pipes.
- All diagrams shown with duct connected fan.

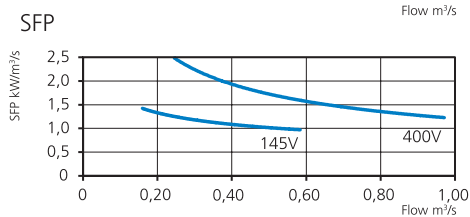
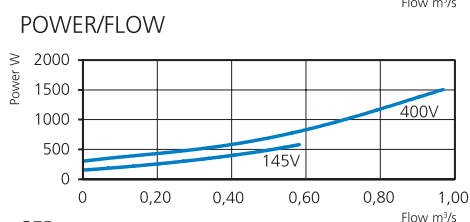
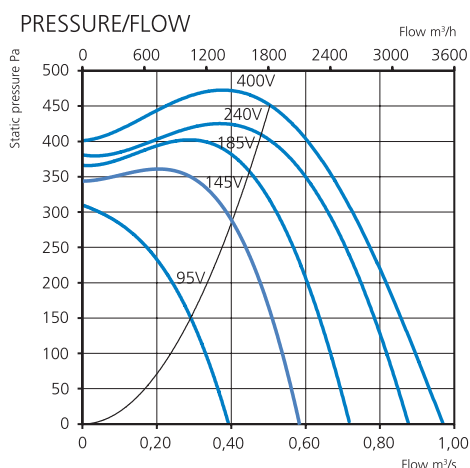

### TECHNICAL DATA

|                                     |             |
|-------------------------------------|-------------|
| <b>Voltage</b>                      | 400 V       |
| <b>Frequency</b>                    | 50 Hz       |
| <b>Phase</b>                        | 3 ~         |
| <b>Current</b>                      | 2.81 A      |
| <b>Power</b>                        | 1496 W      |
| <b>Speed</b>                        | 1400 r.p.m. |
| <b>Max. temp of transported air</b> | 55 °C       |
| <b>Sound pressure level, 3 m</b>    | 72 dB(A)    |
| <b>Weight</b>                       | 21.4 kg     |
| <b>Enclosure class</b>              | 44 IP       |
| <b>Wiring diagram</b>               | 4040004     |

### ACCESSORIES

- Mounting clamp MK 315
- Safety grille BSV 315
- Safety grille BSR 315
- Back draught shutter RSK 315
- Louvre YG 315
- Silencer LDC 315
- Transformer controller VRDT 4
- Transformer controller VRDT 4

### SOUND DATA

|                          | L <sub>wa</sub> tot dB (A) |     |     |     |    |    |    |    |
|--------------------------|----------------------------|-----|-----|-----|----|----|----|----|
|                          | 63                         | 125 | 250 | 500 | 1K | 2K | 4K | 8K |
| <b>Surrounding 400 V</b> | 79                         | 48  | 57  | 65  | 68 | 76 | 74 | 65 |
| <b>Outlet 400 V</b>      | 84                         | 66  | 68  | 74  | 75 | 78 | 77 | 71 |
| <b>Inlet 400 V</b>       | 81                         | 64  | 67  | 69  | 66 | 76 | 74 | 68 |
| <b>Inlet 240 V</b>       | 80                         | 63  | 66  | 68  | 65 | 75 | 73 | 67 |
| <b>Inlet 185 V</b>       | 78                         | 61  | 65  | 67  | 64 | 74 | 72 | 66 |
| <b>Inlet 145 V</b>       | 76                         | 59  | 63  | 65  | 62 | 72 | 70 | 64 |
| <b>Inlet 95 V</b>        | 70                         | 53  | 56  | 58  | 55 | 65 | 63 | 57 |

### MORE INFORMATION



Find out the latest updated information about this product by visiting [www.ostberg.com](http://www.ostberg.com) or scanning this QR code.

### DIMENSIONS (mm)

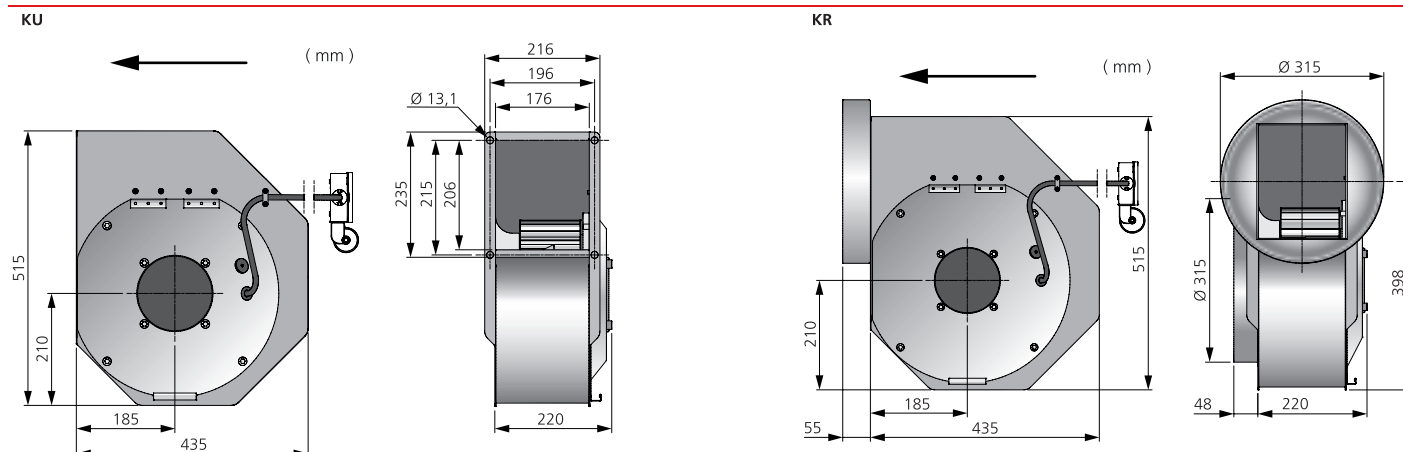

# RADIAL FAN

## RFT 315 E

KU 7720059, UU 7720058, KR 7720060

- 3-phase single inlet radial fan.
- Compact with high capacity and efficiency.
- Low sound levels.
- Impeller with forward curved blades.
- The external rotor motor has maintenance-free sealed ball-bearings.
- The motor is situated in the airstream to get ultimate cooling.
- Integrated motor protection.
- Junction box has enclosure class IP 54.
- For speed control a transformer or electronic speed controller can be connected.
- Fan housing is manufactured from galvanized sheet steel.
- Ideal for use in heat exchangers, dehumidifiers and air cleaners.
- Explanations:  
KR = With junction box, with connection pipes.  
KU = With junction box, without connection pipes.  
UU = Without junction box, without connection pipes.
- All diagrams shown with duct connected fan.



### ACCESSORIES

- Mounting clamp MK 355
- Safety grille BSV 355
- Safety grille BSR 355
- Back draught shutter RSK 355
- Transformer controller VRIT 7
- Transformer controller VRDT 7

### TECHNICAL DATA

|                                     |             |
|-------------------------------------|-------------|
| <b>Voltage</b>                      | 400 V       |
| <b>Frequency</b>                    | 50 Hz       |
| <b>Phase</b>                        | 3 ~         |
| <b>Current</b>                      | 4.1 A       |
| <b>Power</b>                        | 2026 W      |
| <b>Speed</b>                        | 1400 r.p.m. |
| <b>Max. temp of transported air</b> | 50 °C       |
| <b>Sound pressure level, 3 m</b>    | 75 dB(A)    |
| <b>Weight</b>                       | 27 kg       |
| <b>Enclosure class</b>              | 44 IP       |
| <b>Wiring diagram</b>               | 4040004     |

### PRESSURE/FLOW

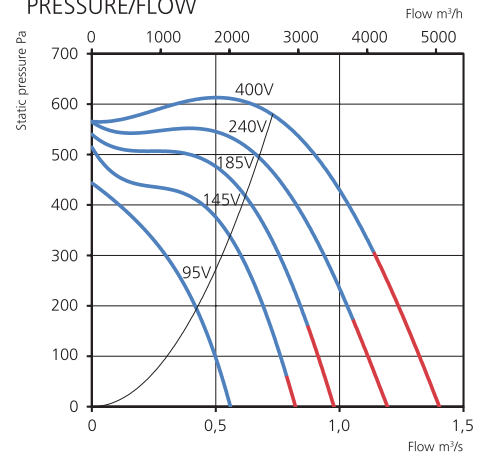

### POWER/FLOW

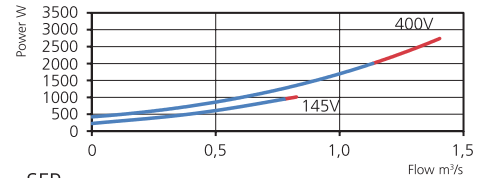

### SFP

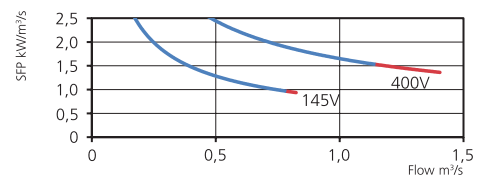

### SOUND DATA

|                          | $L_{wa}$ tot dB (A) | 63 | 125 | 250 | 500 | 1K | 2K | 4K | 8K |
|--------------------------|---------------------|----|-----|-----|-----|----|----|----|----|
| <b>Surrounding 400 V</b> | 82                  | 53 | 61  | 66  | 72  | 79 | 75 | 73 | 66 |
| <b>Outlet 400 V</b>      | 90                  | 74 | 74  | 79  | 81  | 85 | 83 | 81 | 76 |
| <b>Inlet 400 V</b>       | 85                  | 68 | 72  | 73  | 71  | 81 | 79 | 78 | 72 |
| <b>Inlet 240 V</b>       | 83                  | 66 | 70  | 71  | 69  | 79 | 77 | 76 | 71 |
| <b>Inlet 185 V</b>       | 81                  | 64 | 68  | 69  | 67  | 77 | 75 | 74 | 69 |
| <b>Inlet 145 V</b>       | 78                  | 61 | 65  | 66  | 65  | 74 | 72 | 71 | 66 |
| <b>Inlet 95 V</b>        | 71                  | 54 | 58  | 58  | 57  | 66 | 64 | 63 | 58 |

### MORE INFORMATION



Find out the latest updated information about this product by visiting [www.ostberg.com](http://www.ostberg.com) or scanning this QR code.

### DIMENSIONS (mm)

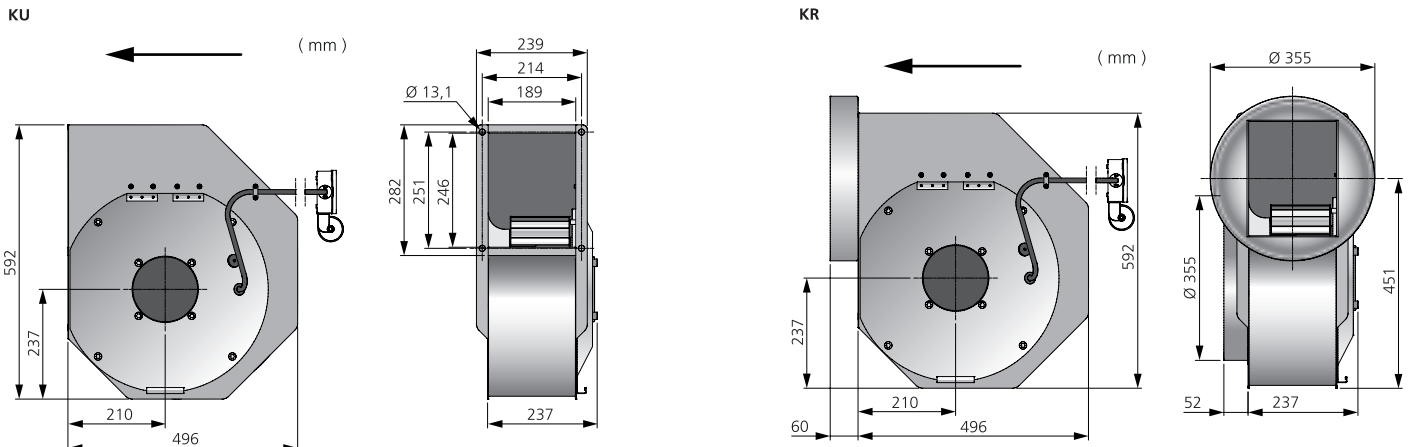



- 3-phase single inlet radial fan.
- Compact with high capacity and efficiency.
- Low sound levels.
- Impeller with forward curved blades.
- The external rotor motor has maintenance-free sealed ball-bearings.
- The motor is situated in the airstream to get ultimate cooling.
- Integrated motor protection.
- Junction box has enclosure class IP 54.
- For speed control a transformer or electronic speed controller can be connected.
- Fan housing is manufactured from galvanized sheet steel.
- Ideal for use in heat exchangers, dehumidifiers and air cleaners.
- Explanations:  
KR = With junction box, with connection pipes.  
KU = With junction box, without connection pipes.  
UU = Without junction box, without connection pipes.
- All diagrams shown with duct connected fan.

PRESSURE/FLOW

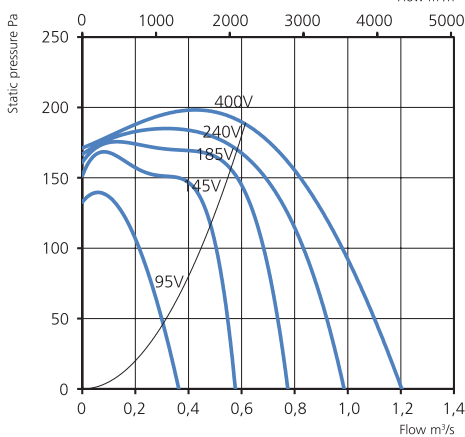

POWER/FLOW

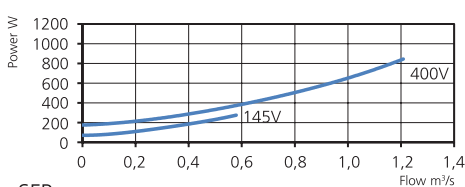

SFP

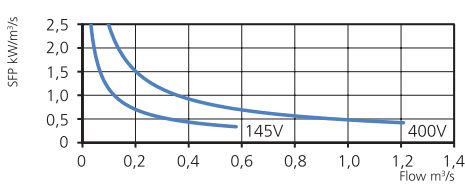

TECHNICAL DATA

|                                     |            |
|-------------------------------------|------------|
| <b>Voltage</b>                      | 400 V      |
| <b>Frequency</b>                    | 50 Hz      |
| <b>Phase</b>                        | 3 ~        |
| <b>Current</b>                      | 2.14 A     |
| <b>Power</b>                        | 954 W      |
| <b>Speed</b>                        | 680 r.p.m. |
| <b>Max. temp of transported air</b> | 80 °C      |
| <b>Sound pressure level, 3 m</b>    | 62 dB(A)   |
| <b>Weight</b>                       | 30.5 kg    |
| <b>Enclosure class</b>              | 44 IP      |
| <b>Wiring diagram</b>               | 4040004    |

ACCESSORIES

- Mounting clamp MK 400
- Safety grille BSV 400
- Safety grille BSR 400
- Back draught shutter RSK 400
- Transformer controller VRIT 4
- Transformer controller VRDT 4

SOUND DATA

|                          | <b>L<sub>wa</sub> tot dB (A)</b> |     |     |     |    |    |    |    |    |
|--------------------------|----------------------------------|-----|-----|-----|----|----|----|----|----|
|                          | 63                               | 125 | 250 | 500 | 1K | 2K | 4K | 8K |    |
| <b>Surrounding 400 V</b> | 69                               | 43  | 52  | 58  | 63 | 64 | 63 | 61 | 51 |
| <b>Outlet 400 V</b>      | 76                               | 55  | 63  | 64  | 67 | 69 | 70 | 68 | 58 |
| <b>Inlet 400 V</b>       | 71                               | 54  | 60  | 58  | 63 | 66 | 65 | 64 | 54 |
| <b>Inlet 240 V</b>       | 70                               | 53  | 59  | 57  | 62 | 65 | 64 | 63 | 53 |
| <b>Inlet 185 V</b>       | 69                               | 52  | 58  | 56  | 61 | 64 | 63 | 62 | 52 |
| <b>Inlet 145 V</b>       | 66                               | 49  | 55  | 53  | 58 | 61 | 60 | 59 | 49 |
| <b>Inlet 95 V</b>        | 33                               | 16  | 22  | 20  | 25 | 28 | 27 | 26 | 16 |

MORE INFORMATION



Find out the latest updated information about this product by visiting [www.ostberg.com](http://www.ostberg.com) or scanning this QR code.

DIMENSIONS (mm)

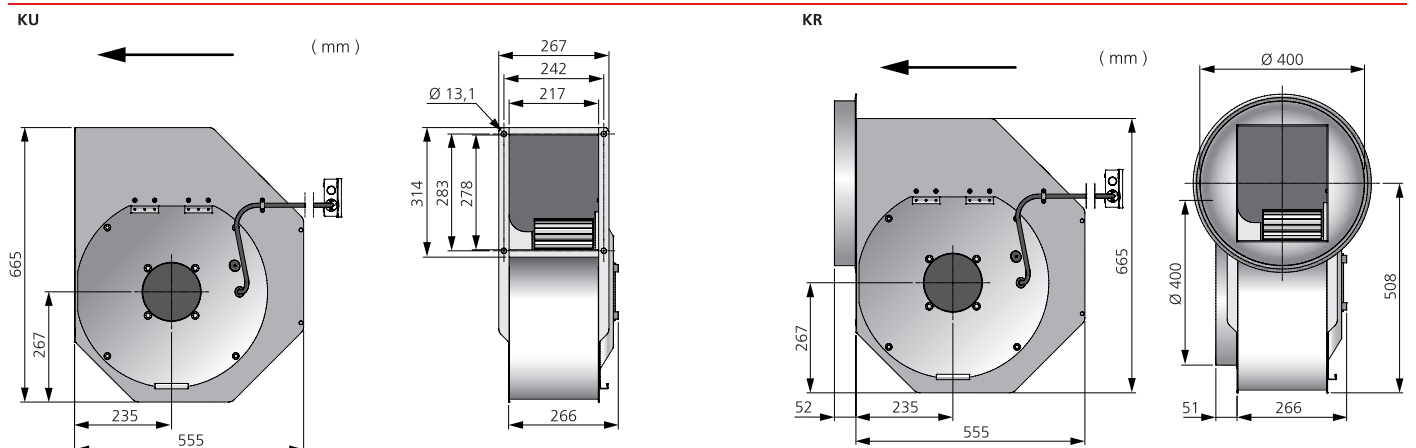

# RADIAL FAN

## RFT 355 B

KU 7720065, UU 7720064, KR 7720066

- 3-phase single inlet radial fan.
- Compact with high capacity and efficiency.
- Low sound levels.
- Impeller with forward curved blades.
- The external rotor motor has maintenance-free sealed ball-bearings.
- The motor is situated in the airstream to get ultimate cooling.
- Integrated motor protection.
- Junction box has enclosure class IP 54.
- For speed control a transformer or electronic speed controller can be connected.
- Fan housing is manufactured from galvanized sheet steel.
- Ideal for use in heat exchangers, dehumidifiers and air cleaners.
- Explanations:  
KR = With junction box, with connection pipes.  
KU = With junction box, without connection pipes.  
UU = Without junction box, without connection pipes.
- All diagrams shown with duct connected fan.



### ACCESSORIES

- Mounting clamp MK 400
- Safety grille BSV 400
- Safety grille BSR 400
- Back draught shutter RSK 400
- Transformer controller VRTT 4
- Transformer controller VRDT 4

### TECHNICAL DATA

|                                     |            |
|-------------------------------------|------------|
| <b>Voltage</b>                      | 400 V      |
| <b>Frequency</b>                    | 50 Hz      |
| <b>Phase</b>                        | 3 ~        |
| <b>Current</b>                      | 2.8 A      |
| <b>Power</b>                        | 1455 W     |
| <b>Speed</b>                        | 764 r.p.m. |
| <b>Max. temp of transported air</b> | 45 °C      |
| <b>Sound pressure level, 3 m</b>    | 67 dB(A)   |
| <b>Weight</b>                       | 30.7 kg    |
| <b>Enclosure class</b>              | 44 IP      |
| <b>Wiring diagram</b>               | 4040004    |

### PRESSURE/FLOW

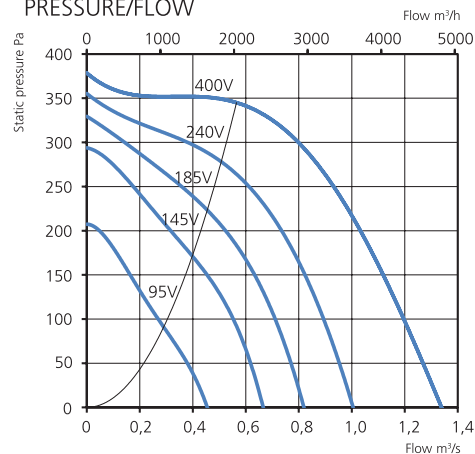

### POWER/FLOW

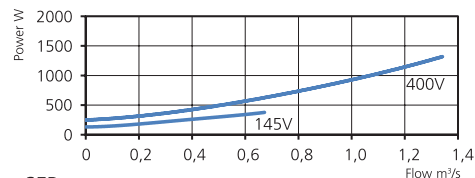

### SFP

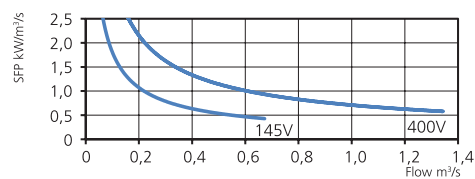

### SOUND DATA

|                          | $L_{WA}$ tot dB (A) | 63 | 125 | 250 | 500 | 1K | 2K | 4K | 8K |
|--------------------------|---------------------|----|-----|-----|-----|----|----|----|----|
| <b>Surrounding 400 V</b> | 74                  | 49 | 57  | 63  | 67  | 69 | 66 | 66 | 57 |
| <b>Outlet 400 V</b>      | 79                  | 58 | 64  | 65  | 69  | 73 | 73 | 73 | 64 |
| <b>Inlet 400 V</b>       | 76                  | 61 | 65  | 62  | 67  | 70 | 70 | 70 | 62 |
| <b>Inlet 240 V</b>       | 74                  | 58 | 62  | 60  | 64  | 67 | 68 | 68 | 60 |
| <b>Inlet 185 V</b>       | 72                  | 56 | 60  | 57  | 62  | 65 | 65 | 66 | 58 |
| <b>Inlet 145 V</b>       | 69                  | 53 | 57  | 55  | 59  | 62 | 63 | 63 | 55 |
| <b>Inlet 95 V</b>        | 59                  | 44 | 48  | 45  | 50  | 53 | 53 | 53 | 45 |

### MORE INFORMATION



Find out the latest updated information about this product by visiting [www.ostberg.com](http://www.ostberg.com) or scanning this QR code.

### DIMENSIONS (mm)

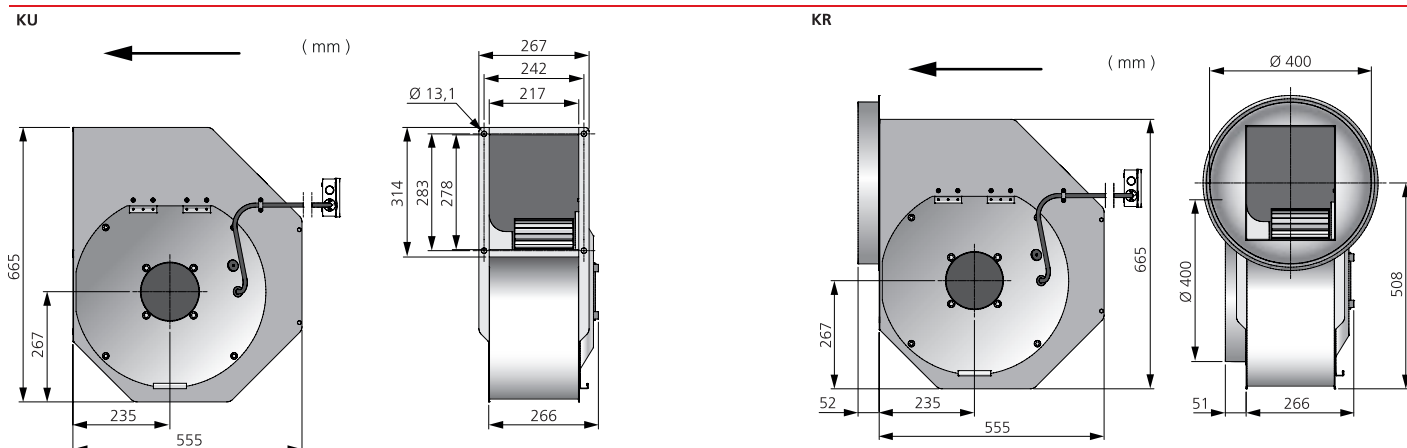



- 3-phase single inlet radial fan.
- Compact with high capacity and efficiency.
- Low sound levels.
- Impeller with forward curved blades.
- The external rotor motor has maintenance-free sealed ball-bearings.
- The motor is situated in the airstream to get ultimate cooling.
- Integrated motor protection.
- Junction box has enclosure class IP 54.
- For speed control a transformer or electronic speed controller can be connected.
- Fan housing is manufactured from galvanized sheet steel.
- Ideal for use in heat exchangers, dehumidifiers and air cleaners.
- Explanations:  
KR = With junction box, with connection pipes.  
KU = With junction box, without connection pipes.  
UU = Without junction box, without connection pipes.
- All diagrams shown with duct connected fan.

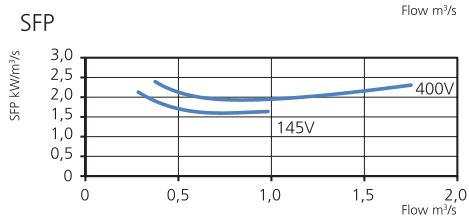
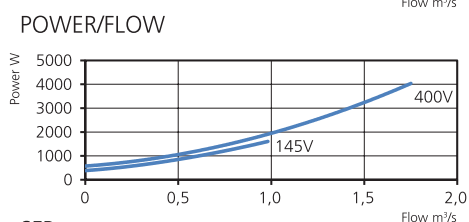
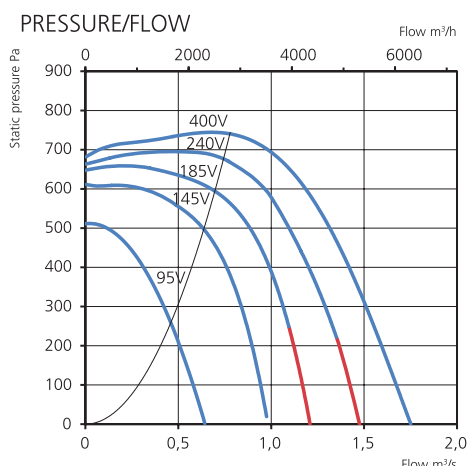

### TECHNICAL DATA

|                                     |             |
|-------------------------------------|-------------|
| <b>Voltage</b>                      | 400 V       |
| <b>Frequency</b>                    | 50 Hz       |
| <b>Phase</b>                        | 3 ~         |
| <b>Current</b>                      | 6.77 A      |
| <b>Power</b>                        | 4048 W      |
| <b>Speed</b>                        | 1371 r.p.m. |
| <b>Max. temp of transported air</b> | 55 °C       |
| <b>Sound pressure level, 3 m</b>    | 78 dB(A)    |
| <b>Weight</b>                       | 40.3 kg     |
| <b>Enclosure class</b>              | 44 IP       |
| <b>Wiring diagram</b>               | 4040004     |

### ACCESSORIES

- Mounting clamp MK 400
- Safety grille BSV 400
- Safety grille BSR 400
- Back draught shutter RSK 400
- Transformer controller VRDT 11
- Transformer controller VRDT 11

### SOUND DATA

|                          | L <sub>wa</sub> tot dB (A) |     |     |     |    |    |    |    |    |
|--------------------------|----------------------------|-----|-----|-----|----|----|----|----|----|
|                          | 63                         | 125 | 250 | 500 | 1K | 2K | 4K | 8K |    |
| <b>Surrounding 400 V</b> | 85                         | 56  | 66  | 70  | 75 | 80 | 79 | 76 | 72 |
| <b>Outlet 400 V</b>      | 91                         | 63  | 74  | 75  | 79 | 86 | 86 | 84 | 78 |
| <b>Inlet 400 V</b>       | 87                         | 67  | 76  | 73  | 76 | 81 | 82 | 79 | 75 |
| <b>Inlet 240 V</b>       | 86                         | 66  | 75  | 72  | 75 | 80 | 81 | 78 | 75 |
| <b>Inlet 185 V</b>       | 85                         | 65  | 73  | 71  | 73 | 79 | 80 | 77 | 73 |
| <b>Inlet 145 V</b>       | 83                         | 63  | 71  | 68  | 71 | 77 | 77 | 75 | 71 |
| <b>Inlet 95 V</b>        | 76                         | 57  | 65  | 62  | 65 | 70 | 71 | 68 | 65 |

### MORE INFORMATION



Find out the latest updated information about this product by visiting [www.ostberg.com](http://www.ostberg.com) or scanning this QR code.

### DIMENSIONS (mm)

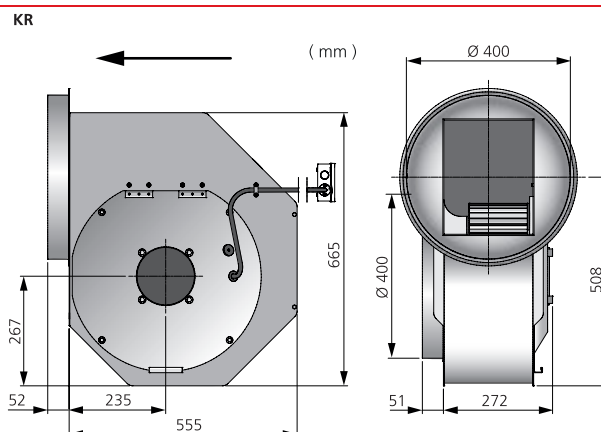
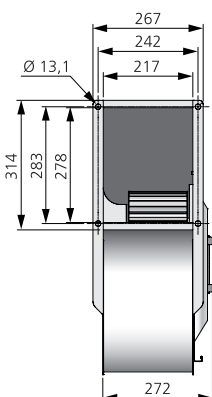
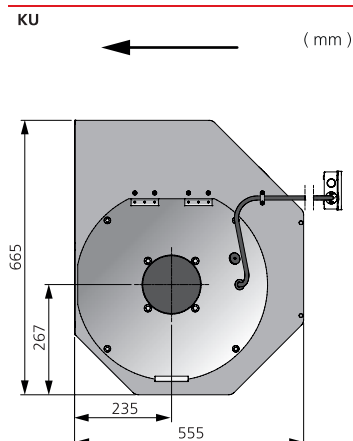

# RADIAL FAN

## RFT 400 C

KU 7720071, UU 7720070, KR 7720072

- 3-phase single inlet radial fan.
- Compact with high capacity and efficiency.
- Low sound levels.
- Impeller with forward curved blades.
- The external rotor motor has maintenance-free sealed ball-bearings.
- The motor is situated in the airstream to get ultimate cooling.
- Integrated motor protection.
- Junction box has enclosure class IP 54.
- For speed control a transformer or electronic speed controller can be connected.
- Fan housing is manufactured from galvanized sheet steel.
- Ideal for use in heat exchangers, dehumidifiers and air cleaners.
- Explanations:  
KR = With junction box, with connection pipes.  
KU = With junction box, without connection pipes.  
UU = Without junction box, without connection pipes.
- All diagrams shown with duct connected fan.



### ACCESSORIES

- Mounting clamp MK 500
- Safety grille BSV 500
- Back draught shutter RSK 500
- Transformer controller VRTT 4
- Transformer controller VRDT 4

### TECHNICAL DATA

|                                     |            |
|-------------------------------------|------------|
| <b>Voltage</b>                      | 400 V      |
| <b>Frequency</b>                    | 50 Hz      |
| <b>Phase</b>                        | 3 ~        |
| <b>Current</b>                      | 2.91 A     |
| <b>Power</b>                        | 1300 W     |
| <b>Speed</b>                        | 645 r.p.m. |
| <b>Max. temp of transported air</b> | 55 °C      |
| <b>Sound pressure level, 3 m</b>    | 70 dB(A)   |
| <b>Weight</b>                       | 41.6 kg    |
| <b>Enclosure class</b>              | 44 IP      |
| <b>Wiring diagram</b>               | 4040004    |

### PRESSURE/FLOW

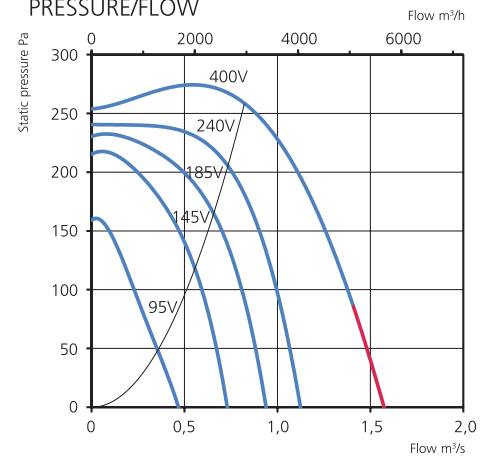

### POWER/FLOW

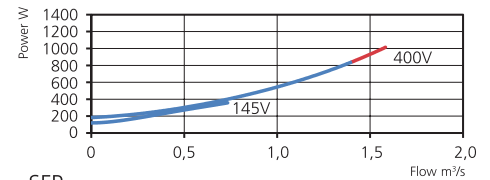

### SFP

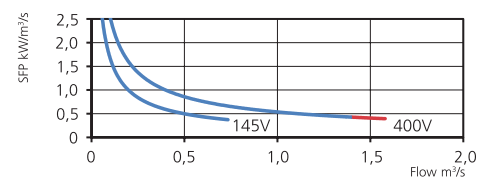

### SOUND DATA

|                          | $L_{WA}$ tot dB (A) | 63 | 125 | 250 | 500 | 1K | 2K | 4K | 8K |
|--------------------------|---------------------|----|-----|-----|-----|----|----|----|----|
| <b>Surrounding 400 V</b> | 77                  | 47 | 58  | 64  | 71  | 72 | 70 | 68 | 62 |
| <b>Outlet 400 V</b>      | 81                  | 59 | 64  | 66  | 74  | 74 | 76 | 73 | 64 |
| <b>Inlet 400 V</b>       | 75                  | 56 | 60  | 59  | 68  | 68 | 69 | 66 | 58 |
| <b>Inlet 240 V</b>       | 72                  | 54 | 58  | 57  | 66  | 66 | 67 | 64 | 56 |
| <b>Inlet 185 V</b>       | 70                  | 51 | 55  | 54  | 63  | 63 | 64 | 61 | 53 |
| <b>Inlet 145 V</b>       | 66                  | 47 | 52  | 50  | 60  | 59 | 61 | 58 | 49 |
| <b>Inlet 95 V</b>        | 46                  | 28 | 32  | 31  | 40  | 40 | 41 | 38 | 30 |

### MORE INFORMATION



Find out the latest updated information about this product by visiting [www.ostberg.com](http://www.ostberg.com) or scanning this QR code.

### DIMENSIONS (mm)

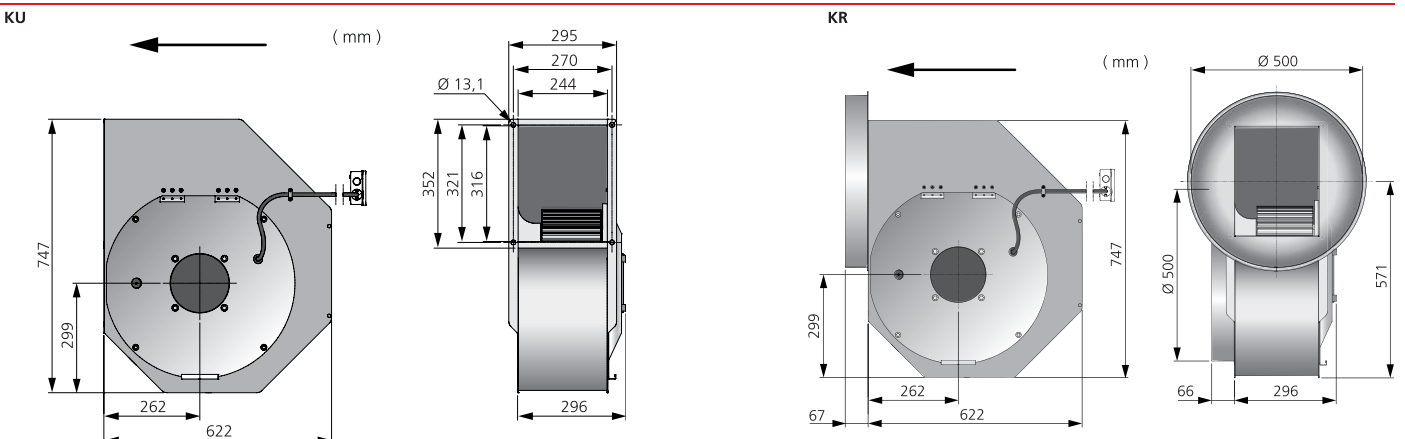



## RFT 400 E

KU 7720074, UU 7720073, KR 7720075



- 3-phase single inlet radial fan.
- Compact with high capacity and efficiency.
- Low sound levels.
- Impeller with forward curved blades.
- The external rotor motor has maintenance-free sealed ball-bearings.
- The motor is situated in the airstream to get ultimate cooling.
- Integrated motor protection.
- Junction box has enclosure class IP 54.
- For speed control a transformer or electronic speed controller can be connected.
- Fan housing is manufactured from galvanized sheet steel.
- Ideal for use in heat exchangers, dehumidifiers and air cleaners.
- Explanations:  
KR = With junction box, with connection pipes.  
KU = With junction box, without connection pipes.  
UU = Without junction box, without connection pipes.
- All diagrams shown with duct connected fan.

### PRESSURE/FLOW

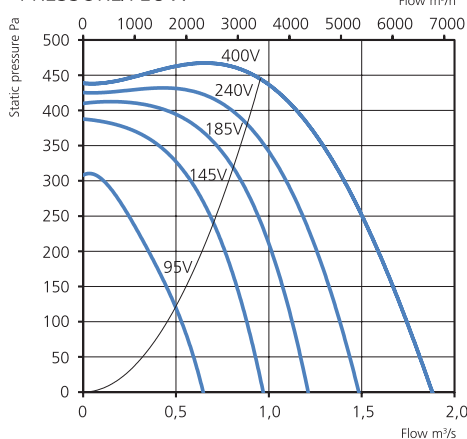

### POWER/FLOW

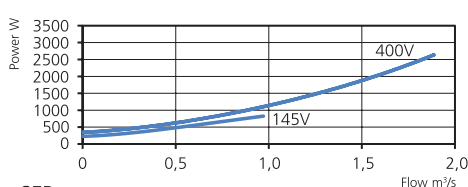

### SFP

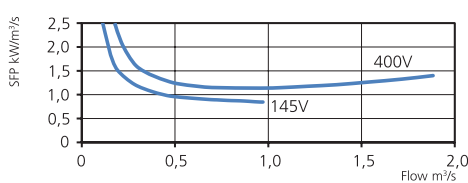

### TECHNICAL DATA

|                                     |            |
|-------------------------------------|------------|
| <b>Voltage</b>                      | 400 V      |
| <b>Frequency</b>                    | 50 Hz      |
| <b>Phase</b>                        | 3 ~        |
| <b>Current</b>                      | 5.74 A     |
| <b>Power</b>                        | 3129 W     |
| <b>Speed</b>                        | 851 r.p.m. |
| <b>Max. temp of transported air</b> | 40 °C      |
| <b>Sound pressure level, 3 m</b>    | 76 dB(A)   |
| <b>Weight</b>                       | 46.1 kg    |
| <b>Enclosure class</b>              | 44 IP      |
| <b>Wiring diagram</b>               | 4040004    |

### ACCESSORIES

- Mounting clamp MK 500
- Safety grille BSV 500
- Back draught shutter RSK 500
- Transformer controller VRIT 7
- Transformer controller VRDT 7

### SOUND DATA

|                          | $L_{WA}$ tot dB (A) | 63 | 125 | 250 | 500 | 1K | 2K | 4K | 8K |
|--------------------------|---------------------|----|-----|-----|-----|----|----|----|----|
| <b>Surrounding 400 V</b> | 83                  | 55 | 63  | 68  | 76  | 78 | 77 | 74 | 69 |
| <b>Outlet 400 V</b>      | 87                  | 64 | 69  | 70  | 79  | 81 | 82 | 80 | 72 |
| <b>Inlet 400 V</b>       | 82                  | 62 | 68  | 64  | 73  | 76 | 77 | 75 | 68 |
| <b>Inlet 240 V</b>       | 80                  | 60 | 66  | 62  | 72  | 74 | 75 | 73 | 66 |
| <b>Inlet 185 V</b>       | 78                  | 58 | 64  | 60  | 70  | 72 | 73 | 71 | 64 |
| <b>Inlet 145 V</b>       | 75                  | 56 | 61  | 58  | 67  | 69 | 70 | 68 | 62 |
| <b>Inlet 95 V</b>        | 64                  | 45 | 50  | 47  | 56  | 58 | 59 | 57 | 51 |

### MORE INFORMATION



Find out the latest updated information about this product by visiting [www.ostberg.com](http://www.ostberg.com) or scanning this QR code.

### DIMENSIONS (mm)

KU

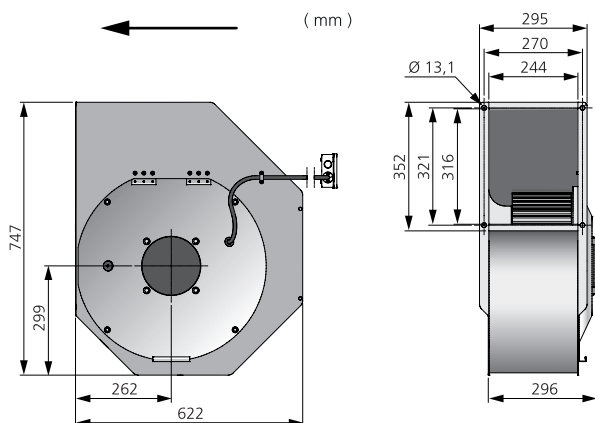

KR

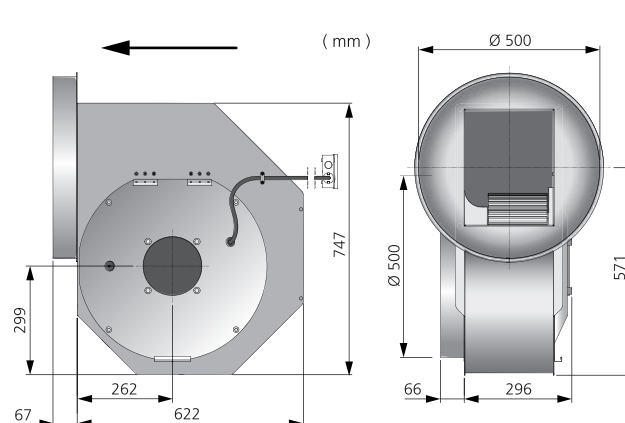

# RADIAL FAN

## RFT 400 F

KU 7720077, UU 7720076, KR 7720078

- 3-phase single inlet radial fan.
- Compact with high capacity and efficiency.
- Low sound levels.
- Impeller with forward curved blades.
- The external rotor motor has maintenance-free sealed ball-bearings.
- The motor is situated in the airstream to get ultimate cooling.
- Integrated motor protection.
- Junction box has enclosure class IP 54.
- For speed control a transformer or electronic speed controller can be connected.
- Fan housing is manufactured from galvanized sheet steel.
- Ideal for use in heat exchangers, dehumidifiers and air cleaners.
- Explanations:  
KR = With junction box, with connection pipes.  
KU = With junction box, without connection pipes.  
UU = Without junction box, without connection pipes.
- All diagrams shown with duct connected fan.



### ACCESSORIES

- Mounting clamp MK 500
- Safety grille BSV 500
- Back draught shutter RSK 500
- Transformer controller VRTT 11
- Transformer controller VRDT 11

### TECHNICAL DATA

|                                     |             |
|-------------------------------------|-------------|
| <b>Voltage</b>                      | 400 V       |
| <b>Frequency</b>                    | 50 Hz       |
| <b>Phase</b>                        | 3 ~         |
| <b>Current</b>                      | 9.69 A      |
| <b>Power</b>                        | 5843 W      |
| <b>Speed</b>                        | 1374 r.p.m. |
| <b>Max. temp of transported air</b> | 40 °C       |
| <b>Sound pressure level, 3 m</b>    | 80 dB(A)    |
| <b>Weight</b>                       | 55.2 kg     |
| <b>Enclosure class</b>              | 44 IP       |
| <b>Wiring diagram</b>               | 4040004     |

### PRESSURE/FLOW

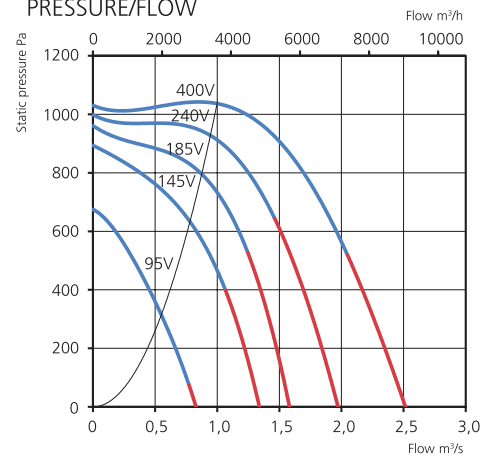

### SOUND DATA

|                          | $L_{WA}$ tot dB (A) | 63 | 125 | 250 | 500 | 1K | 2K | 4K | 8K |
|--------------------------|---------------------|----|-----|-----|-----|----|----|----|----|
| <b>Surrounding 400 V</b> | 87                  | 64 | 70  | 71  | 78  | 83 | 81 | 78 | 73 |
| <b>Outlet 400 V</b>      | 95                  | 67 | 76  | 77  | 85  | 90 | 90 | 87 | 81 |
| <b>Inlet 400 V</b>       | 91                  | 71 | 73  | 74  | 80  | 85 | 86 | 83 | 79 |
| <b>Inlet 240 V</b>       | 89                  | 69 | 71  | 72  | 79  | 84 | 84 | 81 | 77 |
| <b>Inlet 185 V</b>       | 87                  | 67 | 69  | 70  | 77  | 81 | 82 | 79 | 75 |
| <b>Inlet 145 V</b>       | 84                  | 65 | 67  | 67  | 74  | 79 | 79 | 76 | 73 |
| <b>Inlet 95 V</b>        | 75                  | 56 | 58  | 58  | 65  | 70 | 70 | 68 | 64 |

### POWER/FLOW

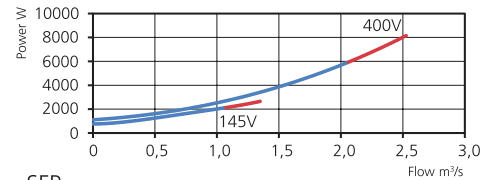

### SFP

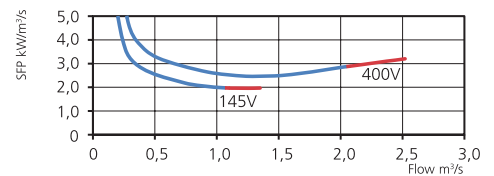

### MORE INFORMATION



Find out the latest updated information about this product by visiting [www.ostberg.com](http://www.ostberg.com) or scanning this QR code.

### DIMENSIONS (mm)

KU

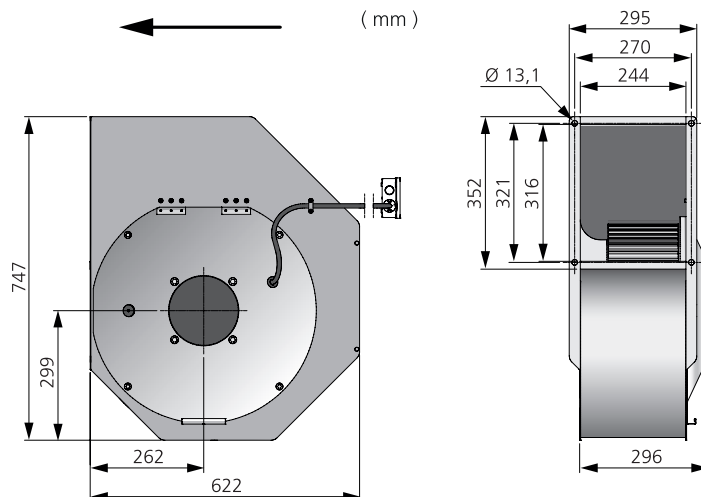



- 3-phase single inlet radial fan.
- Compact with high capacity and efficiency.
- Low sound levels.
- Impeller with forward curved blades.
- The external rotor motor has maintenance-free sealed ball-bearings.
- The motor is situated in the airstream to get ultimate cooling.
- Integrated motor protection.
- Junction box has enclosure class IP 54.
- For speed control a transformer or electronic speed controller can be connected.
- Fan housing is manufactured from galvanized sheet steel.
- Ideal for use in heat exchangers, dehumidifiers and air cleaners.
- Explanations:  
KR = With junction box, with connection pipes.  
KU = With junction box, without connection pipes.  
UU = Without junction box, without connection pipes.
- All diagrams shown with duct connected fan.

### PRESSURE/FLOW

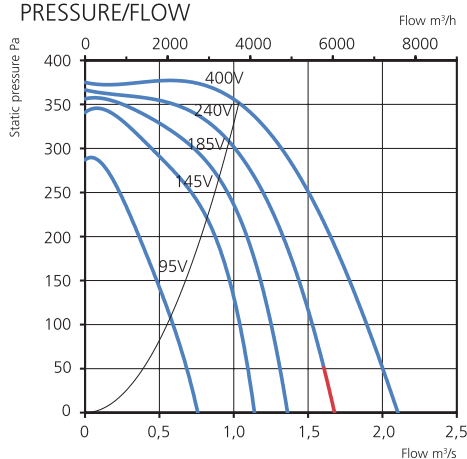

### POWER/FLOW

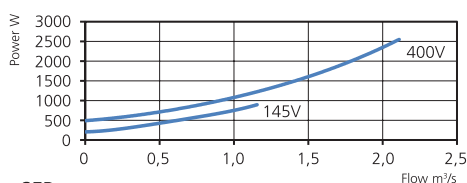

### SFP

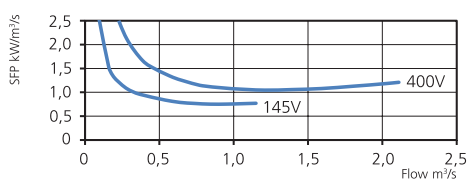

### TECHNICAL DATA

|                                     |            |
|-------------------------------------|------------|
| <b>Voltage</b>                      | 400 V      |
| <b>Frequency</b>                    | 50 Hz      |
| <b>Phase</b>                        | 3 ~        |
| <b>Current</b>                      | 5.42 A     |
| <b>Power</b>                        | 2829 W     |
| <b>Speed</b>                        | 665 r.p.m. |
| <b>Max. temp of transported air</b> | 40 °C      |
| <b>Sound pressure level, 3 m</b>    | 71 dB(A)   |
| <b>Weight</b>                       | 57.2 kg    |
| <b>Enclosure class</b>              | 44 IP      |
| <b>Wiring diagram</b>               | 4040004    |

### ACCESSORIES

- Mounting clamp MK 500
- Safety grille BSV 500
- Back draught shutter RSK 500
- Transformer controller VRDT 7
- Transformer controller VRDT 7

### SOUND DATA

|                          | $L_{WA}$ tot dB (A) | 63 | 125 | 250 | 500 | 1K | 2K | 4K | 8K |
|--------------------------|---------------------|----|-----|-----|-----|----|----|----|----|
| <b>Surrounding 400 V</b> | 78                  | 49 | 57  | 63  | 75  | 72 | 70 | 68 | 60 |
| <b>Outlet 400 V</b>      | 85                  | 65 | 69  | 72  | 78  | 79 | 80 | 76 | 68 |
| <b>Inlet 400 V</b>       | 79                  | 61 | 64  | 62  | 70  | 72 | 75 | 71 | 64 |
| <b>Inlet 240 V</b>       | 77                  | 60 | 59  | 60  | 69  | 70 | 73 | 70 | 62 |
| <b>Inlet 185 V</b>       | 76                  | 58 | 58  | 59  | 67  | 68 | 72 | 68 | 61 |
| <b>Inlet 145 V</b>       | 74                  | 57 | 56  | 57  | 66  | 67 | 70 | 67 | 59 |
| <b>Inlet 95 V</b>        | 55                  | 38 | 37  | 38  | 47  | 48 | 51 | 48 | 40 |

### MORE INFORMATION



Find out the latest updated information about this product by visiting [www.ostberg.com](http://www.ostberg.com) or scanning this QR code.

### DIMENSIONS (mm)

KU

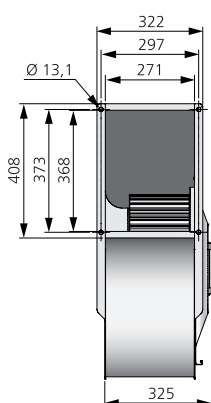
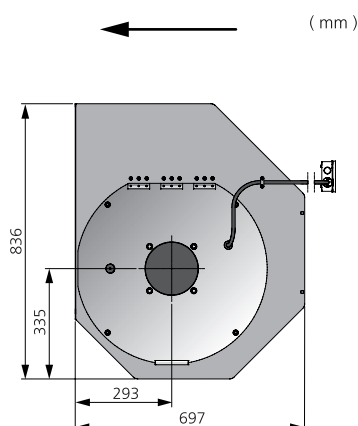

KR

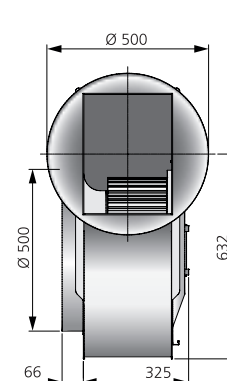
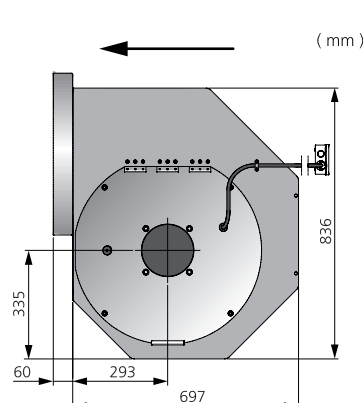

# RADIAL FAN

## RFT 450 H

KU 7720083 , UU 7720082, KR 7720084

- 3-phase single inlet radial fan.
- Compact with high capacity and efficiency.
- Low sound levels.
- Impeller with forward curved blades.
- The external rotor motor has maintenance-free sealed ball-bearings.
- The motor is situated in the airstream to get ultimate cooling.
- Integrated motor protection.
- Junction box has enclosure class IP 54.
- For speed control a transformer or electronic speed controller can be connected.
- Fan housing is manufactured from galvanized sheet steel.
- Ideal for use in heat exchangers, dehumidifiers and air cleaners.
- Explanations:  
KR = With junction box, with connection pipes.  
KU = With junction box, without connection pipes.  
UU = Without junction box, without connection pipes.
- All diagrams shown with duct connected fan.



### ACCESSORIES

- Mounting clamp MK 500
- Safety grille BSV 500
- Back draught shutter RSK 500
- Transformer controller VRTT 11
- Transformer controller VRDT 11

### TECHNICAL DATA

|                                     |            |
|-------------------------------------|------------|
| <b>Voltage</b>                      | 400 V      |
| <b>Frequency</b>                    | 50 Hz      |
| <b>Phase</b>                        | 3 ~        |
| <b>Current</b>                      | 7.04 A     |
| <b>Power</b>                        | 3795 W     |
| <b>Speed</b>                        | 865 r.p.m. |
| <b>Max. temp of transported air</b> | 45 °C      |
| <b>Sound pressure level, 3 m</b>    | 75 dB(A)   |
| <b>Weight</b>                       | 57.8 kg    |
| <b>Enclosure class</b>              | 44 IP      |
| <b>Wiring diagram</b>               | 4040004    |

### PRESSURE/FLOW

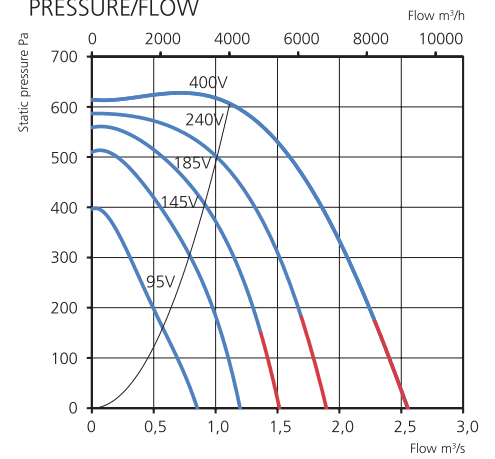

### POWER/FLOW

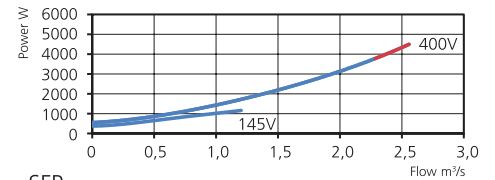

### SFP

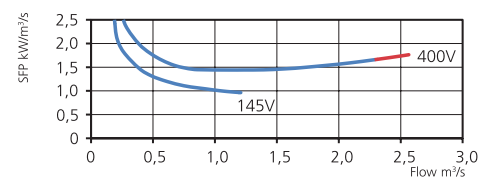

### SOUND DATA

|                          | L <sub>WA</sub> tot dB (A) | 63 | 125 | 250 | 500 | 1K | 2K | 4K | 8K |
|--------------------------|----------------------------|----|-----|-----|-----|----|----|----|----|
| <b>Surrounding 400 V</b> | 82                         | 55 | 65  | 68  | 77  | 77 | 75 | 73 | 67 |
| <b>Outlet 400 V</b>      | 88                         | 68 | 73  | 73  | 80  | 82 | 83 | 79 | 71 |
| <b>Inlet 400 V</b>       | 84                         | 67 | 71  | 66  | 74  | 77 | 79 | 76 | 69 |
| <b>Inlet 240 V</b>       | 82                         | 66 | 69  | 64  | 72  | 75 | 77 | 74 | 68 |
| <b>Inlet 185 V</b>       | 79                         | 63 | 67  | 62  | 69  | 73 | 75 | 71 | 65 |
| <b>Inlet 145 V</b>       | 77                         | 60 | 64  | 59  | 67  | 70 | 72 | 69 | 62 |
| <b>Inlet 95 V</b>        | 67                         | 51 | 55  | 50  | 57  | 61 | 63 | 59 | 53 |

### MORE INFORMATION



Find out the latest updated information about this product by visiting [www.ostberg.com](http://www.ostberg.com) or scanning this QR code.

### DIMENSIONS (mm)

KU

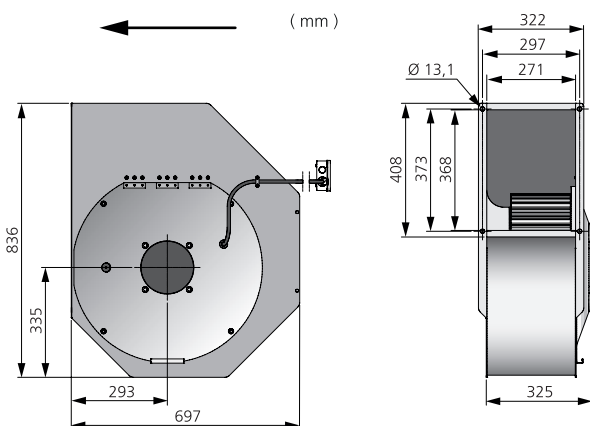

KR

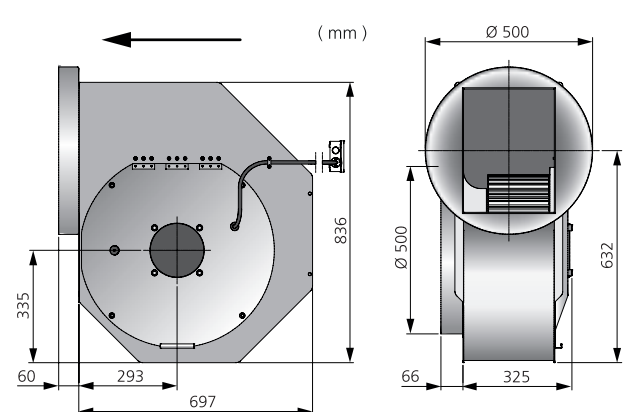

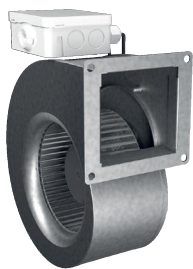

- Single-phase single inlet radial fan.
- Compact with high capacity and efficiency.
- Low sound levels.
- Impeller with forward curved blades.
- The external rotor motor has maintenance-free sealed ball-bearings.
- The motor is situated in the airstream to get ultimate cooling.
- Integrated motor protection.
- Junction box has enclosure class IP 54.
- Speed controlling can be done with the built-in potentiometer, 0-10 V alt. external control.
- Fan housing is manufactured from galvanized sheet steel.
- Ideal for use in heat exchangers, dehumidifiers and air cleaners.
- Can be ordered as:  
KU = With junction box, without connection pipes.  
UU = Without junction box, without connection pipes.
- All diagrams shown with duct connected fan.

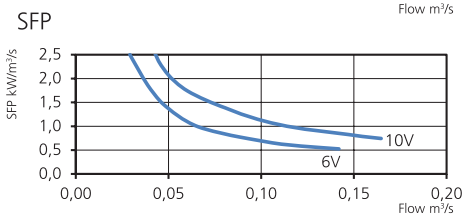
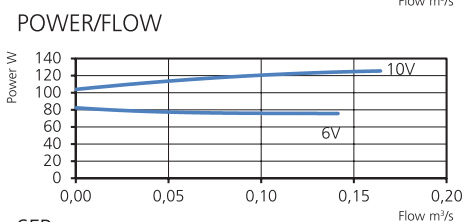
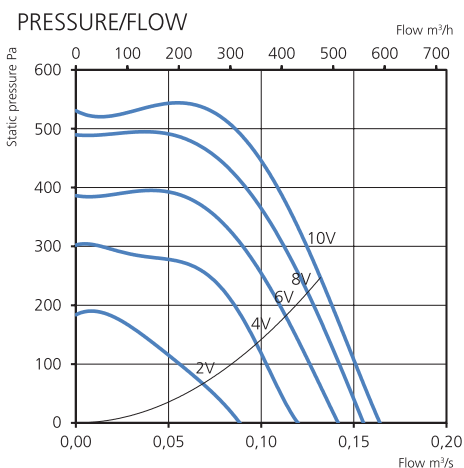

### TECHNICAL DATA

|                                     |             |
|-------------------------------------|-------------|
| <b>Voltage</b>                      | 230 V       |
| <b>Frequency</b>                    | 50/60 Hz    |
| <b>Phase</b>                        | 1 ~         |
| <b>Current</b>                      | 1.01 A      |
| <b>Power</b>                        | 126 W       |
| <b>Speed</b>                        | 2030 r.p.m. |
| <b>Max. temp of transported air</b> | 60 °C       |
| <b>Sound pressure level, 3 m</b>    | 45 dB(A)    |
| <b>Weight</b>                       | 2.8 kg      |
| <b>Enclosure class</b>              | 44 IP       |
| <b>Wiring diagram</b>               | 4040153     |

### ACCESSORIES

- Speed controller MS EC
- Controller IQ-Reg EC
- Pressure regulator CALAIR-PR-230V
- Pressure regulator FKP-R

### SOUND DATA

|                         | L <sub>WA</sub> tot dB (A) | 63 | 125 | 250 | 500 | 1K | 2K | 4K | 8K |
|-------------------------|----------------------------|----|-----|-----|-----|----|----|----|----|
| <b>Surrounding 10 V</b> | 52                         | 20 | 24  | 39  | 50  | 39 | 43 | 40 | 37 |
| <b>Outlet 10 V</b>      | 79                         | 63 | 74  | 70  | 71  | 69 | 71 | 70 | 69 |
| <b>Inlet 10 V</b>       | 75                         | 63 | 69  | 67  | 68  | 64 | 68 | 65 | 64 |
| <b>Inlet 8 V</b>        | 74                         | 62 | 67  | 66  | 66  | 63 | 66 | 64 | 62 |
| <b>Inlet 6 V</b>        | 72                         | 60 | 65  | 64  | 65  | 61 | 64 | 61 | 59 |
| <b>Inlet 4 V</b>        | 68                         | 57 | 61  | 60  | 60  | 59 | 61 | 58 | 56 |
| <b>Inlet 2 V</b>        | 61                         | 50 | 54  | 53  | 54  | 53 | 53 | 49 | 43 |

### MORE INFORMATION



Find out the latest updated information about this product by visiting [www.ostberg.com](http://www.ostberg.com) or scanning this QR code.

### DIMENSIONS (mm)

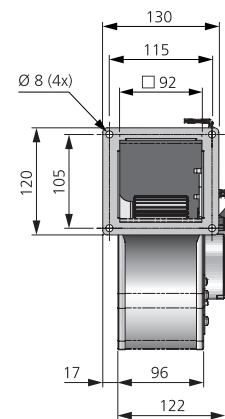
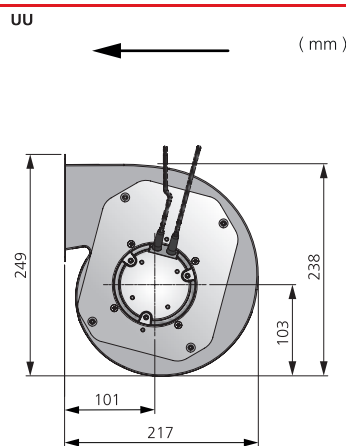
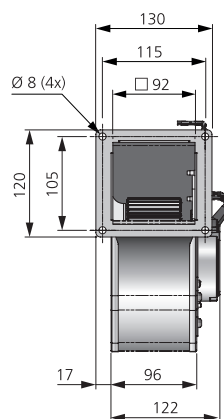
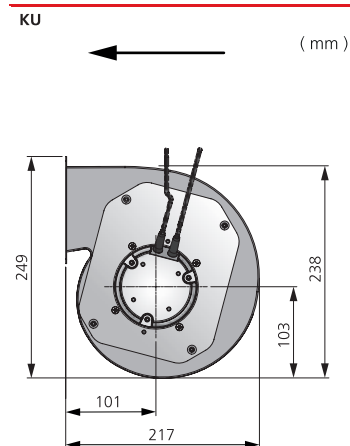

# RADIAL FAN

## RFE 146 D EC

KU 7720260 , UU 7720261

- Single-phase single inlet radial fan.
- Compact with high capacity and efficiency.
- Low sound levels.
- Impeller with forward curved blades.
- The external rotor motor has maintenance-free sealed ball-bearings.
- The motor is situated in the airstream to get ultimate cooling.
- Integrated motor protection.
- Junction box has enclosure class IP 54.
- Speed controlling can be done with the built-in potentiometer, 0-10 V alt. external control.
- Fan housing is manufactured from galvanized sheet steel.
- Ideal for use in heat exchangers, dehumidifiers and air cleaners.
- Can be ordered as:  
KU = With junction box, without connection pipes.  
UU = Without junction box, without connection pipes.
- All diagrams shown with duct connected fan.



### ACCESSORIES

- Speed controller MS EC
- Controller IQ-Reg EC
- Pressure regulator CALAIR-PR-230V
- Pressure regulator FKP-R

### TECHNICAL DATA

|                                     |             |
|-------------------------------------|-------------|
| <b>Voltage</b>                      | 230 V       |
| <b>Frequency</b>                    | 50/60 Hz    |
| <b>Phase</b>                        | 1 ~         |
| <b>Current</b>                      | 0.99 A      |
| <b>Power</b>                        | 131 W       |
| <b>Speed</b>                        | 3300 r.p.m. |
| <b>Max. temp of transported air</b> | 60 °C       |
| <b>Sound pressure level, 3 m</b>    | 45 dB(A)    |
| <b>Weight</b>                       | 2.7 kg      |
| <b>Enclosure class</b>              | 54 IP       |
| <b>Wiring diagram</b>               | 4040180     |

### PRESSURE/FLOW

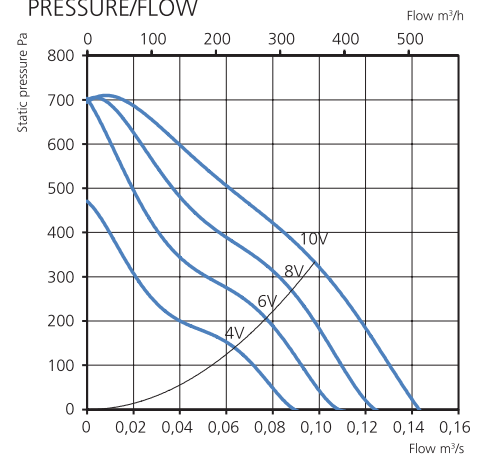

### POWER/FLOW

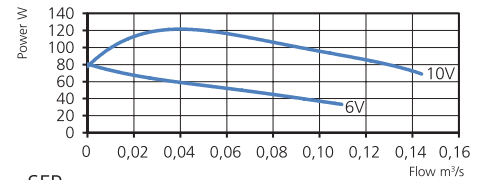

### SFP

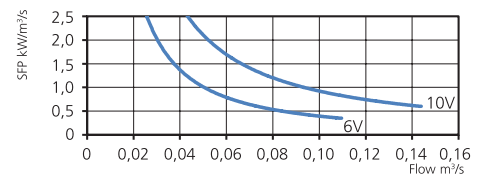

### SOUND DATA

|                         | $L_{wa}$ tot dB (A) | 63 | 125 | 250 | 500 | 1K | 2K | 4K | 8K |
|-------------------------|---------------------|----|-----|-----|-----|----|----|----|----|
| <b>Surrounding 10 V</b> | 52                  | 21 | 26  | 39  | 50  | 42 | 43 | 41 | 36 |
| <b>Outlet 10 V</b>      | 74                  | 60 | 66  | 66  | 66  | 65 | 66 | 64 | 64 |
| <b>Inlet 10 V</b>       | 73                  | 58 | 65  | 67  | 68  | 60 | 65 | 62 | 59 |
| <b>Inlet 8 V</b>        | 72                  | 56 | 65  | 66  | 67  | 58 | 63 | 60 | 56 |
| <b>Inlet 6 V</b>        | 69                  | 51 | 61  | 63  | 63  | 56 | 60 | 57 | 51 |
| <b>Inlet 4 V</b>        | 65                  | 48 | 60  | 59  | 58  | 53 | 55 | 51 | 43 |

### MORE INFORMATION



Find out the latest updated information about this product by visiting [www.ostberg.com](http://www.ostberg.com) or scanning this QR code.

### DIMENSIONS (mm)

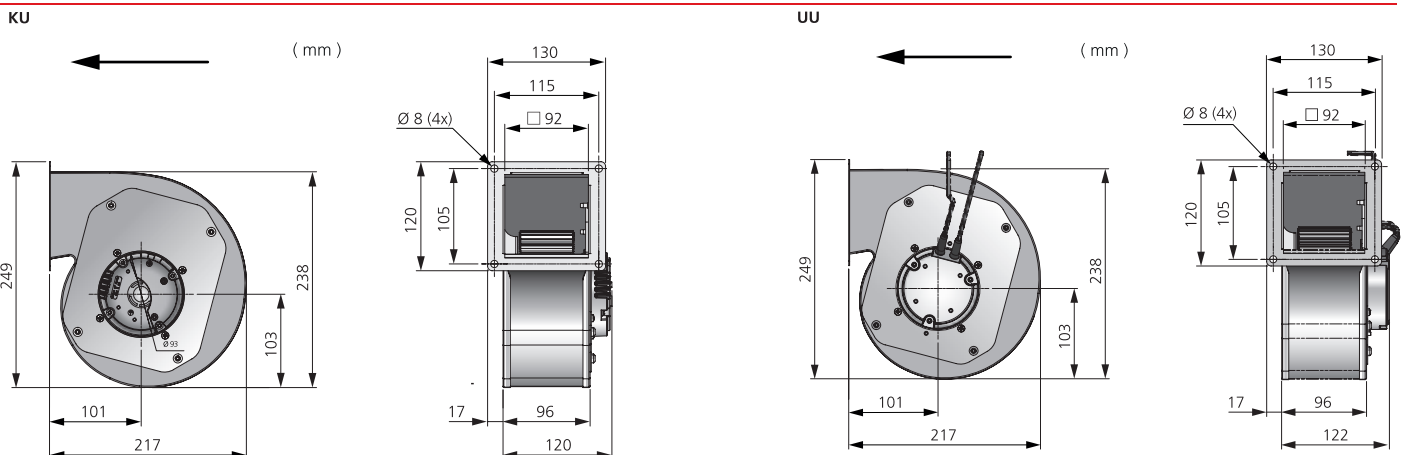

# RBE 190 C EC

KU 7710319, UU 7710315



- Single-phase single inlet radial fan.
- Compact with high capacity and efficiency.
- Low sound levels.
- Impeller with backward curved blades.
- The external rotor motor has maintenance-free sealed ball-bearings.
- The motor is situated in the airstream to get ultimate cooling.
- Integrated motor protection.
- Junction box has enclosure class IP 54.
- Speed controlling can be done with the built-in potentiometer, 0-10 V alt. external control.
- Fan housing is manufactured from galvanized sheet steel.
- Ideal for use in heat exchangers, dehumidifiers and air cleaners.
- Explanations:  
KU = With junction box, without connection pipes.  
UU = Without junction box, without connection pipes.
- All diagrams shown with duct connected fan.

## PRESSURE/FLOW

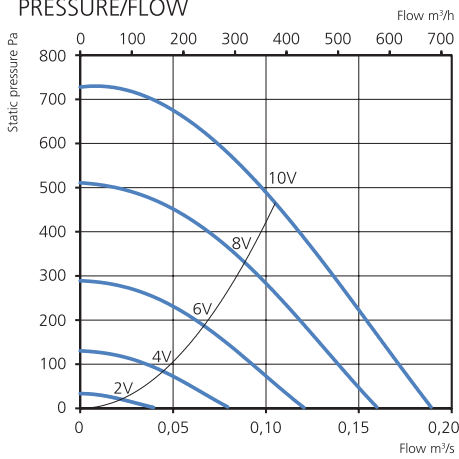

## POWER/FLOW

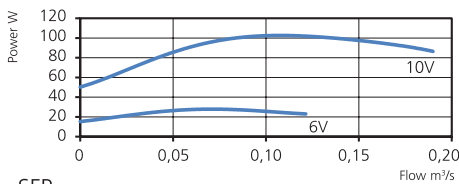

## SFP

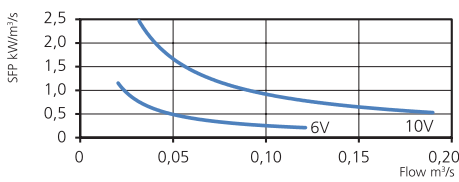

## TECHNICAL DATA

|                                     |             |
|-------------------------------------|-------------|
| <b>Voltage</b>                      | 230 V       |
| <b>Frequency</b>                    | 50/60 Hz    |
| <b>Phase</b>                        | 1 ~         |
| <b>Current</b>                      | 0.84 A      |
| <b>Power</b>                        | 102 W       |
| <b>Speed</b>                        | 3590 r.p.m. |
| <b>Max. temp of transported air</b> | 60 °C       |
| <b>Sound pressure level, 3 m</b>    | 52 dB(A)    |
| <b>Weight</b>                       | 3.7 kg      |
| <b>Enclosure class</b>              | 44 IP       |
| <b>Wiring diagram</b>               | 4040153     |

## ACCESSORIES

- Speed controller MS EC
- Controller IQ-Reg EC

## SOUND DATA

|                         | $L_{wa}$ tot dB (A) | 63 | 125 | 250 | 500 | 1K | 2K | 4K | 8K |
|-------------------------|---------------------|----|-----|-----|-----|----|----|----|----|
| <b>Surrounding 10 V</b> | 59                  | 35 | 42  | 49  | 54  | 52 | 54 | 50 | 39 |
| <b>Outlet 10 V</b>      | 80                  | 59 | 67  | 69  | 77  | 72 | 72 | 68 | 64 |
| <b>Inlet 10 V</b>       | 77                  | 58 | 69  | 71  | 72  | 68 | 66 | 64 | 60 |
| <b>Inlet 8 V</b>        | 74                  | 57 | 68  | 68  | 69  | 63 | 62 | 61 | 54 |
| <b>Inlet 6 V</b>        | 67                  | 53 | 60  | 62  | 60  | 56 | 55 | 53 | 43 |
| <b>Inlet 4 V</b>        | 57                  | 45 | 52  | 51  | 51  | 48 | 46 | 39 | 27 |
| <b>Inlet 2 V</b>        | 40                  | 32 | 34  | 32  | 35  | 28 | 21 | 15 | 8  |

## MORE INFORMATION



Find out the latest updated information about this product by visiting [www.ostberg.com](http://www.ostberg.com) or scanning this QR code.

## DIMENSIONS (mm)

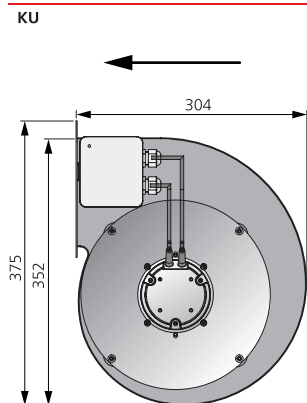

(mm)

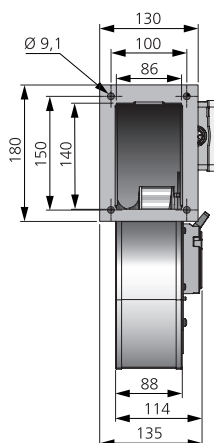

UU

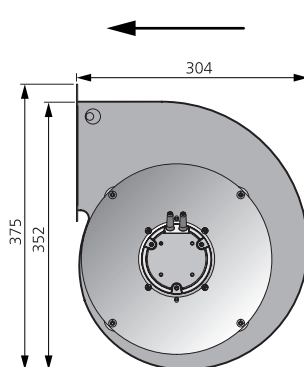

(mm)

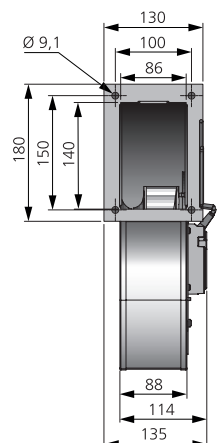

# RADIAL FAN

## RBE 220 C EC

KU 7710322 , UU 7710321

- Single-phase single inlet radial fan.
- Compact with high capacity and efficiency.
- Low sound levels.
- Impeller with backward curved blades.
- The external rotor motor has maintenance-free sealed ball-bearings.
- The motor is situated in the airstream to get ultimate cooling.
- Integrated motor protection.
- Junction box has enclosure class IP 54.
- Speed controlling can be done with the built-in potentiometer, 0-10 V alt. external control.
- Fan housing is manufactured from galvanized sheet steel.
- Ideal for use in heat exchangers, dehumidifiers and air cleaners.
- Explanations:  
KU = With junction box, without connection pipes.  
UU = Without junction box, without connection pipes.
- All diagrams shown with duct connected fan.



### ACCESSORIES

- Speed controller MS EC
- Controller IQ-Reg EC

### TECHNICAL DATA

|                                     |             |
|-------------------------------------|-------------|
| <b>Voltage</b>                      | 230 V       |
| <b>Frequency</b>                    | 50/60 Hz    |
| <b>Phase</b>                        | 1 ~         |
| <b>Current</b>                      | 1.00 A      |
| <b>Power</b>                        | 124 W       |
| <b>Speed</b>                        | 2890 r.p.m. |
| <b>Max. temp of transported air</b> | 60 °C       |
| <b>Sound pressure level, 3 m</b>    | 51 dB(A)    |
| <b>Weight</b>                       | 5.1 kg      |
| <b>Enclosure class</b>              | 44 IP       |
| <b>Wiring diagram</b>               | 4040153     |

### PRESSURE/FLOW

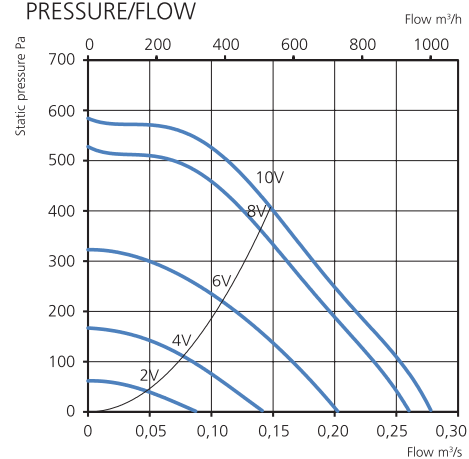

### POWER/FLOW

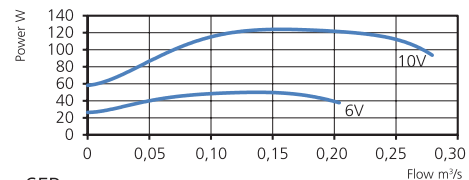

### SFP

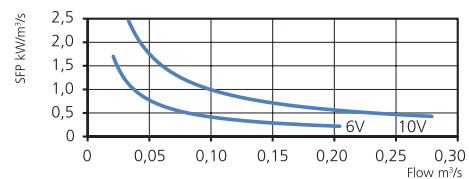

### SOUND DATA

|                         | $L_{wa}$ tot dB (A) | 63 | 125 | 250 | 500 | 1K | 2K | 4K | 8K |
|-------------------------|---------------------|----|-----|-----|-----|----|----|----|----|
| <b>Surrounding 10 V</b> | 54                  | 29 | 31  | 46  | 50  | 47 | 48 | 39 | 31 |
| <b>Outlet 10 V</b>      | 76                  | 58 | 57  | 73  | 68  | 67 | 67 | 63 | 53 |
| <b>Inlet 10 V</b>       | 72                  | 58 | 54  | 69  | 62  | 65 | 62 | 61 | 53 |
| <b>Inlet 8 V</b>        | 69                  | 55 | 52  | 66  | 59  | 62 | 59 | 58 | 50 |
| <b>Inlet 6 V</b>        | 65                  | 47 | 46  | 63  | 54  | 55 | 55 | 49 | 38 |
| <b>Inlet 4 V</b>        | 53                  | 40 | 49  | 45  | 46  | 46 | 42 | 33 | 21 |
| <b>Inlet 2 V</b>        | 39                  | 32 | 26  | 36  | 31  | 27 | 21 | 18 | 10 |

### MORE INFORMATION



Find out the latest updated information about this product by visiting [www.ostberg.com](http://www.ostberg.com) or scanning this QR code.

### DIMENSIONS (mm)

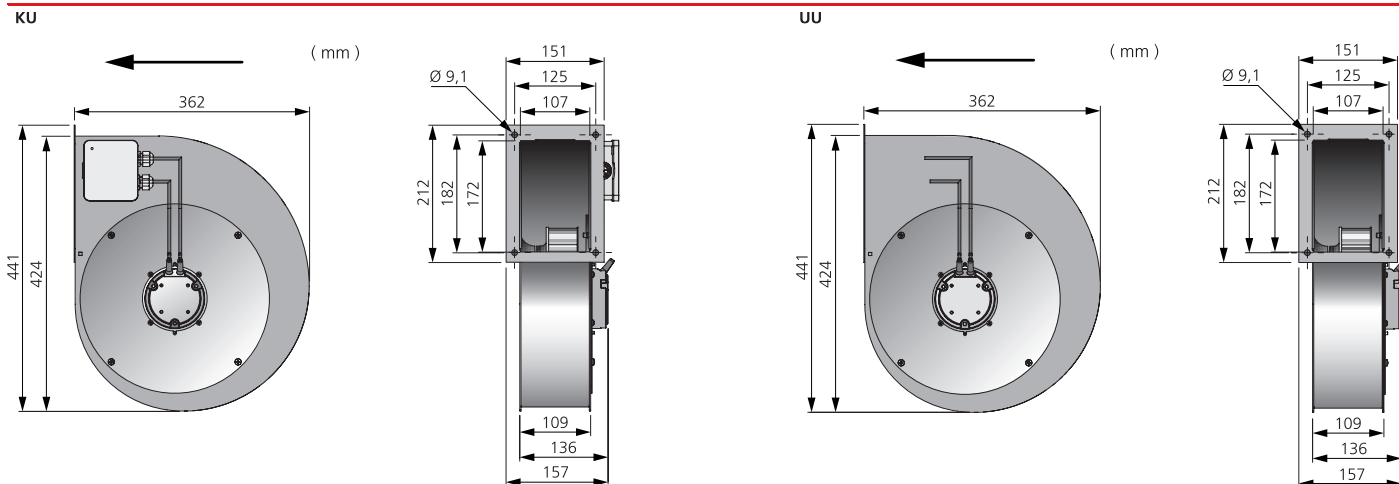



# RBE 225 C EC

KU 7710320, UU 7710316



- Single-phase single inlet radial fan.
- Compact with high capacity and efficiency.
- Low sound levels.
- Impeller with backward curved blades.
- The external rotor motor has maintenance-free sealed ball-bearings.
- The motor is situated in the airstream to get ultimate cooling.
- Integrated motor protection.
- Junction box has enclosure class IP 54.
- Speed controlling can be done with the built-in potentiometer, 0-10 V alt. external control.
- Fan housing is manufactured from galvanized sheet steel.
- Ideal for use in heat exchangers, dehumidifiers and air cleaners.
- Explanations:  
KU = With junction box, without connection pipes.  
UU = Without junction box, without connection pipes.
- All diagrams shown with duct connected fan.



## PRESSURE/FLOW

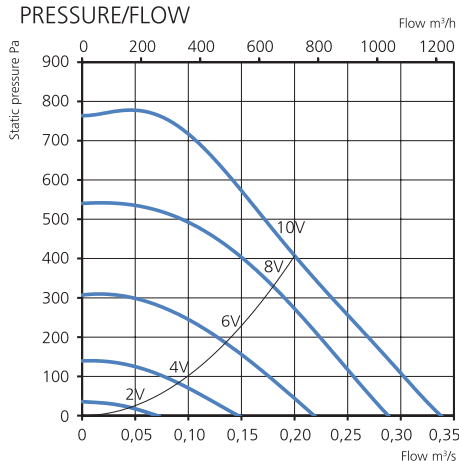

## POWER/FLOW

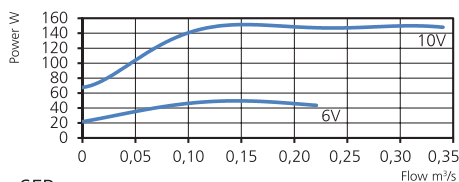

## SFP

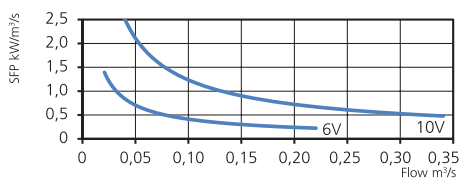

## TECHNICAL DATA

|                                     |             |
|-------------------------------------|-------------|
| <b>Voltage</b>                      | 230 V       |
| <b>Frequency</b>                    | 50/60 Hz    |
| <b>Phase</b>                        | 1 ~         |
| <b>Current</b>                      | 1.21 A      |
| <b>Power</b>                        | 150 W       |
| <b>Speed</b>                        | 2900 r.p.m. |
| <b>Max. temp of transported air</b> | 60 °C       |
| <b>Sound pressure level, 3 m</b>    | 47 dB(A)    |
| <b>Weight</b>                       | 5.7 kg      |
| <b>Enclosure class</b>              | 44 IP       |
| <b>Wiring diagram</b>               | 4040153     |

## ACCESSORIES

- Speed controller MS EC
- Controller IQ-Reg EC

## SOUND DATA

|                         | $L_{WA}$ tot dB (A) | 63 | 125 | 250 | 500 | 1K | 2K | 4K | 8K |
|-------------------------|---------------------|----|-----|-----|-----|----|----|----|----|
| <b>Surrounding 10 V</b> | 54                  | 29 | 31  | 46  | 50  | 47 | 48 | 39 | 31 |
| <b>Outlet 10 V</b>      | 76                  | 58 | 57  | 73  | 68  | 67 | 67 | 63 | 53 |
| <b>Inlet 10 V</b>       | 72                  | 58 | 54  | 69  | 62  | 65 | 62 | 61 | 53 |
| <b>Inlet 8 V</b>        | 69                  | 55 | 52  | 66  | 59  | 62 | 59 | 58 | 50 |
| <b>Inlet 6 V</b>        | 65                  | 47 | 46  | 63  | 54  | 55 | 55 | 49 | 38 |
| <b>Inlet 4 V</b>        | 53                  | 40 | 49  | 45  | 46  | 46 | 42 | 33 | 21 |
| <b>Inlet 2 V</b>        | 39                  | 32 | 26  | 36  | 31  | 27 | 21 | 18 | 10 |

## MORE INFORMATION



Find out the latest updated information about this product by visiting [www.ostberg.com](http://www.ostberg.com) or scanning this QR code.

## DIMENSIONS (mm)

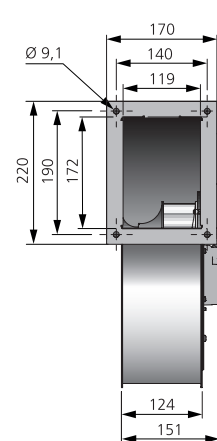
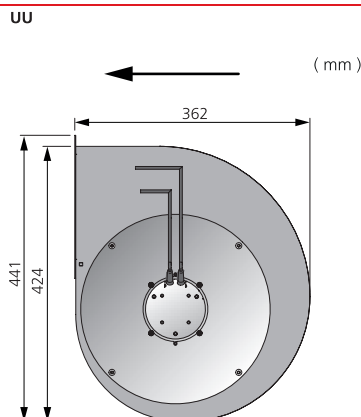
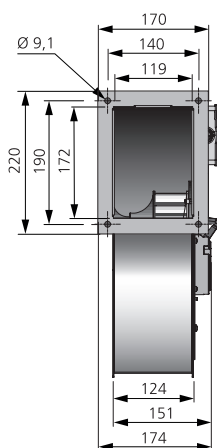
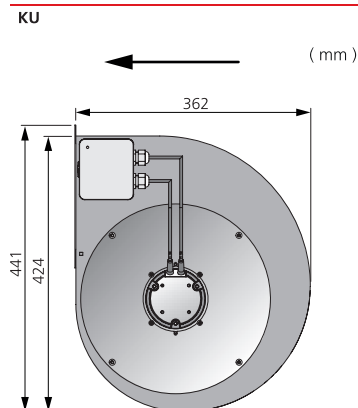

# RADIAL FAN

## DFE 133-4

3097025

- Double inlet radial fan.
- High pressure, large air volumes and low sound levels.
- Impeller with forward curved blades.
- The external rotor motor has maintenance-free sealed ball-bearings.
- The motor is situated in the airstream to get ultimate cooling.
- Integrated motor protection.
- Can be ordered with junction box.
- For speed control a transformer or electronic speed controller can be connected.
- Fan housing is manufactured from galvanized sheet steel.
- Compact design for a minimum amount of space.
- Ideal for use in heat exchangers, dehumidifiers and air cleaners.

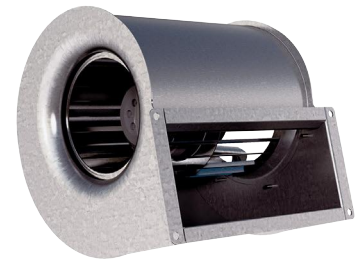

### ACCESSORIES

- Transformer controller VRDE 1.5
- Speed controller VRS 0.5
- Transformer controller VRTE C

### TECHNICAL DATA

|                                     |             |
|-------------------------------------|-------------|
| <b>Voltage</b>                      | 230 V       |
| <b>Frequency</b>                    | 50 Hz       |
| <b>Phase</b>                        | 1 ~         |
| <b>Current</b>                      | 0.28 A      |
| <b>Power</b>                        | 63 W        |
| <b>Speed</b>                        | 1120 r.p.m. |
| <b>Max. temp of transported air</b> | 65 °C       |
| <b>Sound pressure level, 3 m</b>    | 50 dB(A)    |
| <b>Weight</b>                       | 3.2 kg      |
| <b>Enclosure class</b>              | 44 IP       |
| <b>Wiring diagram</b>               | 4040001     |

### PRESSURE/FLOW

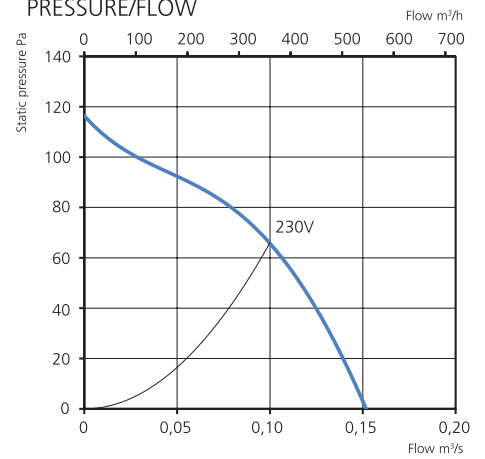

### POWER/FLOW

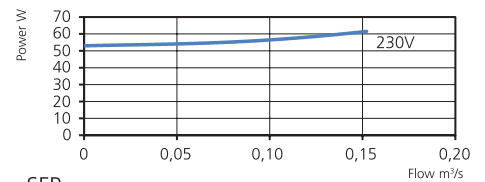

### SFP

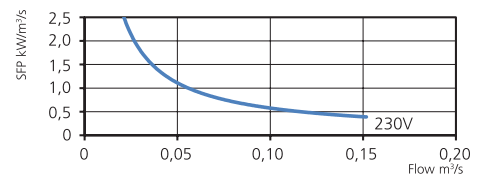

### SOUND DATA

|                          | $L_{WA}$ tot dB (A) | 63 | 125 | 250 | 500 | 1K | 2K | 4K | 8K |
|--------------------------|---------------------|----|-----|-----|-----|----|----|----|----|
| <b>Surrounding 230 V</b> | 57                  | 34 | 37  | 43  | 49  | 54 | 50 | 44 | 40 |
| <b>Outlet 230 V</b>      | 61                  | 48 | 50  | 43  | 48  | 59 | 55 | 48 | 38 |

### MORE INFORMATION



Find out the latest updated information about this product by visiting [www.ostberg.com](http://www.ostberg.com) or scanning this QR code.

### DIMENSIONS (mm)

( mm )

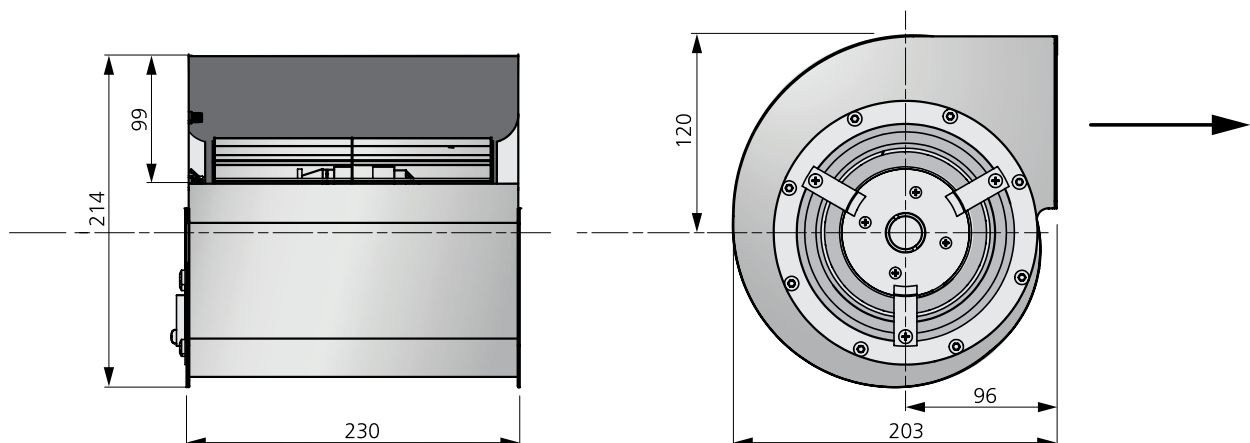

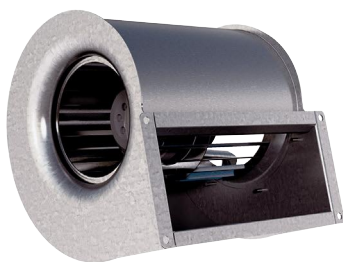

- Double inlet radial fan.
- High pressure, large air volumes and low sound levels.
- Impeller with forward curved blades.
- The external rotor motor has maintenance-free sealed ball-bearings.
- The motor is situated in the airstream to get ultimate cooling.
- Integrated motor protection.
- Can be ordered with junction box.
- For speed control a transformer or electronic speed controller can be connected.
- Fan housing is manufactured from galvanized sheet steel.
- Compact design for a minimum amount of space.
- Ideal for use in heat exchangers, dehumidifiers and air cleaners.

PRESSURE/FLOW

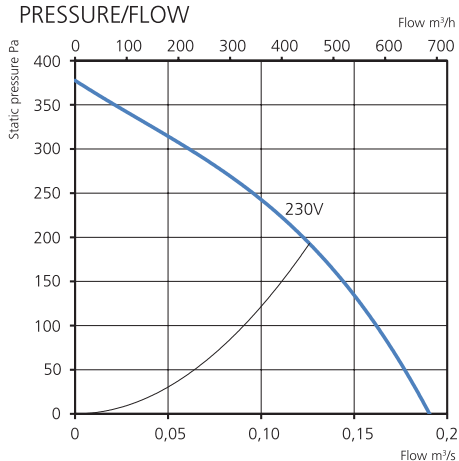

POWER/FLOW

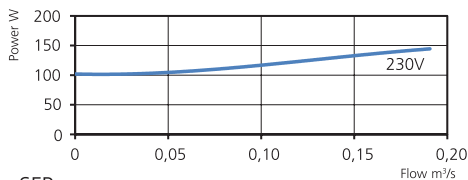

SFP

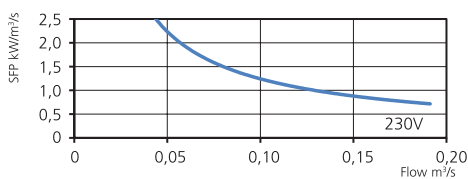

TECHNICAL DATA

|                              |             |
|------------------------------|-------------|
| Voltage                      | 230 V       |
| Frequency                    | 50 Hz       |
| Phase                        | 1 ~         |
| Current                      | 0.64 A      |
| Power                        | 147 W       |
| Speed                        | 1144 r.p.m. |
| Max. temp of transported air | 55 °C       |
| Sound pressure level, 3 m    | 60 dB(A)    |
| Weight                       | 3.7 kg      |
| Enclosure class              | 44 IP       |
| Wiring diagram               | 4040001     |

ACCESSORIES

- Transformer controller VRDE 1.5
- Speed controller VRS 1.0
- Transformer controller VRTE C

SOUND DATA

|                   | L <sub>WA</sub> tot dB (A) |     |     |     |    |    |    |    |    |
|-------------------|----------------------------|-----|-----|-----|----|----|----|----|----|
|                   | 63                         | 125 | 250 | 500 | 1K | 2K | 4K | 8K |    |
| Surrounding 230 V | 67                         | 43  | 49  | 54  | 58 | 62 | 61 | 57 | 50 |
| Outlet 230 V      | 74                         | 56  | 58  | 54  | 58 | 71 | 67 | 64 | 57 |

MORE INFORMATION



Find out the latest updated information about this product by visiting [www.ostberg.com](http://www.ostberg.com) or scanning this QR code.

DIMENSIONS (mm)

( mm )

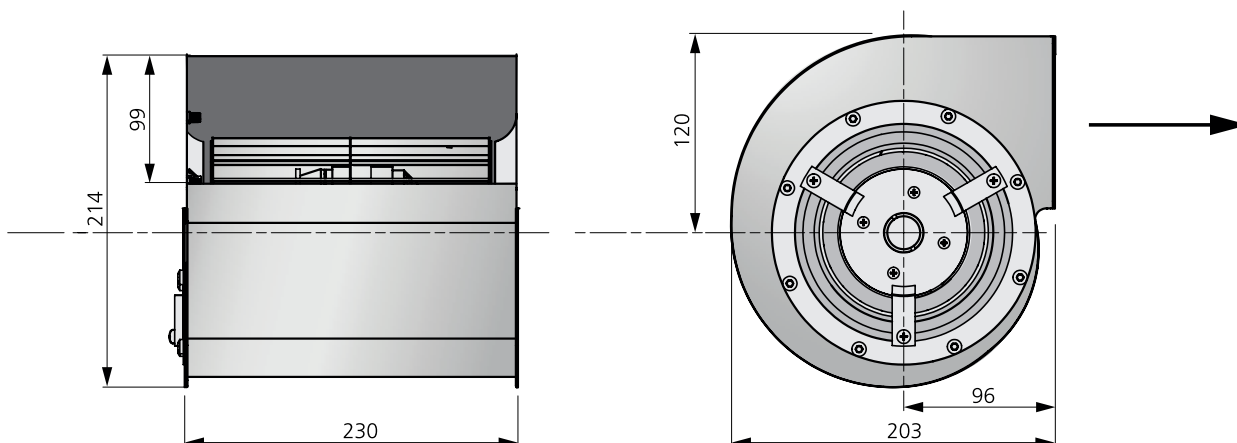

# RADIAL FAN

## DFE 133-21

3091464

- Double inlet radial fan.
- High pressure, large air volumes and low sound levels.
- Impeller with forward curved blades.
- The external rotor motor has maintenance-free sealed ball-bearings.
- The motor is situated in the airstream to get ultimate cooling.
- Integrated motor protection.
- Can be ordered with junction box.
- For speed control a transformer or electronic speed controller can be connected.
- Fan housing is manufactured from galvanized sheet steel.
- Compact design for a minimum amount of space.
- Ideal for use in heat exchangers, dehumidifiers and air cleaners.

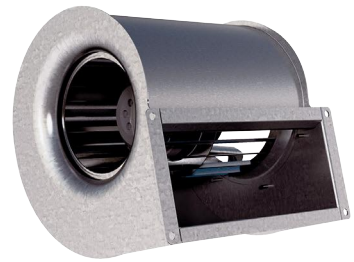

### ACCESSORIES

- Outlet flange
- Transformer controller VRTE 3
- Transformer controller VRDE 1.5
- Speed controller VRS 2.0

### TECHNICAL DATA

|                                     |             |
|-------------------------------------|-------------|
| <b>Voltage</b>                      | 230 V       |
| <b>Frequency</b>                    | 50 Hz       |
| <b>Phase</b>                        | 1 ~         |
| <b>Current</b>                      | 1.15 A      |
| <b>Power</b>                        | 230 W       |
| <b>Speed</b>                        | 2000 r.p.m. |
| <b>Max. temp of transported air</b> | 40 °C       |
| <b>Sound pressure level, 3 m</b>    | 64 dB(A)    |
| <b>Weight</b>                       | 4.2 kg      |
| <b>Enclosure class</b>              | 44 IP       |
| <b>Wiring diagram</b>               | 4040001     |

### PRESSURE/FLOW

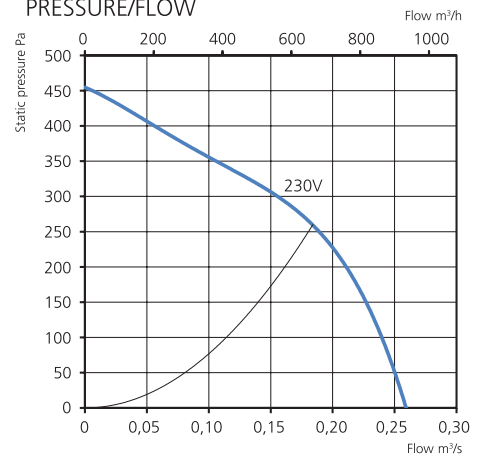

### POWER/FLOW

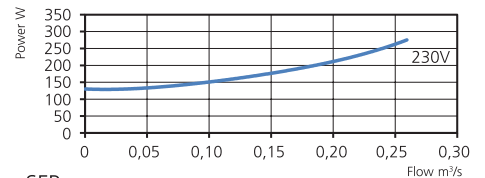

### SFP

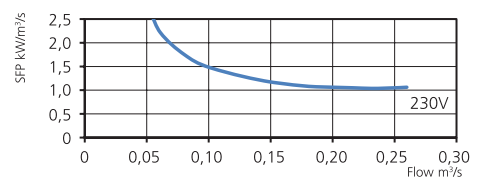

### SOUND DATA

|                   | $L_{wa}$ tot dB (A) | 63 | 125 | 250 | 500 | 1K | 2K | 4K | 8K |
|-------------------|---------------------|----|-----|-----|-----|----|----|----|----|
| Surrounding 230 V | 71                  | 48 | 52  | 61  | 63  | 65 | 66 | 64 | 57 |
| Outlet 230 V      | 78                  | 59 | 62  | 59  | 62  | 73 | 73 | 70 | 65 |

### MORE INFORMATION



Find out the latest updated information about this product by visiting [www.ostberg.com](http://www.ostberg.com) or scanning this QR code.

### DIMENSIONS (mm)

( mm )

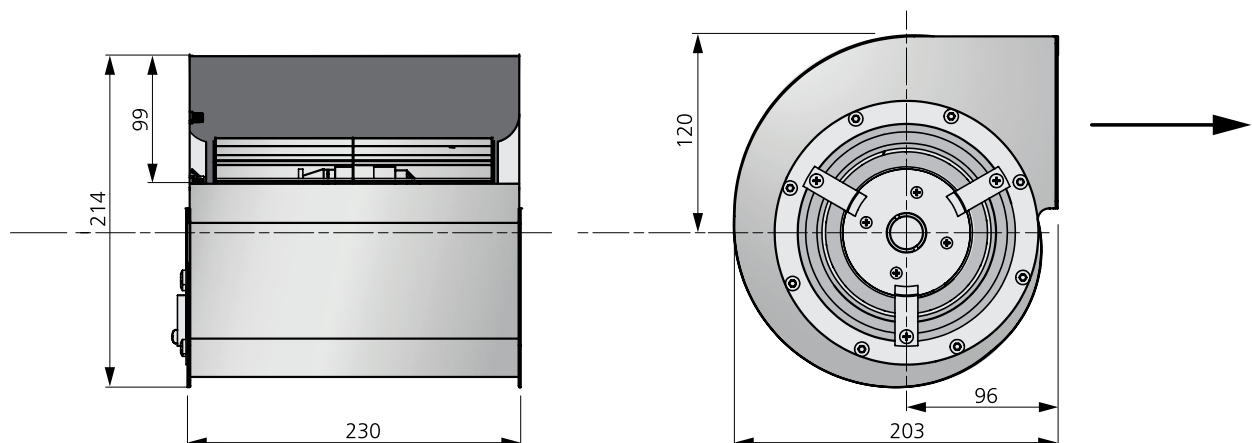

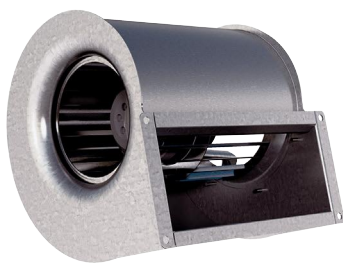

- Double inlet radial fan.
- High pressure, large air volumes and low sound levels.
- Impeller with forward curved blades.
- The external rotor motor has maintenance-free sealed ball-bearings.
- The motor is situated in the airstream to get ultimate cooling.
- Integrated motor protection.
- Can be ordered with junction box.
- For speed control a transformer or electronic speed controller can be connected.
- Fan housing is manufactured from galvanized sheet steel.
- Compact design for a minimum amount of space.
- Ideal for use in heat exchangers, dehumidifiers and air cleaners.

This product does not meet ErP requirements and is not sold within the EU.

PRESSURE/FLOW

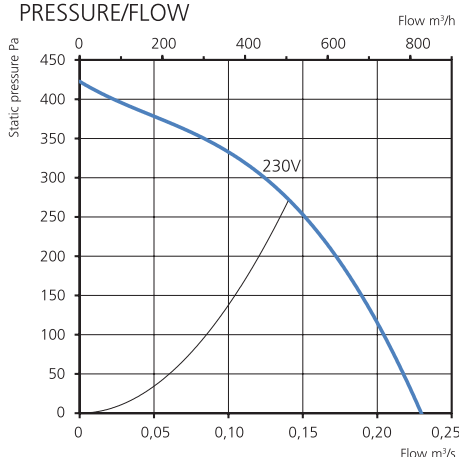

TECHNICAL DATA

|                                     |             |
|-------------------------------------|-------------|
| <b>Voltage</b>                      | 230 V       |
| <b>Frequency</b>                    | 50 Hz       |
| <b>Phase</b>                        | 1 ~         |
| <b>Current</b>                      | 0.85 A      |
| <b>Power</b>                        | 195 W       |
| <b>Speed</b>                        | 1308 r.p.m. |
| <b>Max. temp of transported air</b> | 40 °C       |
| <b>Sound pressure level, 3 m</b>    | 61 dB(A)    |
| <b>Weight</b>                       | 4.2 kg      |
| <b>Enclosure class</b>              | 44 IP       |
| <b>Wiring diagram</b>               | 4040001     |

ACCESSORIES

- Transformer controller VRTE C
- Transformer controller VRDE 1.5
- Speed controller VRS 1.0

POWER/FLOW

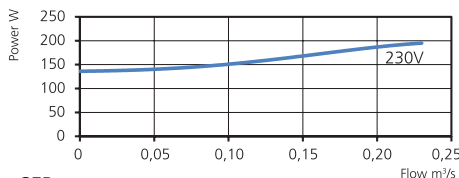

SFP

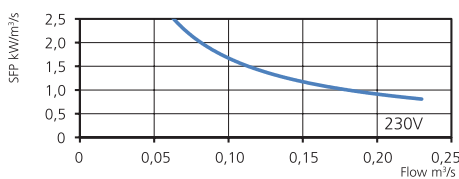

SOUND DATA

|                          | $L_{wa}$ tot dB (A) | 63 | 125 | 250 | 500 | 1K | 2K | 4K | 8K |
|--------------------------|---------------------|----|-----|-----|-----|----|----|----|----|
| <b>Surrounding 230 V</b> | 69                  | 44 | 50  | 57  | 60  | 63 | 64 | 61 | 54 |
| <b>Outlet 230 V</b>      | 76                  | 57 | 61  | 56  | 60  | 73 | 71 | 68 | 62 |

MORE INFORMATION



Find out the latest updated information about this product by visiting [www.ostberg.com](http://www.ostberg.com) or scanning this QR code.

DIMENSIONS (mm)

( mm )

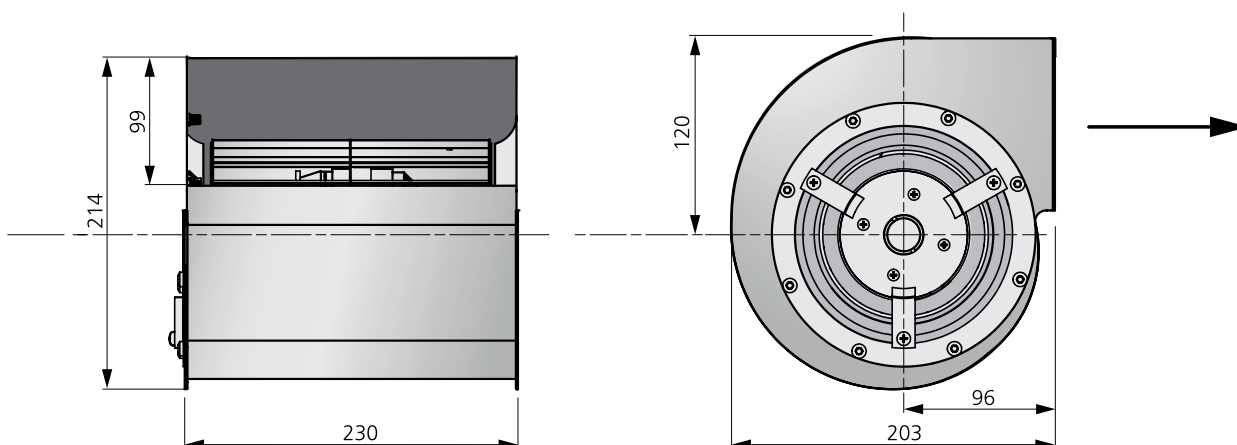

# RADIAL FAN

## DFE 146-S2

7700228

- Double inlet radial fan.
- High pressure, large air volumes and low sound levels.
- Impeller with forward curved blades.
- The external rotor motor has maintenance-free sealed ball-bearings.
- The motor is situated in the airstream to get ultimate cooling.
- Integrated motor protection.
- Can be ordered with junction box.
- For speed control a transformer or electronic speed controller can be connected.
- Fan housing is manufactured from galvanized sheet steel.
- Compact design for a minimum amount of space.
- Ideal for use in heat exchangers, dehumidifiers and air cleaners.

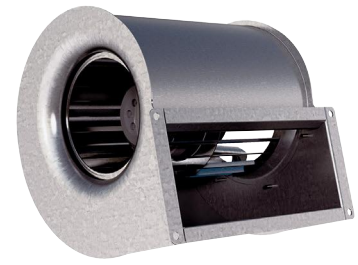

### ACCESSORIES

- Transformer controller VRTE 3
- Transformer controller VRDE 3
- Speed controller VRS 2.0

### TECHNICAL DATA

|                                     |             |
|-------------------------------------|-------------|
| <b>Voltage</b>                      | 230 V       |
| <b>Frequency</b>                    | 50 Hz       |
| <b>Phase</b>                        | 1 ~         |
| <b>Current</b>                      | 1.3 A       |
| <b>Power</b>                        | 290 W       |
| <b>Speed</b>                        | 1950 r.p.m. |
| <b>Max. temp of transported air</b> | 45 °C       |
| <b>Sound pressure level, 3 m</b>    | 66 dB(A)    |
| <b>Weight</b>                       | 5.0 kg      |
| <b>Enclosure class</b>              | 44 IP       |
| <b>Wiring diagram</b>               |             |

### PRESSURE/FLOW

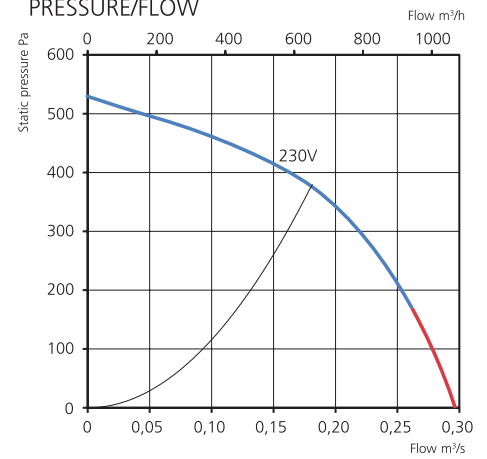

### POWER/FLOW

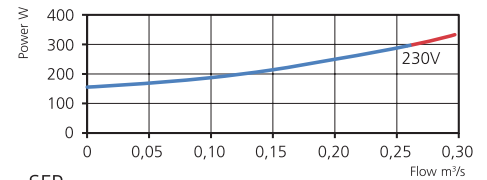

### SFP

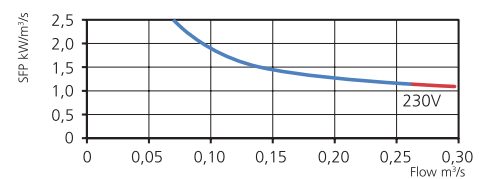

### SOUND DATA

|                          | $L_{WA}$ tot dB (A) | 63 | 125 | 250 | 500 | 1K | 2K | 4K | 8K |
|--------------------------|---------------------|----|-----|-----|-----|----|----|----|----|
| <b>Surrounding 230 V</b> | 73                  | 46 | 52  | 64  | 66  | 66 | 67 | 64 | 57 |
| <b>Outlet 230 V</b>      | 77                  | 58 | 64  | 62  | 65  | 72 | 72 | 70 | 66 |

### MORE INFORMATION



Find out the latest updated information about this product by visiting [www.ostberg.com](http://www.ostberg.com) or scanning this QR code.

### DIMENSIONS (mm)

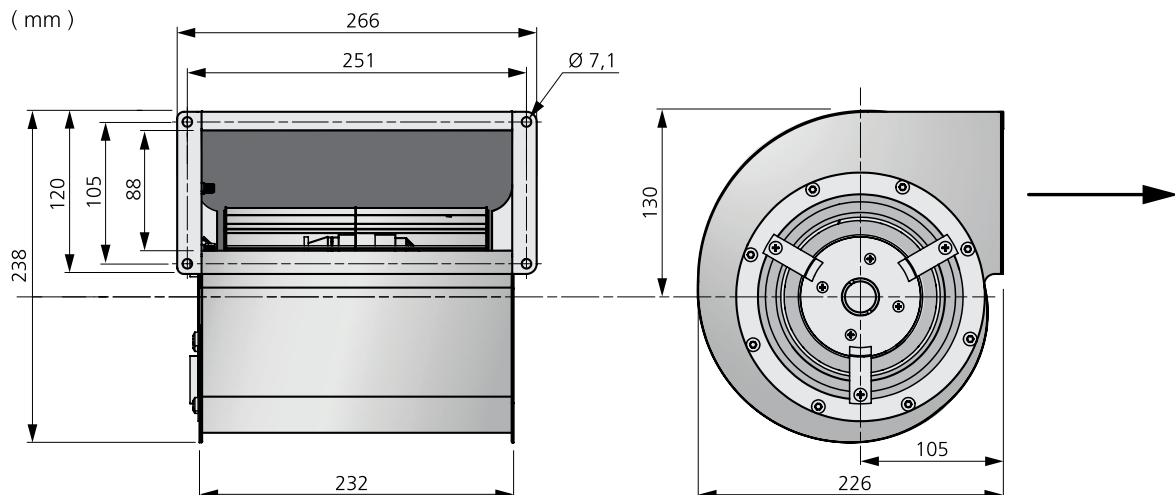

In the following chapter "General Fan Facts" we give some simple explanations, so you can get the most out of reading this catalogue.

Östberg's product catalogue contains a great deal of information. If you choose a product from this catalogue, it is important to understand how this information should be used to ensure that you receive the product that you are expecting.

It is also important to know what standards have been used to compile the measurement data. This is particularly important if you would like to compare fans from different manufacturers, as the results may vary depending on the measuring standards used.

|  |            |
|--|------------|
| <b>FAN WHEELS AND FAN MOTORS .....</b> | <b>436</b> |
| <b>PRESSURE/FLOW DIAGRAMS .....</b>    | <b>437</b> |
| <b>POWER/FLOW DIAGRAMS .....</b>       | <b>438</b> |
| <b>SOUND DATA .....</b>                | <b>439</b> |



# FAN WHEELS AND FAN MOTORS

## FAN WHEELS

Östberg use radial fans in our products. In a radial fan the air stream is angled 90°, the supply air enters in an axial direction and leaves the fan wheel in a radial direction. They have either backward or forward curved impeller blades. In addition to impeller size, fan rotation speed (rpm) is a determining factor in the resulting pressure and flow.

High rotation speeds lead to high flow and pressure, but higher rotation speeds also generate more sound and consume more energy.

### FORWARD CURVED IMPELLER (F WHEEL)

Fans with forward curved impellers provide a compact solution and are most competitive at relatively high pressures, where they also have their highest efficiency.

It is important when choosing a fan with a forward curved impeller to ensure that it is correctly positioned in the area shown in the diagram (Fig. 1, 2 and 3).

At low pressure and high airflow, a forward curved impeller requires a great deal of power from the motor, but the motors are often not designed for this. This is shown with a red line in the pressure/flow diagram and referred to as "prohibited work area". Within this area, the motor overheats very quickly. One drawback of forward curved impellers is that dirt and impurities easily get caught on the concave side of the impeller, which impairs capacity and can cause unbalance. If the impeller gets dirty, it must be cleaned, which can be rather difficult. But a fan with a swing-out function makes this easier.

Forward curved impellers are used in some of our fans, such as RK duct fans, IRE insulated duct fan, RF and DF single and double inlet centrifugal fans and our ATEX certified fans RFTX and RXX.

### BACKWARD CURVED IMPELLER (B WHEEL)

If you choose a fan with backward curved impeller with the same pressure and flow as a fan with forward curved impeller, the fan with backward curved impeller will be larger than the forward curved. The advantage of choosing this type of fan is that the backward curved impellers have higher efficiency, which means that the fan consumes less energy at the same pressure and flow. The backward curved impeller has the highest power

consumption where the efficiency rate is best (Fig. 1, 2 and 3).

Another advantage of these fans is that the impeller does not get dirty as fast as the forward curved, and they are significantly easier to clean when they do. Backward curved impellers are used in our CK, LPKB and RKB duct fans, IRB insulated duct fans, roof fans TKC/S, TKV/H and in our wall fans KV and RS.

## FAN MOTORS

The Östberg range includes products with single-phase or 3-phase AC and EC motors. Our products comply with the Ecodesign directive 209/125/EC.

From the 1 January 2015 a minimum efficiency of fans (motor with fan wheel) with an electric input power between 125 W and 500 kW is required by the second tier in Commission Regulation EU 327/2011. Compliance with these requirements is indicated with the ErP 2015 sign (products with this sign are classified as "fans").

Ecodesign requirements for ventilation units are made in Commission Regulation EU 1253/2014. The second tier of this regulation is valid since 1 January 2018 and sets requirements on minimum fan efficiency for uni-directional ventilation units as well as thermal efficiency and maximum internal specific fan power for bi-directional ventilation units. Compliance with these requirements is indicated with the ErP 2018 sign (products with this sign are classified as "ventilation units").

The increased demand for energy efficiency has caused a shift in the fan motor range, from the conventional AC motor to EC motors with better efficiency and power regulation.

### AC MOTOR

The products in Östbergs range with AC motor have "AC" in the type designation. An induction motor is an electric motor where the rotor speed is asynchronous with the input voltage frequency.

### EC MOTOR

The products in Östbergs range with EC motor have "EC" in the type designation. The EC motor (Electronically Commutated) has an electronic control unit integrated in the motor which increases efficiency by optimally controlling the windings magnetization in the motor in ratio to the rotor.

When comparing an F wheel and a B wheel at corresponding flow and pressure, the diagrams shows that F wheel has a higher pressure and the B wheel gives a better efficiency.

FIG. 1.

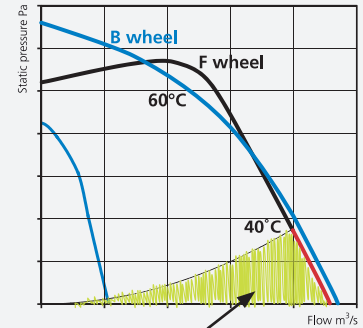

It is important when choosing a fan with a forward curved impeller to ensure that it is correctly positioned in the area shown in the diagram. At low pressure and high airflow, a forward curved impeller requires a great deal of power from the motor. This is shown with a red line in the pressure/flow diagram and referred to as "prohibited work area". Within this area, the motor overheats very quickly.

FIG. 2.

### POWER

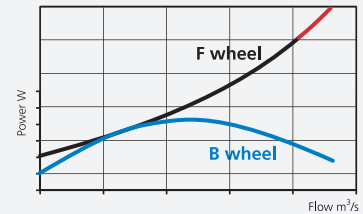

The backward curved impellers has the highest power consumption where the efficiency rate is best.

FIG. 3.

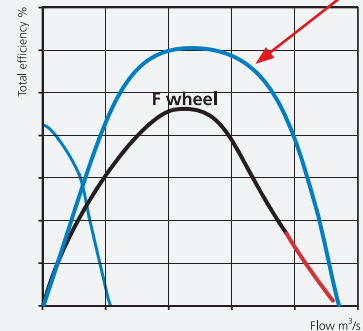

A fan with backward curved impeller have higher efficiency, which means that the fan consumes less energy at the same pressure and flow.



# PRESSURE/FLOW DIAGRAMS

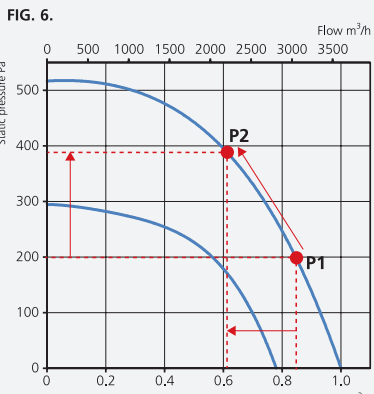
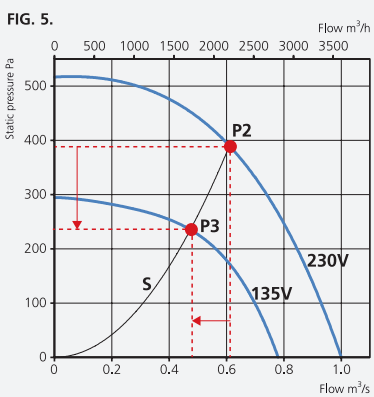
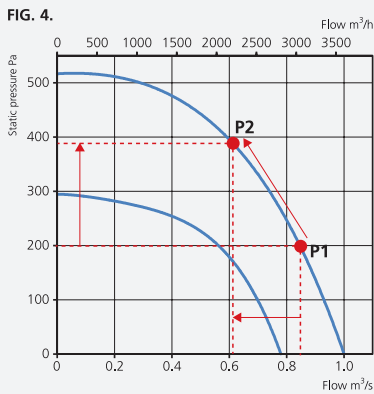

The fan diagrams can also be shown in Total pressure. Total pressure (Pt) = Static (Ps) + Dynamic pressure (Pd). Note what pressure is shown for right data.

When choosing a fan, you must first find out the volume of air the fan is going to transport. Then you have to determine what pressure drop the fan will overcome at this flow. Using this data, you can then choose the size of the fan type you have decided.

### REDUCED FLOW WHEN INCREASED PRESSURE, FIG. 4

The point in the diagram that shows the current flow and pressure is called the fan's working point, which is indicated in this example by **P**.

As the pressure is increasing in the system, the working point will move along the fan curve and a lower flow will be obtained. Working point **P1** is moved to **P2**. This will increase the power consumption.

### REDUCED FLOW WHEN SPEED CONTROLLED, FIG. 5

The System line (S) describes the total ventilation system (ducts, silencers, dampers, diffusers, etc.).

Along this system line, the working point moves from **P2** to **P3** as the rotation speed (voltage) is changed.

Distinct voltage steps with e.g. a transformer, 135V and 230V in this example, produces different fan diagrams, "rotation speed diagrams". This will reduce the power consumption.

### PRESSURE IN DUCT, Fig. 6 AND 7

A fan's pressure is the work the fan performs in addition to supplying a specific flow. A fan's pressure can be presented as total pressure or static pressure.

Static pressure is the pressure that in the duct works at right angles to the duct wall in relation to the pressure outside the duct.

Dynamic pressure works in the duct's longitudinal direction and is dependent on the air velocity in the duct. It is the static current pressure that is dimensioned when choosing a fan for a system. It is the static pressure drop that is calculated for the duct system during the pressure drop calculation.

The static pressure added to the dynamic pressure is the fan's total pressure.

The dynamic pressure, Pd, is calculated as follows:

$$P_d = \rho \cdot v^2 / 2$$

$\rho$  = air density, kg/m<sup>3</sup>

$v$  = air velocity, m/s

Our fan diagrams are shown in **Static pressure**, Pascals (Pa). It is this pressure that must overcome the pressure losses of the ventilation system.

The diagram shows the fan capacity at various points according to the pressure created by ductwork system.

The diagram shows the pressure in Pascals (Pa) on the vertical axis and airflow in cubic metres/seconds (m<sup>3</sup>/s) on the horizontal axis.

FIG. 7.

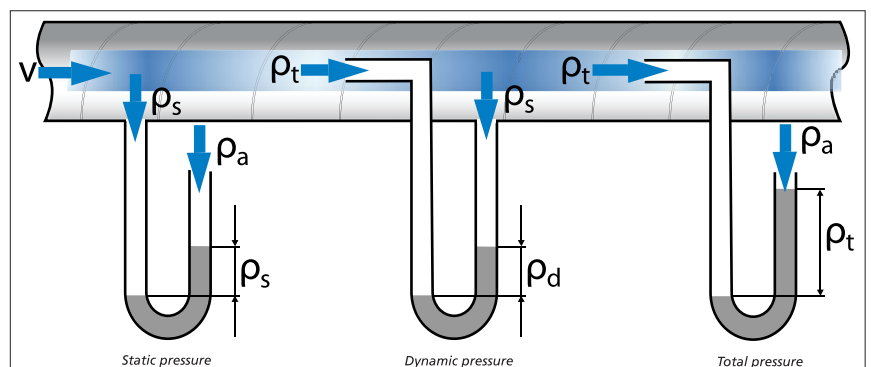

# POWER/FLOW DIAGRAMS

Once you have chosen a fan, the power/flow diagram will show you the amount of power the fan will consume at a certain flow, which will assist you in choosing an energy efficient alternative (Fig. 8).

The electrical equipment, such as rotation speed regulators and fan circuit breakers, must be dimensioned according to technical data/rating, which will specify maximum power consumption (input) and operating current consumption within the permitted working area.

If the current consumption is higher than the rated current, the motor will be overloaded, which considerably shortens the motor's service life. If the winding temperature is too high, the motor's overheating protection will be activated and the motor will stop.

We always specify the motor's input power, but there are fan manufacturers who incorrectly give the motor's output power instead.

You should therefore also compare current consumption figures from different fan manufacturers.

At start-up, current consumption is higher than rated current for a short time. This is called starting current.

Fans with large impellers have longer starting current times. Fans with B-wheels have the highest current consumption in the middle of the curve (Fig. 9) and fans with F-wheels have the highest current consumption at low pressures (Fig. 10).

**TEMPERATURE OF TRANSPORTED AIR**  
In pressure/flow diagrams or in the table of technical data there are facts about highest temperature of transported air

(Fig. 11). All of our fan motors have insulation class F which means that the thermal contact disconnects the power when the winding temperature is maximum 155°C. At this winding temperature the life time of the ball bearings is not optimal. This is why the ambient temperature is shown at a lower winding temperature so the life time of ball bearings becomes optimal.

The winding temperature varies in the diagrams and depending on differences in power/current consumption.

The temperatures in our diagrams are given at the highest winding temperature.

At high current consumption, the most heat is generated in the motors. This heat must be cooled away so that the motor's service life is not affected. Most of our fans have their motors located in the airstream and are cooled by this airstream.

If the air that moves past the motor is too warm, it will not sufficiently cool the motor. For this reason, the highest recommended ambient/air temperatures for the fan are provided. If the fan is used at higher temperatures, its service life will be shortened considerably and the fan's overheating protection will activate.

The temperatures are shown in the curve at the pressure and flow where the ambient temperature is lowest. The motor can handle higher temperatures at other pressures and flows. Motors with F-wheels, for example, are used at higher pressures.

**SPECIFIC FAN POWER, SFP**

The SFP is a measurement for the size of the total power at a specific flow/pressure and is calculated in kW/l/second (Fig. 12).

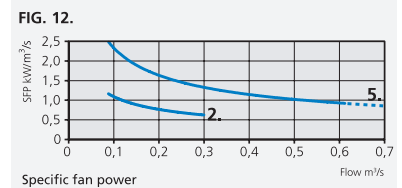
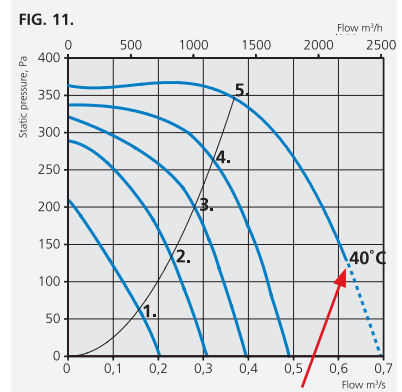
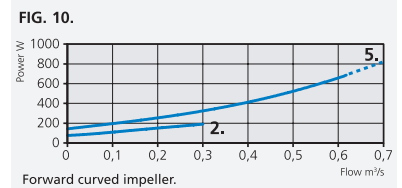
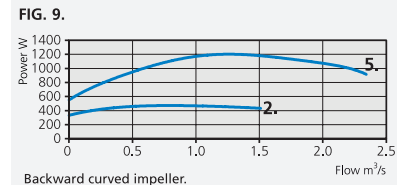
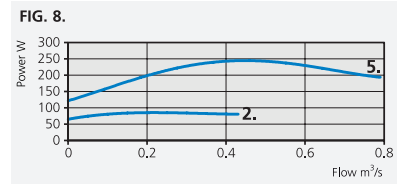

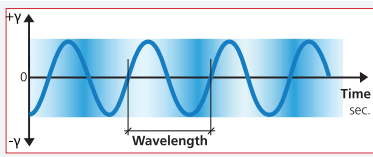

Wavelength for a pure tone. Sound wavelength  $\lambda$  is calculated as  $\lambda = c / f$  where  $f$  is frequency in Hz and  $c$  is the speed of sound in m/s.

| Octave band | Middle frequency Hz | Band limits Hz | Wavelength m |
|-------------|---------------------|----------------|--------------|
| 1           | 63                  | 44-88          | 5.396        |
| 2           | 125                 | 88-177         | 2.720        |
| 3           | 250                 | 177-354        | 1.360        |
| 4           | 500                 | 354-707        | 0.680        |
| 5           | 1000                | 707-1410       | 0.340        |
| 6           | 2000                | 1410-2830      | 0.170        |
| 7           | 4000                | 2830-5660      | 0.085        |
| 8           | 8000                | 5660-11300     | 0.043        |

FIG. 13.

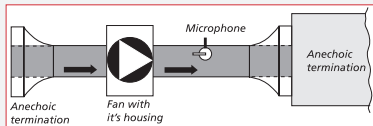

ISO method: Measurements conducted inside a duct with specified design and non-reflecting connection. Measurements and calculations conducted in 1/1 octave band.

FIG. 14.

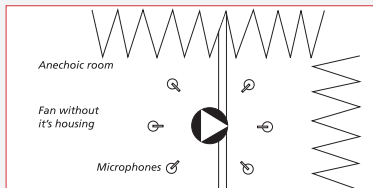

AMCA method: Measurement conducted on free-standing fan in fully soundproof room. Results in lower sound levels.

FIG. 15.

|                |        |        |        |        |
|----------------|--------|--------|--------|--------|
| Octave band Hz | 63     | 125    | 250    | 500    |
| Inaccuracy dB  | +/-5,0 | +/-3,4 | +/-2,6 | +/-2,6 |
| Octave band Hz | 1000   | 2000   | 4000   | 8000   |
| Inaccuracy dB  | +/-2,6 | +/-2,9 | +/-3,6 | +/-5,0 |

The sound level that we experience is the intensity of the pressure fluctuations that the sound consists of. Pressure fluctuations can be measured and given in Pascals, Pa, and are called sound pressure.

The lowest sound that the human ear can register is a pressure difference of 0.00002 Pa (hearing threshold). The highest pressure is 20 Pa (pain threshold). To make it easier to report sound levels, a logarithmic scale is used instead of Pascals. This scale is called Bell, or more commonly, decibel, and is abbreviated dB. The decibel scale ranges from 0 dB (hearing threshold) to 120 dB (pain threshold). One advantage of this is that the human ear registers sound levels logarithmically, which means that a difference of 1 dB is perceived equally across the entire scale. An increase of 6 dB equals a doubling of sound pressure, but an increase of 10 dB is required for us to perceive this increase as having doubled.

The human ear can discern a 3 dB difference in sound pressure.

SOUND DATA

In our catalogues, we give the sound power level  $L_w(A)$  and sound pressure level  $L_p(A)$  for sound in ducts and sound that is transmitted to the surroundings (through the fan casing). Values are measured in accordance with ISO 3741 for sound transmitted to the surroundings from the fans, or ISO 5136 for measurements of sound power level to the ducts. Note that measurements conducted according to another standard may differ from the measurement data in these ISO standards.

We conduct sound measurements according to the ISO method, in which the fan is measured in its casing to provide the most realistic values. (Fig.13.) Measurements conducted on free-standing fans without casing result in lower sound levels. In Application of Manufacturers' Sound Data, industry organization ASHRAE in the US states that: "Measurements conducted on free-standing fans have 5-10 dB lower sound

levels in octave bands from 250 Hz, and lower sound levels than fans in fan casing." (Fig.14.)

MEASUREMENT INACCURACY

In conjunction with the preparation of its measuring method for sound power levels in ducts, ISO analyzed inaccuracy in various octave bands (90% reliability). (Fig.15.)

SOUND POWER LEVEL

Sound power level,  $L_w(A)$ , is used to calculate the sound generated from the entire ventilation system. The system consists of components such as dampers, ducts, diffusers, grilles, etc., all of which contribute to the total sound power for the entire system.

The sound power level is a calculated value that specifies the source intensity or the acoustic power emitted; it does not indicate how strongly the sound is perceived. Sound power level is reported in octave bands **63-8000 Hz** and as a logarithmic composite sum  $L_w(A)_{tot}$ .

SOUND PRESSURE LEVEL

Sound pressure level,  $L_p$ , indicates how the sound is perceived. It is calculated in relation to a reference sound pressure,  $P_0$ , which is the hearing threshold, as follows:

$$L_p = 10 \log (P/P_0)^2 \quad L_p = 20 \log P/P_0$$

Where  $P_0 = 2 \times 10^{-5}$  (Pa)

Sound pressure varies according to distance and direction from the source of the sound. The acoustic properties of the surroundings also affect sound pressure.

The sound pressure level is presented for a normally soundproofed room with an equivalent absorption area of 20 m<sup>2</sup>.

A difference of 7 dB corresponds to a distance of roughly 3 m to the sound source with semi-spherical propagation of sound. In an attempt to simulate how the human ear perceives the sound at the different frequencies, it is weighted (corrected in the octave band) to weighting curve **A** which is presented as  $L_p(A)$  and by the unit **dB(A)**. (Fig.16.)

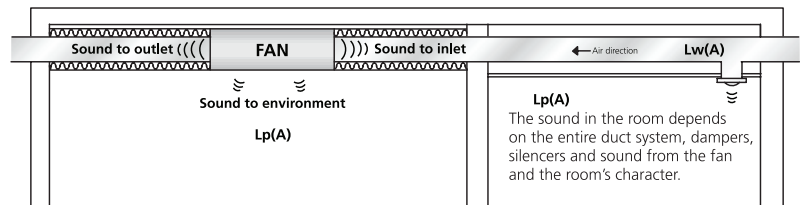

FIG. 16.

| Frequency                                   | 63  | 125 | 250 | 500 | 1000 | 2000 | 4000 | 8000 |
|---|-----|-----|-----|-----|------|------|------|------|
| Measured sound pressure level $L_p$ dB      | 50  | 46  | 30  | 25  | 20   | 18   | 15   | 15   |
| A filter                                    | -26 | -16 | -9  | -3  | 0    | +1   | +1   | -1   |
| A-weighted sound pressure level $L_p(A)$ dB | 24  | 30  | 21  | 22  | 20   | 19   | 16   | 14   |

Tabell A-filter

The dB scale is logarithmic and following the logarithmic addition of the above sound pressure levels, the total is 32,5 dB(A).  $dB_{tot} = 10 * \log [10^{(dB 1/10)} + 10^{(dB 2/10)}]$

$$L_p = 10 \times \lg (10^{L_{p1}/10} + 10^{L_{p2}/10} + \dots + 10^{L_{pn}/10})$$

FAN FACTS



Following chapter contains all wiring diagrams we use in our products. Each wiring diagram is also printed on the product label.

# WIRING DIAGRAMS

**4040001**  
Single phase 230 V.

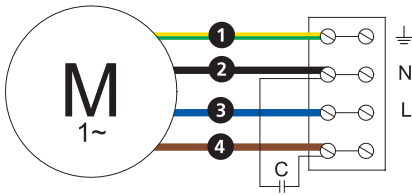

**4040002**  
Single phase 230 V.

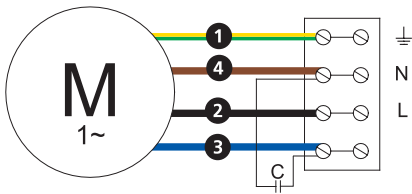

**4040003**  
3-phase Δ230 V

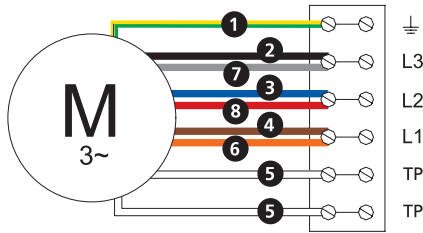

**4040004**  
3-phase Y400 V.

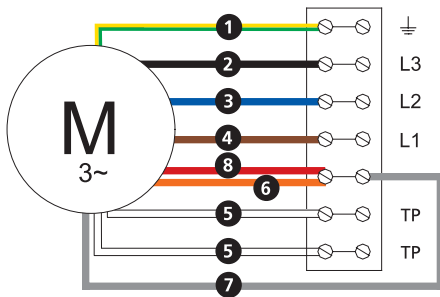

**4040005**  
Single phase 230 V.

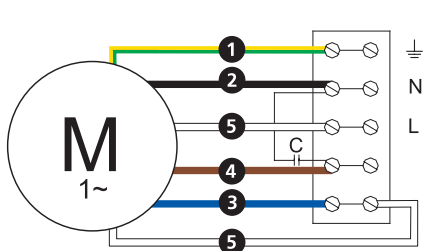

**4040015**  
Single phase 230 V.

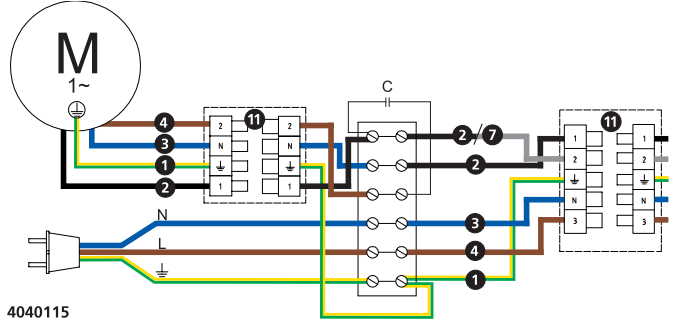

**4040115**  
3-phase 400 V.

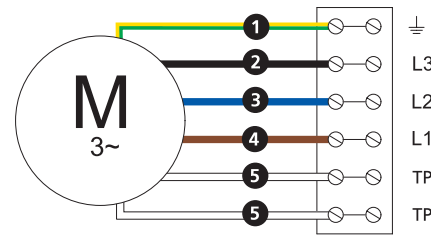

**4040116**  
3-phase 400 V.

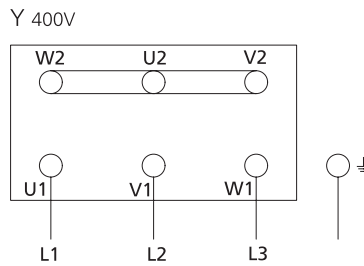

**4040143**  
Single phase 230 V.

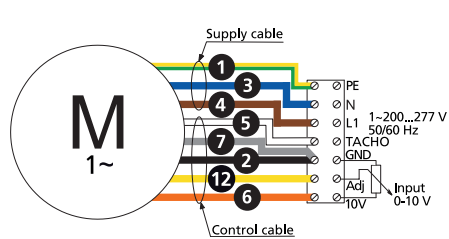

**4040145**  
Single phase 230 V.

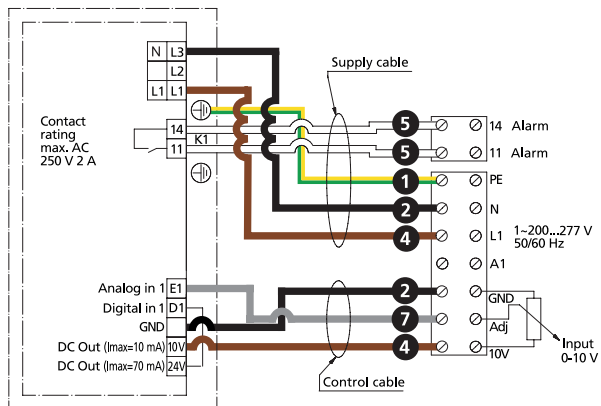

**4040147**  
3-phase 400 V.

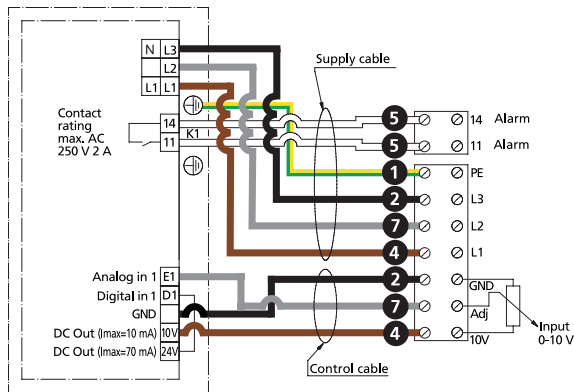

**4040175**  
Single Phase 230 V.

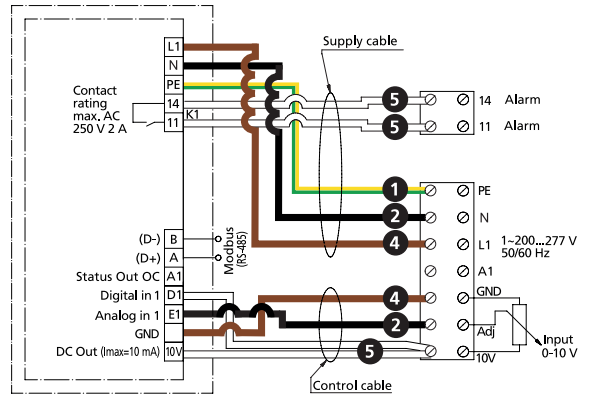

**4040153**  
Single phase 230 V.

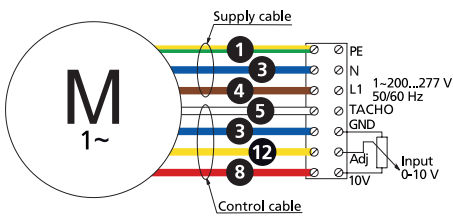

**4040180**  
Single phase 230 V.

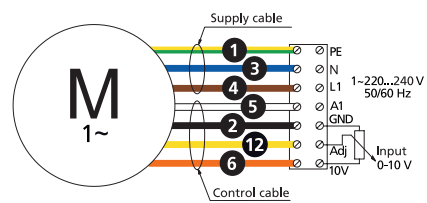

- (M) = Fan Motor
- (M1) = Fan Motor
- (M2) = Fan Motor
- ① = Yellow/Green
- ② = Black
- ③ = Blue
- ④ = Brown
- ⑤ = White
- ⑥ = Orange
- ⑦ = Grey
- ⑧ = Red
- ⑨ = Green
- ⑩ = Violet
- ⑪ = Quick switch
- ⑫ = Yellow

**4040191**  
Single phase 230 V.

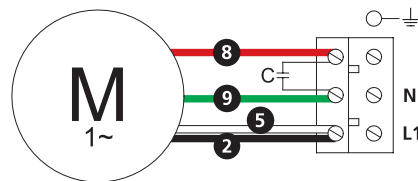

**4040195**  
Single phase 230 V.

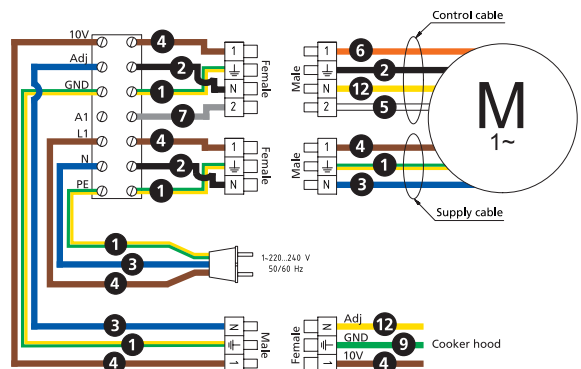









**ÖSTBERG** 

**H ÖSTBERG AB**

Box 54, SE-774 22 Avesta, Sweden

Phone: +46 226 860 00

E-mail: [info@ostberg.com](mailto:info@ostberg.com)

[www.ostberg.com](http://www.ostberg.com)

# healthy indoor climate

ÖSTBERG supplies the world with energy efficient, top-notch ventilation products for a fresh and healthy indoor climate wherever people live, work or play

Join Us On Social Media  
[www.ostberg.com](http://www.ostberg.com)

