



DUCT SYSTEMS

PRODUCT PROGRAMME



D E D I C A T E D T O C L E A N A I R

Sales, delivery and payment terms

1. Applicability:

These sales, delivery and payment terms (hereinafter "the Terms") apply to all offers, orders and deliveries supplied by JKF Industri A/S, CVR no. 17085204 (hereinafter "JKF Industri") to any customer (hereinafter "the Buyer") (hereinafter collectively referred to as "the Parties"), unless expressly agreed otherwise.

JKF Industri cannot be bound by terms applied by the Buyer, including purchasing terms, even if JKF Industri has not objected to such terms.

2. Offers

All offers are made subject to the goods being unsold. If JKF Industri makes an offer that does not stipulate a specific time for acceptance, the offer will expire if not accepted by the Buyer within 30 days of the date of the offer.

3. Prices

All prices are stated in DKK excluding VAT, customs duties, taxes, transport costs and all other costs which are the responsibility of the Buyer arising from the contractual EXW clause (see below). Prices are stated in EUR exclusive of the aforementioned costs for Buyers located in countries, which are members of the European Economic and Monetary Union (the Euro).

4. Sales and delivery terms

Payment terms are current month + 20 days net calculated from the date of invoice unless otherwise agreed in writing.

If payment is made after the due date and the delay is no fault of JKF Industri, JKF Industri is entitled to charge interest on the sum outstanding as from the due date, at a rate equivalent to 1.5 % per month or part thereof.

The Buyer is not entitled to offset any counterclaims against JKF Industri unless expressly agreed in writing by JKF Industri, and does not have the right to withhold any of the purchase sums by reason of counterclaims of any kind.

5. Retention of title

For Buyers in the United Kingdom:

The goods shall remain the property (i.e. title) of JKF Industri until: (i) the full price for them is paid; and (ii) all sums for any other goods or services then properly due and payable from the Buyer are paid to JKF Industri. JKF Industri may at any time attribute any money received by it from the Buyer in any order as JKF Industri may decide. Until such payment, the Buyer shall hold the goods on a fiduciary basis as the bailee or depository of JKF Industri, and shall not dispose of them. However, subject to JKF Industri's prior written consent, the Buyer may on the Buyer's own account sell the goods to any customers but shall not do so after any step is taken or made for any composition or arrangement with creditors generally, liquidation, winding-up, dissolution, administration, receivership or bankruptcy of the Buyer. If any such step occurs, or JKF Industri reasonably expects that such a step is soon to occur, or any payment due to JKF Industri from the Buyer becomes overdue, JKF Industri may by written notice terminate the Buyer's right (if any) to sell the goods and JKF Industri may then recover such goods and for that purpose enter any premises, subject to the Buyer's continued liability to pay the price for the goods. If the item has been sold with a view to later being built into or joined to other objects, the item sold is not covered by the right of retention once such installation or joining has taken place.

JKF Industri reserves the right within the limitations of mandatory laws to retention of title to the item sold until payment for the entire purchase sum, plus any costs incurred, has been made to JKF Industri. If the item has been sold with a view to later being built into or joined to other objects, the item sold is not covered by the right of retention once such installation or joining has taken place.

For Buyers outside the United Kingdom:

JKF Industri reserves the right within the limitations of mandatory laws to retention of title to the item sold until payment for the entire purchase sum, plus any costs incurred, has been made to JKF Industri. If the item has been sold with a view to later being built into or joined to other objects, the item sold is not covered by the right of retention once such installation or joining has taken place.

6. Delivery

Unless otherwise agreed in writing between the Parties, the delivery dates stated are EXW JKF Industri's address, with a proviso for possible schedule overruns (see below). The use of EXW means that the goods are deemed to have been delivered and the order fulfilled from the moment they are made available for collection by the Buyer from JKF Industri's address.

Unless otherwise agreed in writing between the Parties, JKF Industri is authorised to order transport on the usual terms on behalf of the Buyer. The Buyer, will continue to bear the risk for arranging transport, and if it cannot be arranged, the goods will be deemed to be delivered from the time at which JKF Industri states the purchaser can collect them. Regardless of which of the Parties has ordered it, shipping will always be at the risk and expense of the Buyer. Transport insurance (if any) will be the responsibility of the Buyer. The delivery clause (EXW) agreed between the Parties is to be interpreted in accordance with the INCOTERMS current at the time of signing the agreement (currently INCOTERMS 2010).

The delivery date is set by JKF Industri according to the best judgement, and if this cannot be kept to, the Buyer will be informed accordingly, with when, as far as possible, delivery can be expected to take place. Any delay does not give the Buyer the right to cancel the sale and/or claim any form of financial compensation from JKF Industri.

7. Packaging

Packaging may only be returned by prior written agreement. Return of packaging is at the Buyer's own expense and risk. The Buyer's packaging will be credited after reception and approval by JKF Industri.

8. Product information and confidentiality

All illustrations, technical drawings and brochures issued by JKF Industri before or after the contract have been entered into remain the property of JKF Industri and must be returned to JKF Industri on request. Such materials must be treated with strict confidentiality and cannot be used, copied or passed on without written agreement, or abused in any other manner.

The Buyer undertakes to generally observe confidentiality concerning all aspects of JKF Industri known to the Buyer as a result of the information the Parties have exchanged in the course of their dealings.

Breach of this provision by the Buyer shall incur a fine payable to JKF Industri of DKK 75,000. The fine shall be payable for each breach of the provision, and if the breach consists of continuation of a previous breach, the fine shall be payable for each 14 day period of continuation or part thereof. Payment of a fine shall not relieve the Buyer of the above obligations, nor prevent or constrain JKF Industri from claiming compensation for any loss JKF Industri may have incurred arising from the breach, in that payment of the fine by the Buyer shall not be included in calculation of JKF Industri's loss. In addition to the above, JKF Industri is entitled to take out an injunction.

9. Liability for defects and deficiencies and warranty claims

Upon receipt of the goods sold at the Buyer's address, the Buyer shall immediately perform a thorough examination of the goods, including quantity and specifications.

Should the Buyer wish to claim for any defects or deficiencies, including with regard to the quantity or specifications delivered, which the Buyer has or should have discovered in the course of thorough examination of the goods, a written claim shall be submitted to JKF Industri without undue delay and within 14 days of receipt of the goods at the Buyer's address. JKF Industri is entitled to reject any claims received after the expiry of the period stated above.

JKF Industri warrants performing redelivery/remedy of goods which are defective or deficient due to material or manufacturing error for goods which the Buyer has not nor should have discovered by thorough examination for a period of 12 consecutive months after delivery. However, the Buyer shall submit a claim to JKF Industri immediately if discovering such defects or deficiencies.

Defective or deficient goods will either be remedied or replaced within a reasonable period of time at JKF Industri's discretion. Modification/interference with the goods without JKF Industri's written consent releases JKF Industri from any obligation.

Remedy/redelivery by JKF Industri of elements of a delivery shall be on the same terms and conditions as for the original delivery, including those stated in item 6. JKF Industri's obligation to remedy or redeliver does not, however, apply to any part of an order more than 1 year after delivery to the Buyer.

Once liability for the order has been transferred to the Buyer, JKF Industri bears no responsibility for any defects over and above the obligations specified in this provision.

10. Force majeure

The following circumstances are intended as examples of events resulting in exemption from liability should they prevent fulfilment of the contract:

Industrial disputes, strikes, lockout or any other circumstances beyond the control of the parties, such as fire, war, mobilisation, unforeseen military call-up, acts of sabotage, requisitioning, confiscation, currency restrictions, import ban, export ban, riots, unrest, fuel shortage, general scarcity of goods, restrictions in power supplies and defects in deliveries from sub-suppliers or delays with such deliveries as a result of any of the aforementioned circumstances.

It should be specifically noted that the above is not an exhaustive list of examples, and there may be other examples that come under limitation of liability. If delivery is temporarily delayed by one or more of the aforementioned circumstances, the delivery date will be correspondingly postponed. If delivery is prevented for more than 12 weeks, JKF Industri is entitled to cancel the relevant contract without liability.

11. Returns

Items sold can only be returned by prior written agreement, and upon obtaining a returned goods order number. Return will be at the Buyer's expense and risk and should include JKF Industri's invoice number and the date of the original delivery.

Returned goods will be credited once they have been inspected and approved, normally to the value of 85% of invoice price (unless otherwise agreed in writing), less any costs incurred by JKF Industri for inspection, preparation or repair. Custom made goods will not be credited. If JKF Industri is charged for shipping costs etc., JKF Industri is also entitled to demand these be refunded by the Buyer and to offset these against any claims by the Buyer against JKF Industri.

12. Product liability

JKF Industri is not liable for damage to property or effects that occur while the item is in the possession of the Buyer. Neither is JKF Industri liable for damage to products manufactured by the Buyer or to products of which these form a part. JKF Industri is not liable for any operating loss, lost earnings or other indirect loss.

To the extent that product liability may be imposed on JKF Industri with regard to third parties, the Buyer is obliged to compensate JKF Industri to the same extent that JKF Industri's liability is limited as per the above. These limitations to JKF Industri's liability do not apply if JKF Industri is guilty of gross negligence. If a third party puts forward a claim against one of the Parties for compensation with reference to this point, that party must immediately inform the other party. The Buyer can be sued at the same court that handles any claims for compensation against JKF Industri, in consequence of damage alleged to have been caused by one of JKF Industri's deliveries. JKF Industri's product liability can never exceed the cover JKF Industri has for product liability insurance.

13. Compensation

Notwithstanding the above, JKF Industri cannot be held liable for any indirect loss such as operating loss, consequential loss, loss of profit etc., which a defect or deficiency could cause the Buyer or a third party, including indirect loss etc., arising as a result of delayed delivery or defects/deficiencies in the goods sold.

Any compensation claim against JKF Industri cannot exceed the invoice value for the goods sold.

14. Invalidity

Should one or more of the provisions in these terms be deemed invalid, illegal or non-applicable, the validity, legality or applicability of all other provisions shall not be affected or lessened as a result thereof.

15. Jurisdiction and court of venue

All disputes between the parties shall be settled under Danish Law including the Danish Sale of Goods Act, but with the exception of Danish jurisdiction rules. The International Sale of Goods Act (CISG) shall neither be wholly nor partially applied.

Any dispute regulated by the terms shall be resolved by arbitration at the Danish Institute of Arbitration, according to the institute's rules, which apply when an arbitration case is brought with the amendments stated below.

However, the Parties agree that the arbitral tribunal shall consist of 3 members, of whom each party will appoint one member, and the Danish Institute of Arbitration will appoint the tribunal chairman. If a party fails to appoint a member within 14 days of being requested to do so by the Danish Institute of Arbitration, the institute will appoint a member on behalf of that party.

The tribunal shall sit in Hadsund.

The original version of this document is in Danish. In the event of discrepancies between the Danish and English versions, the Danish version will take preference.

Table of contents

Section 00. General

Sales, delivery and payment terms	Page 02
Table of contents	Page 03
JKF duct systems	Page 04 - 05
Assembly methods, galvanised duct systems	Page 06
Assembly methods, 2 and 3 mm duct systems	Page 07

Section 01. Galvanised duct systems

Laser welded and longitudinally lock formed ducts, galv.....	Page 08
Telescopic ducts, galvanised	Page 09
Ducts with access door, galvanised	Page 10
Ducts with cleaning spigot, galvanised.....	Page 11
Pressed bends, galvanised.....	Page 12
Segment bends, galvanised.....	Page 13
30° straight branch pieces, galvanised	Page 14
45° straight branch pieces, galvanised	Page 15
30° conical branch pieces, galvanised	Page 16
45° conical branch pieces, galvanised	Page 17
30° branch plates, galvanised	Page 18
45° branch plates, galvanised	Page 19
30° and 45° trouser pieces, galvanised	Page 20
90° T-pieces, galvanised	Page 21
Tapers, galvanised.....	Page 22
Transition pieces, galvanised	Page 23

Section 02. 2 and 3 mm duct systems

Ducts, 2 and 3 mm.....	Pages 24-25
Telescopic ducts, 2 mm.....	Page 26
Ducts with direct flange, 2 and 3 mm.....	Page 27
Welding ends, 2 and 3 mm	Page 28
Pressed bends, 2 and 3 mm.....	Page 29
Segment bends, 2 and 3 mm	Page 30
30° straight branch pieces, 2 and 3 mm	Page 31
45° straight branch pieces, 2 and 3 mm	Page 32
30° conical branch pieces, 2 and 3 mm	Page 33
45° conical branch pieces, 2 and 3 mm	Page 34
30° trouser pieces, 2 and 3 mm.....	Page 35
90° T-pieces, 2 and 3 mm.....	Page 36
Tapers, 2 and 3 mm.....	Pages 37- 38
Transition pieces, 2 and 3 mm	Page 39

Section 03. JK-6" duct systems

JK-6" duct systems	Pages 40 - 41
--------------------------	---------------

Section 04. Sliding dampers, throttle valves, diverters

Automation for sliding dampers, throttle valves and diverters.....	Page 42
Tight sliding dampers, ø50 - ø500 mm, galv., manual, pneumatic	Page 43

Section 04. Sliding dampers, throttle valves, diverters

Sliding dampers, ø80 - ø500 mm, galv., manual	Page 44
Throttle valves, ø80 - ø160 mm, galv., manual, pneumatic, electric.....	Page 45
Throttle valves, ø180 - ø500 mm, galv., manual, pneumatic, electric.....	Page 46
60° branch diverters, pressed, manual, pneumatic, electric.....	Page 47
45° branch diverters, pressed, manual	Page 48
45° branch diverters, welded, manual, pneumatic, electric	Page 49
60° trouser diverters, pressed, manual, pneumatic, electric.....	Page 50
60° trouser diverters, welded, manual, pneumatic, electric	Page 51
False air valves, galvanised	Page 52

Section 05. Pull rings

Pull rings, galvanised.....	Page 54
Rubber gasket rings	Page 55

Section 06. Rapid lock pull rings

Rapid lock pull rings, galvanised	Page 56
---	---------

Section 07. Flanges

Flanges	Page 57
Rubber flanges	Page 58

Section 08. Caps

Jet caps, galvanised	Pages 59 - 60
Rain caps, galvanised	Page 61

Section 09. Accessories

Clip bands, galvanised	Page 62
Clip bands, primed, heavy design	Page 63
Cutting screens, galvanised.....	Page 64
Sweep ups, galvanised.....	Page 65
Sputniks, galvanised	Page 66
Purflex hoses	Page 67
Sanding tables, galvanised	Page 68

Section 10. Appendix

Appendix 1	Page 69
------------------	---------

JKF Duct Systems

JKF's programme includes galvanised duct systems and welded duct systems in 2 and 3 mm material thickness, and thus represent the basic element in extraction and transport of particles and air.

JKF's duct systems have a circular cross section, with a wide range of ducts, bends, trouser-, branch-, end-, transition and taper pieces, throttle valves, diverters, jet- and rain caps etc. to ensure individual adaptation and a high degree of flexibility.

This catalogue covers JKF's standard components for the following dimensions: $\varnothing 80 - \varnothing 1000$ mm.

Special customised components are available to order.

Galvanised duct system

The galvanised duct system includes all components necessary for a complete and flexible extraction solution and can be used for particle transport, welding extraction etc.

- laser welded ducts
- longitudinally lock formed ducts
- pressed bends
- tight sliding dampers
- branch- and trouser pieces
- throttle valves
- adapters

$\varnothing 80 - \varnothing 400$ mm ducts are laser welded. Other sizes are longitudinally lock formed ducts.

Bends, branch pieces, shaped pieces etc are assembled with overlap and point-welded.

Ducts and shaped pieces are manufactured from hot dip galvanised steel sheet: Dogal 280, DX 51 D, DX 54 D or DX 56 D with material thickness from 0.75 mm – 1.25 mm.

Surface treatment class is Z 275 - i.e. zinc coating is minimum 275 g/m² double sided.

Pull rings [f.b] are used as standard joint assembly for rapid assembly and separation on $\varnothing 80$ mm to $\varnothing 800$ mm ducts, and loose flanges [f.b.m.fl] are used for $\varnothing 850$ mm to $\varnothing 1000$ mm ducts.

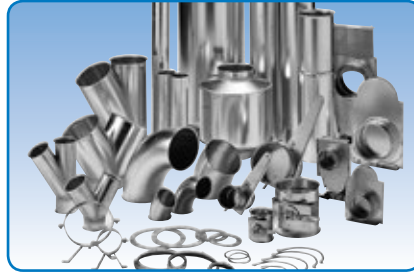

Laser welded and longitudinally lock formed duct system, galvanised



Sliding dampers, throttle valves

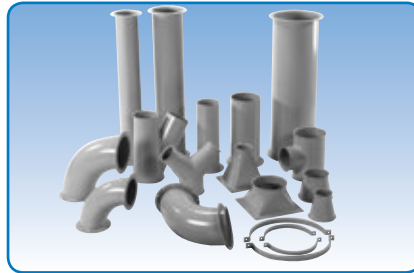

2 and 3 mm duct system

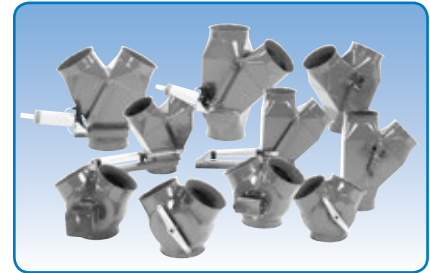

Diverters

2 and 3 mm duct system

The 2 and 3 mm system includes all components necessary for a complete and flexible extraction solution and can be used for particle transport, welding extraction etc.

- laser welded ducts
- plasma welded ducts
- pressed bends
- tight sliding dampers
- branch- and trouser pieces
- throttle valves
- diverters – pressed and welded
- adapters

The heavy duty sheet thickness means that this system is ideal for applications using high pressure or highly abrasive particles.

$\varnothing 80 - \varnothing 400$ mm ducts are laser welded. Other sizes are plasma welded. Bends, diverters, branch- and trouser pieces, shaped pieces etc are fully welded.

Ducts and shaped pieces are made of DC 01 or DOMEX 240 sheet metal with a thickness of 2 – 3 mm.

Pull rings [f.b] are used as standard joint assembly for rapid assembly and separation on

$\varnothing 80$ mm to $\varnothing 600$ mm ducts, and loose flanges [m.fl] are used for $\varnothing 650$ mm to $\varnothing 1000$ mm ducts.

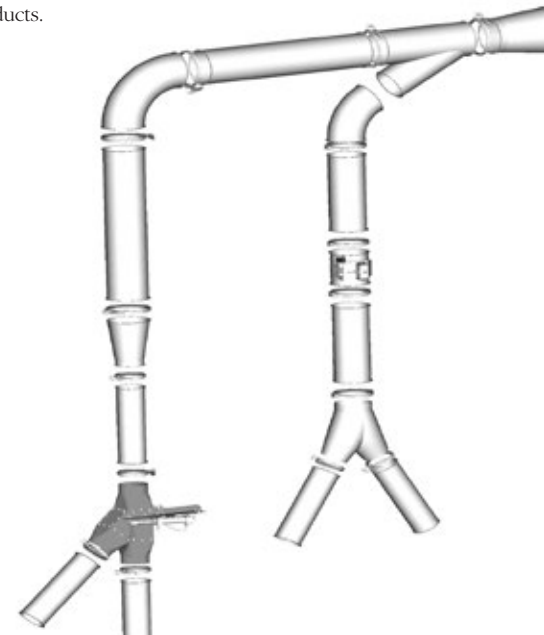

The duct system can be supplied with no surface treatment or powder coated with zinc primer and top coat paint. Standard colour is RAL 7032, but other colours and hot dip/electro-galvanised finishes are available at an additional price.

JKF Duct Systems

Surface treatment

JKF has installed a state-of-the art automatic 3-zone powder coating plant, which ensures high, uniform quality on all painted items (W0.5xH2.0xL1.0 m). A powder coating plant for larger items (W2.5xH2.5xL5.0 m) is used with integrated sandblasting facility. Powder application is manual.

Benefits of powder coating:

- High quality, impact and scratch-resistant surface
- High material usage - no evaporation
- Environment protection - no solvents

Standard surface treatment:

Filters, cyclones, fans, rotary valves, diverters:
3-step iron phosphate finish or sandblasting SA \geq 2.5/Ra 6-10 μ m

Powder coated with primer 60-80 μ m (Interpon BPP600) and top coat paint 60-80 μ m (Interpon D1036 Gloss (85)) RAL 5010
Expected service life in corrosive environments corresponding to C3 is up to 15 years.

Ducts and other parts for duct systems:

3-step iron phosphate finish or sandblasting SA \geq 2.5/Ra 6-10 μ m

Powder coated with top coat paint 60-80 μ m (Interpon D1036 Gloss (85)) RAL 7032
Expected service life in corrosive environments corresponding to C2 is up to 15 years.

Customised surface treatment

Sandblasting SA \geq 2.5/Ra 6-10 μ m.

Powder coated with primer 60-120 μ m (Interpon BPP600) and top coat paint

70-120 μ m (Interpon D1036 Gloss (85)) other RAL colours are available.
Expected service life in corrosive environments corresponding to C4 is up to 15 years.

Temperature range

Both duct systems can be used as standard at temperatures from -30°C to 80°C. Higher temperature tolerance available to order.

Tightness

Leaks in a duct system

mean loss of capacity and undesirable noise. The JKF duct systems are manufactured with minor tolerances, to ensure tight joints. Use of pull rings or rapid lock pull rings ensures that the duct section fulfills tightness class C, the best tightness class within industrial extraction.

Joint sealing compound or rubber flanges (EPDM) are recommended for flange assemblies to ensure tight joints. Correct assembly with sealing compound will result in assemblies which fulfil the requirements for tightness class C. See appendix 1 page 69.

Quality assurance

JKF's quality assurance system is certified according to DS/ISO9001 (DS/EN29001).



Jet- and rain caps



Pull rings, rapid lock pull rings, flanges



Accessories: Sanding tables, clip bands etc.

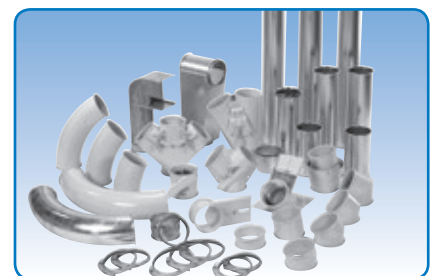

JK-6" duct system

Assembly methods, galvanised duct systems

Assembly methods

The high, uniform quality of JKF's duct systems along with efficient assembly and sealing ensures quick and easy assembly, with the ability to perform subsequent modifications.

The components for the galvanised duct system are made for a range of different assembly methods, which are also suitable for other systems.

Galvanised duct systems can be supplied to order for assembly with:

- pull rings [f.b]: $\varnothing 80 - \varnothing 500$ mm
- wide pull rings [f.bb]: $\varnothing 150 - \varnothing 1000$ mm
- rapid lock pull rings with handle [f.lyn]: $\varnothing 80 - \varnothing 400$ mm
- rapid lock pull rings with bolt [f.lyn]: $\varnothing 450 - \varnothing 800$ mm
- loose flanges [f.b.m.fl]: $\varnothing 80 - \varnothing 1000$ mm
- hoses [f.sl]: $\varnothing 80 - \varnothing 400$ mm
- smooth [g.l]: $\varnothing 80 - \varnothing 1000$ mm

The assembly method depends on duct dimensions, strength, tightness, noise and installation requirements.

Tightness can be increased when using $\varnothing 80 - \varnothing 300$ mm pull rings by fitting a U-shaped rubber gasket ring (EPDM) on the f.b. edge. Rapid lock pull rings have a fixed liner (EPDM), which ensures an airtight join.

Assembly method must be stated when placing order. Assembly methods are stated under the illustrations.

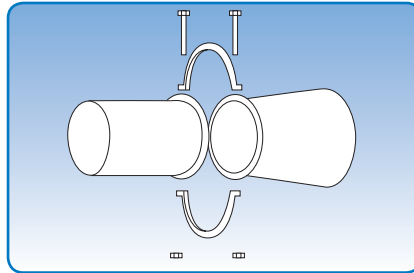

For pull rings [f.b]

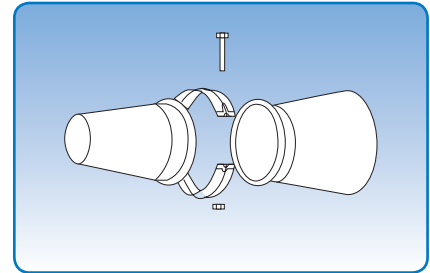

For wide pull rings [f.bb]

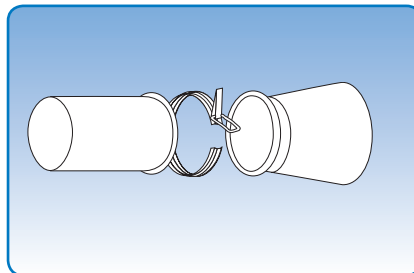

For rapid lock pull rings [f.lyn]

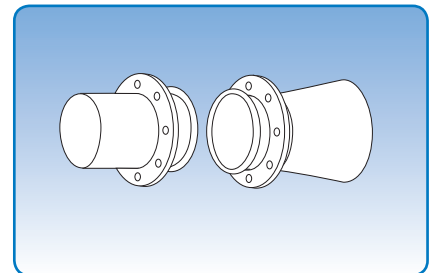

With loose flange fitted [f.b.m.fl]

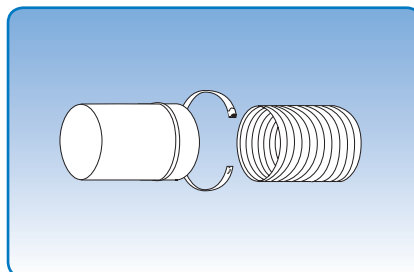

For hoses [f.sl]

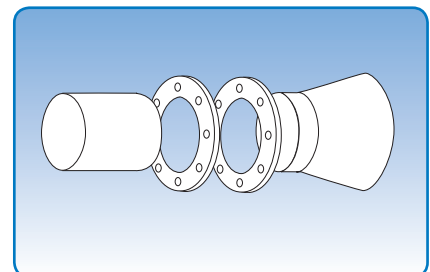

For flanges [f.fl]

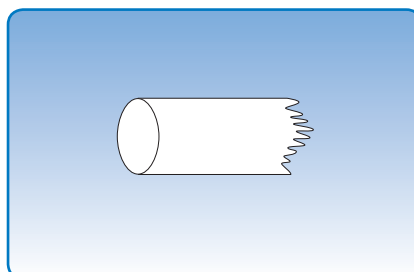

Smooth [g.l]

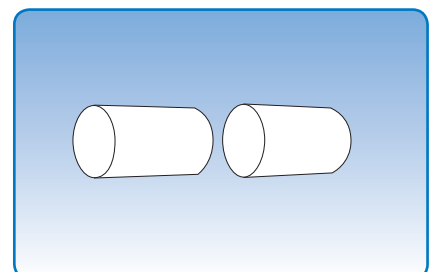

Conical [k]

Assembly methods, 2 and 3 mm duct systems

Assembly methods

The high, uniform quality of JKF's duct systems along with efficient assembly and sealing ensures quick and easy assembly, with the ability to perform subsequent modifications.

The components for 2 duct system are made for a range of different assembly methods, which are also suitable for other systems.

2 mm duct systems can be supplied to order for assembly with:

- 2 mm pull rings [f.b]:
 $\varnothing 80 - \varnothing 600$ mm
- rapid lock pull rings with handle [f.lyn]:
 $\varnothing 80 - \varnothing 400$ mm
- rapid lock pull rings with bolt [f.lyn]:
 $\varnothing 450 - \varnothing 600$ mm
- loose flanges [f.b.m.fl]: $\varnothing 80 - \varnothing 600$ mm
- welded flanges [m.fl]: $\varnothing 80 - \varnothing 1000$ mm
- direct flanges [d.fl]: $\varnothing 300 - \varnothing 1000$ mm

The assembly method depends on duct dimensions, strength, tightness, noise and installation requirements.

Tightness can be increased when using $\varnothing 80 - \varnothing 300$ mm pull rings by fitting a U-shaped rubber gasket ring (EPDM) on the f.b. edge. $\varnothing 315 - \varnothing 600$ mm pull rings can be supplied with integral seal at an additional price. Rapid lock pull rings have a fixed liner (EPDM), which ensures an airtight join.

Ducts with rapid lock pull rings, loose flanges or direct flanges assembly methods are fitted with a straight duct-shaped end piece with a length of min. 50 mm.

3 mm duct systems can be supplied to order for assembly with:

- rapid lock pull rings with-handle [f.lyn]:
 $\varnothing 150 - \varnothing 400$ mm
- rapid lock pull rings with bolt [f.lyn]:
 $\varnothing 450 - \varnothing 600$ mm
- welded flanges [m.fl]: $\varnothing 150 - \varnothing 1000$ mm

Assembly method must be stated when placing order. Assembly methods are stated under the illustrations.

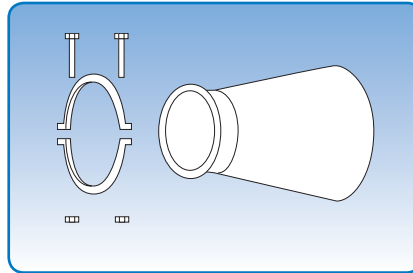

For pull rings [f.b]

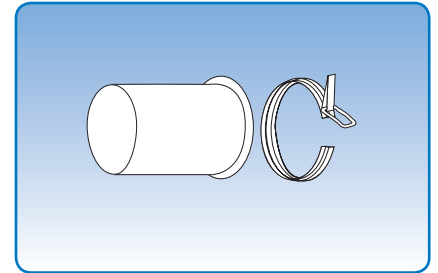

For rapid lock pull rings [f.lyn]

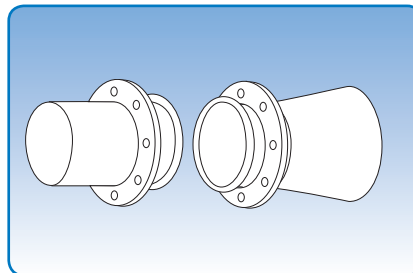

With loose flange fitted [f.b.m.fl]
 To max. $\varnothing 600$ mm diameter in 2.00 mm

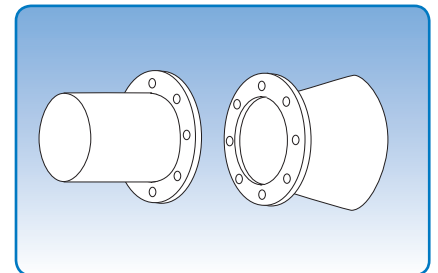

With welded flanges [m.fl]

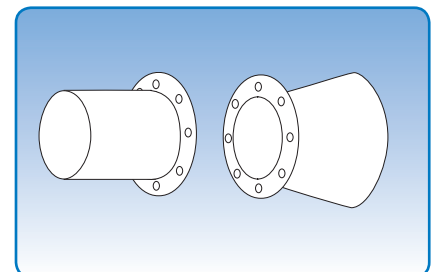

With direct flanges [d.fl]

Laser welded and longitudinally lock formed ducts, galvanised

Diameter: $\varnothing 80 - \varnothing 1000$ mm.

Laser welded and longitudinally lock formed ducts are galvanised and made from 0.75 mm, 0.90 mm or 1.00 mm sheet metal (s). Ducts are also available in 1.25 mm sheet metal.

Also available in other qualities and dimensions to order.

Ducts of up to $\varnothing 400$ mm diameter are supplied as standard laser welded in lengths of 0.5 m, 1.0 m and 2.0 m. Other sizes from $\varnothing 450$ mm diameter are supplied as longitudinally lock formed ducts in standard lengths of 0.5 m, 1.0 m and 2.0 m.

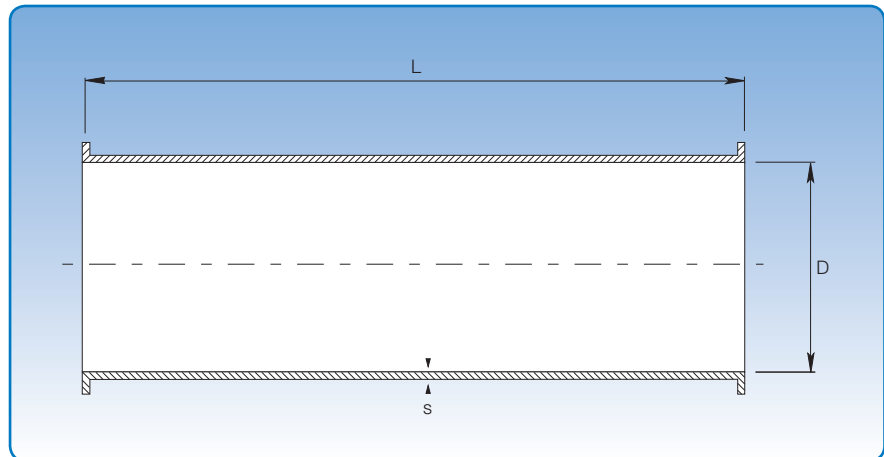

Dimensional specifications are given in the table below.

Dimensions							
D mm	s mm	Item no. L = 0.5 m	Weight at L = 0.5 m kg	Item no. L = 1.0 m	Weight at L = 1.0 m kg	Item no. L = 2.0 m	Weight at L = 2.0 m kg
Laser welded ducts							
80	0,75	10701091	0,80	10701191	1,60	10701291	2,90
100	0,75	10711091	1,00	10711191	2,00	10711291	3,70
120	0,75	10721091	1,20	10721191	2,40	10721291	4,40
125	0,75	10731091	1,25	10731191	2,50	10731291	4,60
140	0,75	10741091	1,40	10741191	2,80	10741291	5,10
150	0,75	10751091	1,50	10751191	3,00	10751291	5,50
160	0,75	10761091	1,60	10761191	3,20	10761291	5,80
180	0,75	10771091	1,75	10771191	3,50	10771291	6,70
200	0,75	10781091	2,00	10781191	4,00	10781291	7,20
225	0,75	10791091	2,25	10791191	4,50	10791291	8,20
250	0,75	10801091	2,50	10801191	5,00	10801291	9,00
275	0,75	108010199	2,75	108011199	5,50	108012199	11,00
300	0,75	10811091	2,85	10811191	5,70	10811291	11,00
315	0,75	10821091	3,00	10821191	6,00	10821291	12,00
350	0,75	10831091	3,25	10831191	6,50	10831291	13,00
375	0,75	10839091	3,25	10839191	6,50	10839291	13,00
400	0,90	10841091	4,50	10841191	9,00	10841291	18,00
Longitudinally lock formed ducts							
450	0,90	1085101	5,15	1085111	10,30	1085121	20,60
475	0,90	1085901	5,43	1085911	10,85	1085921	21,70
500	0,90	1086101	5,70	1086111	11,40	1086121	22,80
550	0,90	1087101	6,25	1087111	12,50	1087121	25,00
600	0,90	1088101	6,80	1088111	13,60	1088121	27,20
630	0,90	1089101	7,20	1089111	14,40	1089121	28,80
650	0,90	1090101	7,50	1090111	15,00	1090121	30,00
700	0,90	1091101	8,00	1091111	16,00	1091121	32,00
750	0,90	1092101	8,50	1092111	17,00	1092121	34,00
800	1,00	1093101	10,00	1093111	20,00	1093121	40,00
850	1,00	1094105	22,20	1094115	32,95	1094125	54,45
900	1,00	1095105	23,60	1095115	35,10	1095125	48,10
950	1,00	1096105	24,99	1096115	37,24	1096125	61,74
1000	1,00	1097105	26,38	1097115	39,38	1097125	65,38

Item numbers designated with $D \leq 800$ mm are for ducts assembled with pull rings [f.b]. Item numbers designated $D \geq 850$ mm are for ducts with loose flanges [f.b.m.fl].

Ducts are also available for other assembly methods. See p. 6 for assembly methods.

Telescopic ducts, galvanised

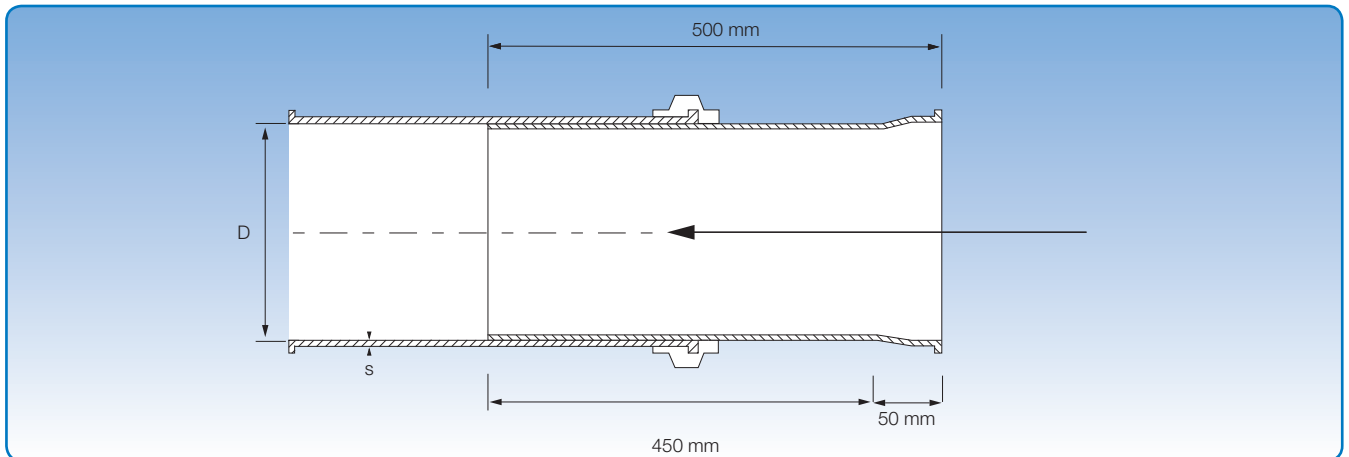

Dimensional specifications are given in the table below.

Diameter: $\varnothing 80$ - $\varnothing 500$ mm.

Telescopic ducts are made from 0.75 mm and 0.90 mm galvanised sheet metal and supplied with rapid lock pull rings, incl. rubber seal.

Item no.	Dimensions		Weight kg
	D mm	s mm	
1099389	80	0,75	0,99
1099394	100	0,75	1,20
1099401	120	0,75	1,39
1099411	125	0,75	1,45
1099421	140	0,75	1,60
1099431	150	0,75	1,70
1099441	160	0,75	1,80
1099451	180	0,75	2,07
1099461	200	0,75	2,29
1099471	225	0,75	2,53
1099481	250	0,75	2,78
1099491	275	0,75	3,07
1099501	300	0,75	3,37
1099511	315	0,75	3,58
1099521	350	0,75	3,95
1099531	400	0,90	5,00
1099541	450	0,90	5,70
1099551	500	0,90	6,30

The item numbers stated are for telescopic ducts assembled using pull rings [f.b].

Telescopic ducts are also available for other assembly methods. See p. 6 for assembly methods.

Ducts with access door, galvanised

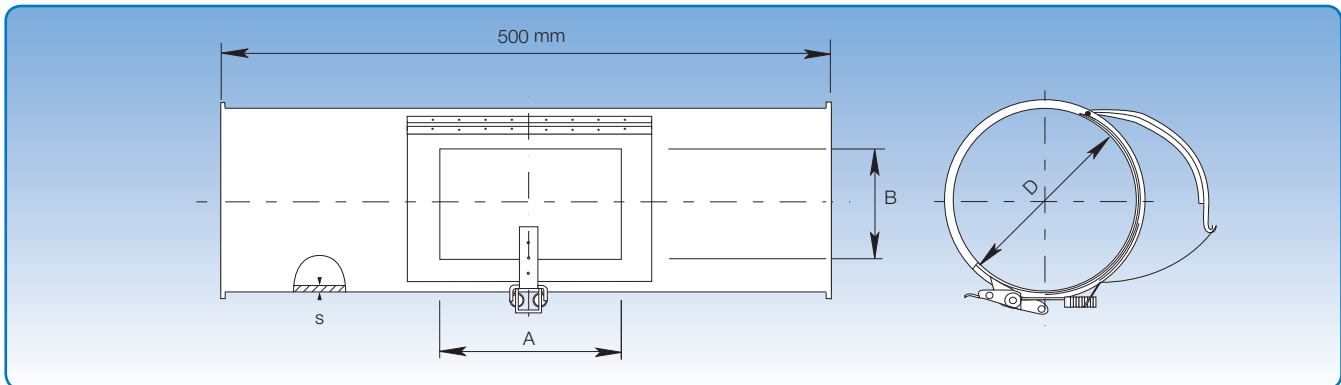

Dimensional specifications are given in the table below.

Diameter: $\varnothing 80 - \varnothing 1000$ mm.

Access doors are made of 1.25 mm galvanised sheet metal, such that the inside is smooth and has a close fit.

Item no.	Dimensions			Weight kg
	D mm	s mm	B x A mm	
4670371	80	0,90	80 x 150	0,80
4671371	100	0,90	100 x 150	1,00
4672371	120	0,90	100 x 150	1,20
4673371	125	0,90	100 x 150	1,25
4674371	140	0,90	100 x 150	1,40
4675371	150	0,90	100 x 150	1,50
4676371	160	0,90	100 x 150	1,60
4677371	180	0,90	100 x 150	1,75
4678371	200	0,90	100 x 150	2,00
4679371	225	0,90	100 x 150	2,25
4680371	250	0,90	100 x 150	2,50
4680379	275	0,90	100 x 150	2,65
4681371	300	0,90	100 x 150	2,85
4682371	315	0,90	100 x 150	3,00
4683371	350	0,90	150 x 200	3,25
4684371	400	0,90	150 x 200	4,50
4685371	450	0,90	150 x 200	5,15
4686371	500	0,90	150 x 200	5,70
4687371	550	0,90	150 x 200	6,25
4688371	600	0,90	150 x 200	6,80
4689371	630	0,90	150 x 200	7,20
4690371	650	0,90	150 x 200	7,50
4691371	700	0,90	150 x 200	8,00
4692371	750	0,90	150 x 200	8,50
4693371	800	1,00	150 x 200	10,00
4694371	850	1,00	150 x 200	10,75
4695371	900	1,00	150 x 200	11,50
4696371	950	1,00	150 x 200	12,25
4697371	1000	1,00	150 x 200	13,00

Item numbers designated with $D \leq 800$ mm are for ducts assembled with pull rings [f.b]. Item numbers designated $D \geq 850$ mm are for ducts with loose flanges [f.b.m.fl].

Ducts with access doors are also available for other assembly methods. See p. 6 for assembly methods.

Ducts with cleaning spigot, galvanised

Diameter: $\varnothing 100$ - $\varnothing 400$ mm.

The PVC cover is easy to fit and remove.
All cleaning spigots have a $\varnothing 100$ mm opening.

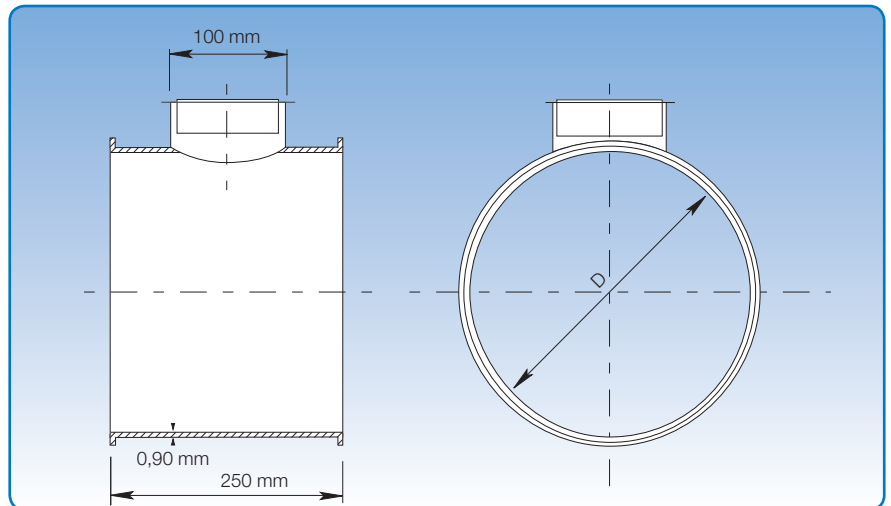

Dimensional specifications are given in the table below.

Item no.	Dimensions		Weight kg
	D mm		
4671101	100		0,50
4671102	120		0,60
4671103	125		0,65
4671104	140		0,70
4671105	150		0,75
4675101	160		0,80
4675102	180		0,85
4675103	200		1,00
4675104	225		1,15
4675105	250		1,25
4675106	275		1,35
4680101	300		1,45
4680102	315		1,50
4680103	350		1,65
4680104	400		2,25

The item numbers stated are for ducts with cleaning spigots assembled using pull rings [f.b].

Ducts with cleaning spigots are also available for other assembly methods. See p. 6 for assembly methods.

Pressed bends, galvanised

Diameter: $\varnothing 80 - \varnothing 400$ mm.

Galvanised bends are made of 1.00 mm sheet metal.

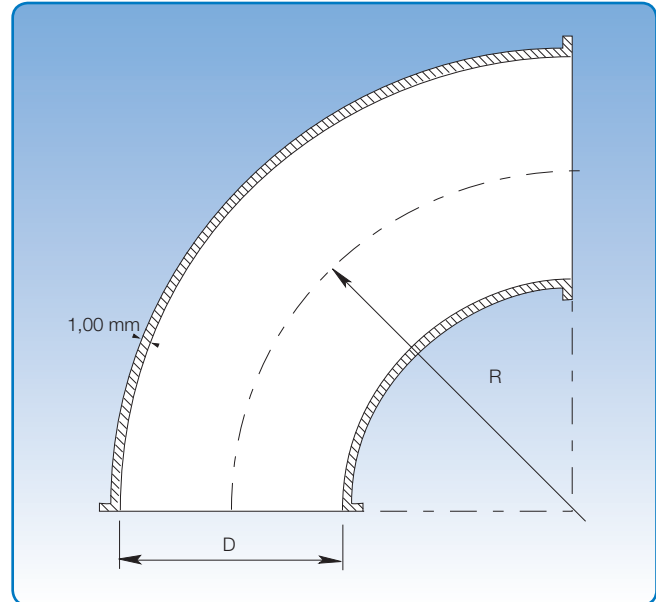

Dimensional specifications are given in the table below. Diameter = (D).
 $R = 1.5 \times D$ for all dimensions.

When replacing the galvanized bend with 2 – 3.00 mm bend, there may be tolerance differences of ± 20 mm.

D mm	Dimensions											
	90°		60°		45°		30°		15°		7.5°	
	Item no.	kg	Item no.	kg	Item no.	kg	Item no.	kg	Item no.	kg	Item no.	kg
80	1170192	0,44	1170162	0,24	1170142	0,20	1170132	0,12	1170112	0,10	1170102	0,10
100	1171192	0,62	1171162	0,40	1171142	0,30	1171132	0,20	1171112	0,14	1171102	0,13
120	1172192	0,90	1172162	0,60	1172142	0,40	1172132	0,30	1172112	0,18	1172102	0,16
125	1173192	0,90	1173162	0,65	1173142	0,45	1173132	0,32	1173112	0,18	1173102	0,18
140	1174192	1,10	1174162	0,80	1174142	0,55	1174132	0,40	1174112	0,24	1174102	0,20
150	1175192	1,50	1175162	0,90	1175142	0,70	1175132	0,50	1175112	0,25	1175102	0,20
160	1176192	1,70	1176162	1,10	1176142	0,80	1176132	0,50	1176112	0,30	1176102	0,29
180	1177192	2,00	1177162	1,30	1177142	1,00	1177132	0,70	1177112	0,40	1177102	0,30
200	1178192	2,50	1178162	1,85	1178142	1,25	1178132	1,00	1178112	0,50	1178102	0,35
225	1179192	3,00	1179162	2,00	1179142	1,60	1179132	1,20	1179112	0,60	1179102	0,37
250	1180192	4,00	1180162	3,00	1180142	2,00	1180132	1,50	1180112	0,75	1180102	0,50
275	11801929	4,80	11801629	3,60	11801429	2,40	11801329	1,80	11801129	0,80	11801029	0,55
300	1181192	5,90	1181162	3,90	1181142	2,90	1181132	2,00	1181112	0,90	1181102	0,60
315	1182192	5,90	1182162	3,80	1182142	2,95	1182132	2,00	1182112	1,12	1182102	0,55
350	1183192	7,30	1183162	4,80	1183142	3,70	1183132	2,55	1183112	1,30	1183102	1,00
400	1184192	10,20	1184162	6,70	1184142	5,10	1184132	3,60	1184112	1,60	1184102	1,20

The item numbers stated are for bends assembled using pull rings [f.b].

Bends are also available for other assembly methods. See p. 6 for assembly methods.

Segment bends, galvanised

Diameter: $\varnothing 450$ - $\varnothing 1000$ mm.

Galvanised segment bends are made from 0.90 mm and 1.00 mm sheet metal (s).

They are available in other radii and dimensions to order.

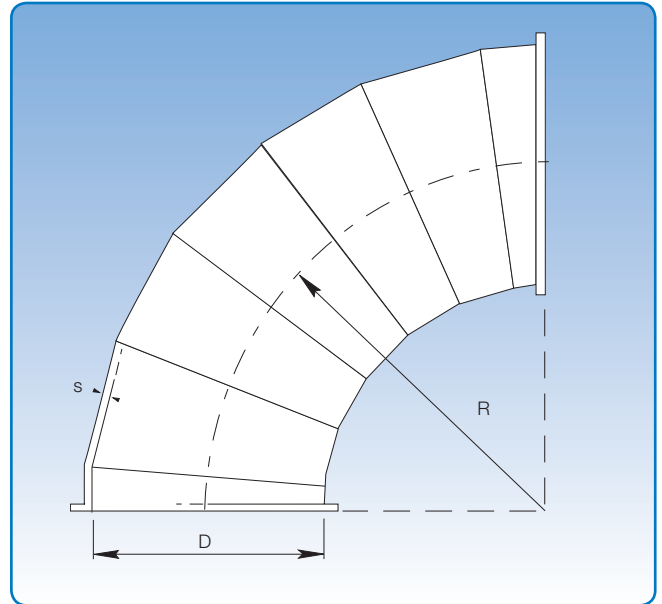

Dimensional specifications are given in the table below.
 $R = 1.5 \times D$ for all dimensions.

Dimensions													
D mm	s mm	90°		60°		45°		30°		15°		7.5°	
		Item no.	kg	Item no.	kg	Item no.	kg	Item no.	kg	Item no.	kg	Item no.	kg
450	0,90	1185792	12,00	1185762	9,00	1185742	6,00	1185732	4,50	1185712	2,25	1185702	1,10
500	0,90	1186792	15,00	1186762	11,20	1186742	7,50	1186732	5,60	1186712	2,80	1186702	1,40
550	0,90	1187792	18,00	1187762	13,50	1187742	9,00	1187732	6,80	1187712	3,40	1187702	1,70
600	0,90	1188792	21,50	1188762	16,10	1188742	10,75	1188732	8,05	1188712	4,00	1188702	2,00
630	0,90	1189792	22,40	1189762	16,80	1189742	11,20	1189732	8,40	1189712	4,20	1189702	2,10
650	0,90	1190792	25,00	1190762	18,80	1190742	12,50	1190732	9,40	1190712	4,70	1190702	2,35
700	0,90	1191792	29,00	1191762	21,80	1191742	14,50	1191732	10,90	1191712	5,40	1191702	2,70
750	0,90	1192792	33,00	1192762	24,80	1192742	16,50	1192732	12,40	1192712	6,20	1192702	3,10
800	1,00	1193792	37,50	1193762	28,10	1193742	18,75	1193732	14,05	1193712	7,00	1193702	3,50
850	1,00	1194792	42,50	1194762	32,00	1194742	21,25	1194732	16,00	1194712	8,00	1194702	4,00
900	1,00	1195792	48,00	1195762	36,00	1195742	24,00	1195732	18,00	1195712	9,00	1195702	4,50
950	1,00	1196792	53,00	1196762	39,80	1196742	26,50	1196732	20,00	1196712	10,00	1196702	5,00
1000	1,00	1197792	59,00	1197762	44,00	1197742	29,50	1197732	22,00	1197712	11,00	1197702	5,50

Item numbers designated $D \leq 800$ mm are for segment bends assembled using pull rings [f.b]. Item numbers designated $D \geq 850$ mm are for ducts with loose flanges [f.b.m.fl].

Segment bends are also available for other assembly methods. See p. 6 for assembly methods.

30° straight branch pieces, galvanised

Diameter: ø80 – ø1000 mm.

Galvanised branch pieces are made of 0.90 mm sheet metal.

When assembled with loose flanges, [f.b.m.fl], L1 is extended by 2 x 50 mm.

State A-, B- and C dimensions when ordering.
Options are limited by A = C, and A ≥ B.
A = C must be max. 1000 mm.

The branch determines the length of L1.
Branch pieces are always straight with the branch centrally located.

L1, L2 and L3 can be calculated using the stated formulas.

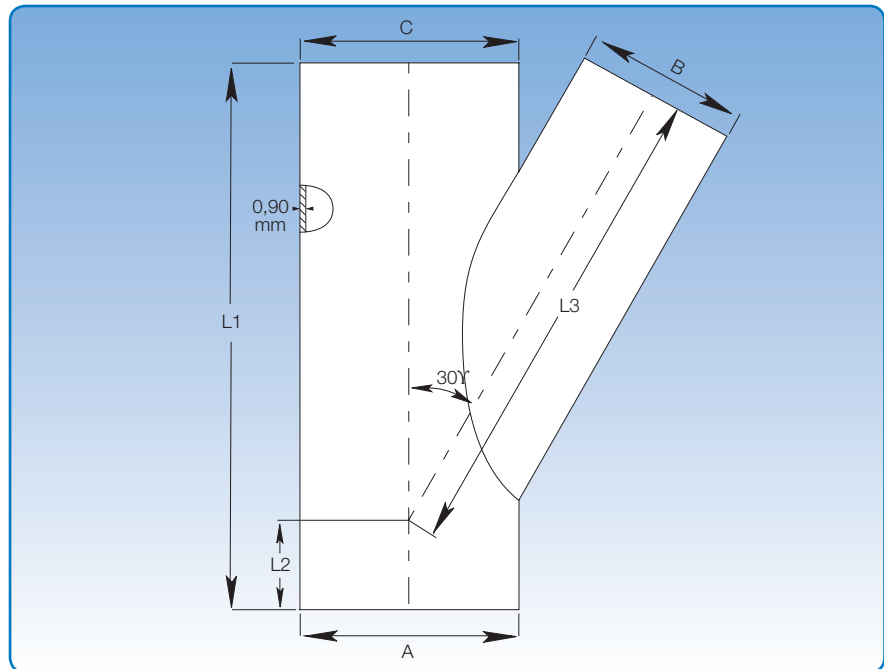

Calculating L2 and L3:

L1 = see table

$$L2 = \frac{1}{2} \times \left(L1 - \frac{A}{\tan \alpha} \right)$$

$$L3 = \frac{L1 - L2}{\cos \alpha} \times \tan \left(\frac{B}{A} \right)$$

Example:

A = 650, B = 400, C = 650

L1 = 1050 mm

$$L2 = 0,5 \times \left(1050 - \frac{650}{\tan 29,7} \right) = 0,5 \times (1050 - 1139,57)$$

L2 = - 44,79 ~ - 45 mm

$$L3 = \frac{1050 + 45}{\cos 29,7} \times \left(\frac{400}{650} \times \tan 29,7 \right) = 1260,60 - 114,08$$

L3 = 1146,52 ~ 1147 mm

Dimensions						
A = C mm	B mm	L1 mm	L2 mm	L3 mm	∞	
Select (80 - 1000)	80	350			28,0	
	100	350			28,8	
	120	350			28,8	
	125	400			29,0	
	140	450			29,1	
	150	450			29,2	
	160	450			29,2	
	180	550			29,3	
	200	550			29,3	
	225	600			29,4	
	250	750			29,5	
	275	750		Calculate	Calculate	29,6
	300	750				29,6
	315	850				29,6
	350	950				29,6
	400	1050				29,7
	450	1250				29,7
	500	1250				29,7
	550	1450				29,8
	600	1450				29,8
630	1650				29,8	
650	1650				29,8	
700	1650				29,8	
750	1850				29,9	
800	1850				29,9	
850	2050				29,9	
900	2050				29,9	

45° straight branch pieces, galvanised

Diameter: ø80 – ø1000 mm.

Galvanised branch pieces are made of 0.90 mm sheet metal.

When supplied with loose flanges, [f.b.m.fl], L1 is extended by 2 x 50 mm.

State A-, B- and C dimensions when ordering.
Options are limited by A = C, and A ≥ B.
A = C must be max. 1000 mm.

The branch determines the length of L1.
Branch pieces are always straight with the branch centrally located.

L1, L2 and L3 can be calculated using the stated formulas.

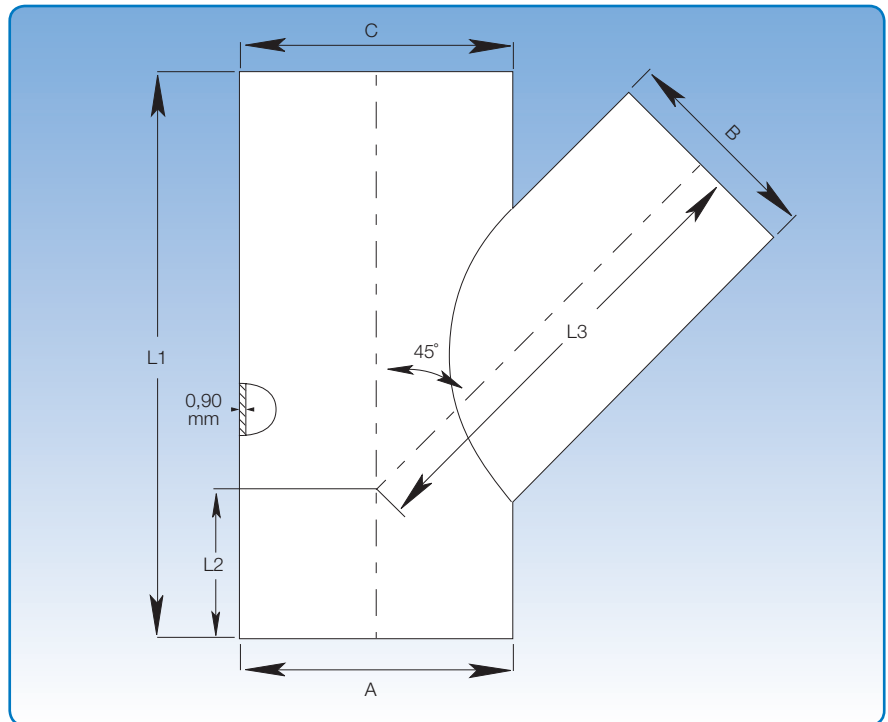

Calculating L2 and L3:

L1 = see table

$$L2 = \frac{1}{2} \times \left(L1 - \frac{A}{\text{tg} \alpha} \right)$$

$$L3 = \frac{L1 - L2}{\cos \alpha} - \left(\frac{B}{2} \times \text{tg} \alpha \right)$$

Example:

A = 500, B = 450, C = 500

L1 = 950 mm

$$L2 = 0,5 \times \left(950 - \frac{500}{\text{tg} 44,7} \right) = 0,5 \times (950 - 505,26)$$

L2 = - 222,37 ~ - 222 mm

$$L3 = \frac{950 + 222}{\cos 44,7} - \left(\frac{450}{2} \times \text{tg} 44,7 \right) = 1024,19 - 222,66$$

L3 = 801,53 ~ 802 mm

Dimensions					
A = C mm	B mm	L1 mm	L2 mm	L3 mm	α
	80	300			43,8
	100	300			43,8
	120	350			44,0
	125	350			44,0
	140	350			44,1
	150	400			44,2
	160	400			44,2
	180	400			44,3
	200	450			44,4
	225	500			44,5
	250	500			44,5
	275	600			44,6
	300	600	Calculate	Calculate	44,6
	315	600			44,6
	350	700			44,7
	400	800			44,7
	450	950			44,7
	500	950			44,8
	550	1150			44,8
	600	1050			44,8
	630	1150			44,8
	650	1150			44,8
	700	1300	44,8		
	750	1300	44,8		
	800	1450	44,9		
	850	1450	44,9		
	900	1650	44,9		

30° conical branch pieces, galvanised

Diameter A: ø100 - ø1000 mm.

Galvanised branch pieces are made of 0.90 mm sheet metal.

L1 will be extended by 2 x 50 mm if the branch piece is supplied with loose flanges [f.b.m.fl], rapid lock pull rings [f.lyn] or wide pull rings [f.bb].

State branch piece A, B- and C dimensions when ordering. A, B and C can be combined to order; although branch B determines length L1 as stated in the table.

Maximum diameter reduction between A and C is 200 mm. For B applies: $B < (A+C)/2$.

The largest branch will determine L1 for double branch pieces.

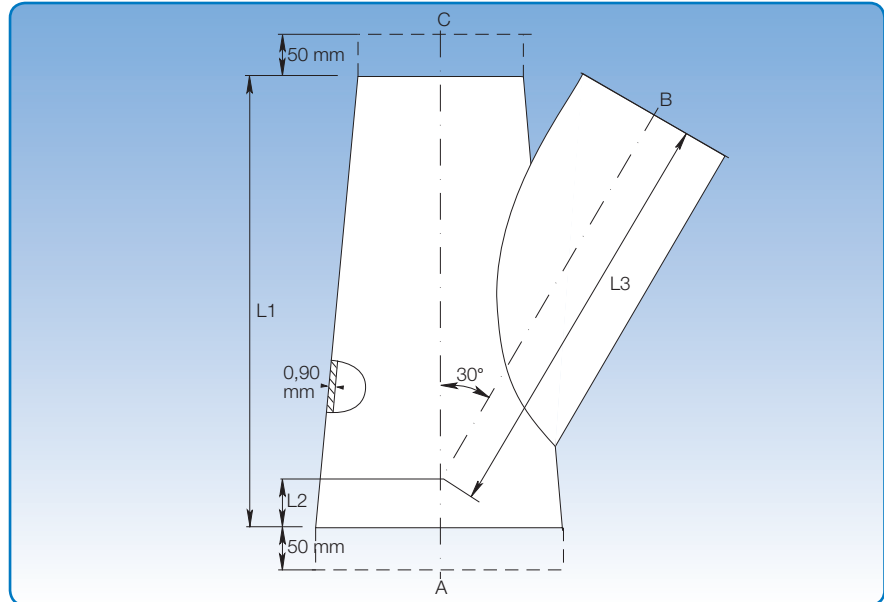

Calculating L2 and L3:

L1 = See table

$$L2 = \left(\frac{L1}{2} \right) - \left(\frac{A + C}{4 \times \text{tg}\alpha} \right)$$

$$L3 = \left(\frac{L1 - L2}{\cos\alpha} \right) - \left(\frac{B}{2} \times \text{tg}\alpha \right)$$

Example:

A = 650, B = 500, C = 450

L1 = 1250 mm

$$L2 = \frac{1250}{2} - \left(\frac{650 + 450}{4 \times \text{tg} 29,7} \right) = 625 - 476,31$$

L2 = 142,87 ~ 143 mm

$$L3 = \frac{1250 - 143}{\cos 29,7} - \left(\frac{500}{2} \times \text{tg} 29,7 \right) = 1274,42 - 142,60$$

L3 = 1131,82 ~ 1132 mm

Dimensions						
A mm	B mm	C mm	L1 mm	L2 mm	L3 mm	∞
	80		350			28,0
	100		350			28,8
	120		350			28,8
	125		400			29,0
	140		450			29,1
	150		450			29,2
	160		450			29,2
	180		550			29,3
	200		550			29,3
Select (100 - 1000)	225	Select (100 - 1000)	600			29,4
	250		750			29,5
	275		750	Calculate	Calculate	29,6
	300		750			29,6
	315		850			29,6
	350		950	Calculate	Calculate	29,6
	400		1050			29,7
	450		1250			29,7
	500		1250			29,7
	550		1250			29,8
600	1450			29,8		
630	1650			29,8		
650	1650			29,8		
700	1650			29,8		
750	1850			29,9		
800	1850			29,9		
850	2050			29,9		
900	2050			29,9		

45° conical branch pieces, galvanised

Diameter A: ø100 - ø1000 mm.

Galvanised branch pieces are made of 0,90 mm sheet metal.

L1 will be extended by 2 x 50 mm if the branch piece is supplied with loose flanges [f.b.m.fl], rapid lock pull rings [f.lyn] or wide pull rings [f.bb].

State branch piece A-, B- and C dimensions when ordering. A, B and C can be combined to order; although branch B determines length L1 as stated in the table.

Maximum diameter reduction between A and C is 200 mm. For B applies: $B < (A+C)/2$.

The largest branch will determine L1 for double branch pieces.

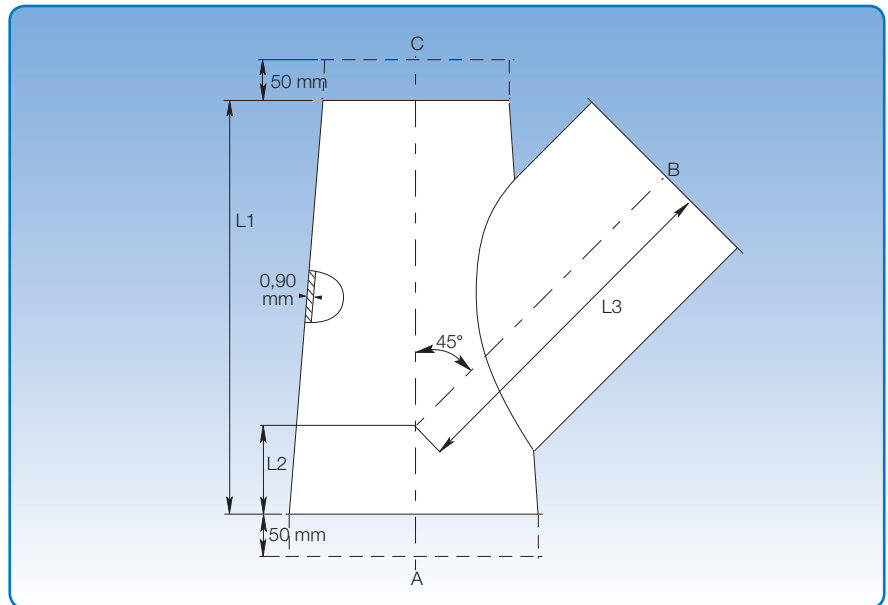

Calculating L2 and L3:

L1 = See table

$$L2 = \left(\frac{L1}{2} \right) - \left(\frac{A + C}{4 \times \text{tg}\alpha} \right)$$

$$L3 = \left(\frac{L1 - L2}{\cos\alpha} \right) - \left(\frac{B}{2} \times \text{tg}\alpha \right)$$

Example:

A = 500, B = 300, C = 350

L1 = 600 mm

$$L2 = \frac{600}{2} - \left(\frac{500 + 350}{4 \times \text{tg} 44,6} \right) = 300 - 215,49$$

L2 = 84,51 ~ 85 mm

$$L3 = \frac{600 - 85}{\cos 44,6} - \left(\frac{300}{2} \times \text{tg} 44,6 \right) = 723,29 - 149,92$$

L3 = 575,37 ~ 575 mm

Dimensions						
A mm	B mm	C mm	L1 mm	L2 mm	L3 mm	α
	80		300			43,8
	100		300			43,8
	120		350			44,0
	125		350			44,0
	140		350			44,1
	150		400			44,2
	160		400			44,2
	180		400			44,3
	200		450			44,4
Select (100 - 1000)	225	Select (100 - 1000)	500	Calculate	Calculate	44,5
	250		500			44,5
	275		600			44,6
	300		600			44,6
	315		600			44,6
	350		700			44,7
	400		800			44,7
	450		950			44,7
	500		1050			44,8
	550		1150			44,8
600	1150	44,8				
630	1150	44,8				
650	1150	44,8				
700	1300	44,8				
750	1300	44,8				
800	1450	44,9				
850	1450	44,9				
900	1650	44,9				

30° branch plates, galvanised

Diameter: ø80 – ø1000 mm.

Galvanised branch plates are made of 0.90 mm sheet metal.

State A-, B- and C dimensions when ordering.

Options are limited by $A = C$, and $A \geq B$.

$A = C$ must be max. 1000 mm.

The branch determines the length of L1.

Branch plates are always straight with the branch centrally located.

If $B < 300$: $X = 50$ mm

If $B > 300$: $X = 100$ mm

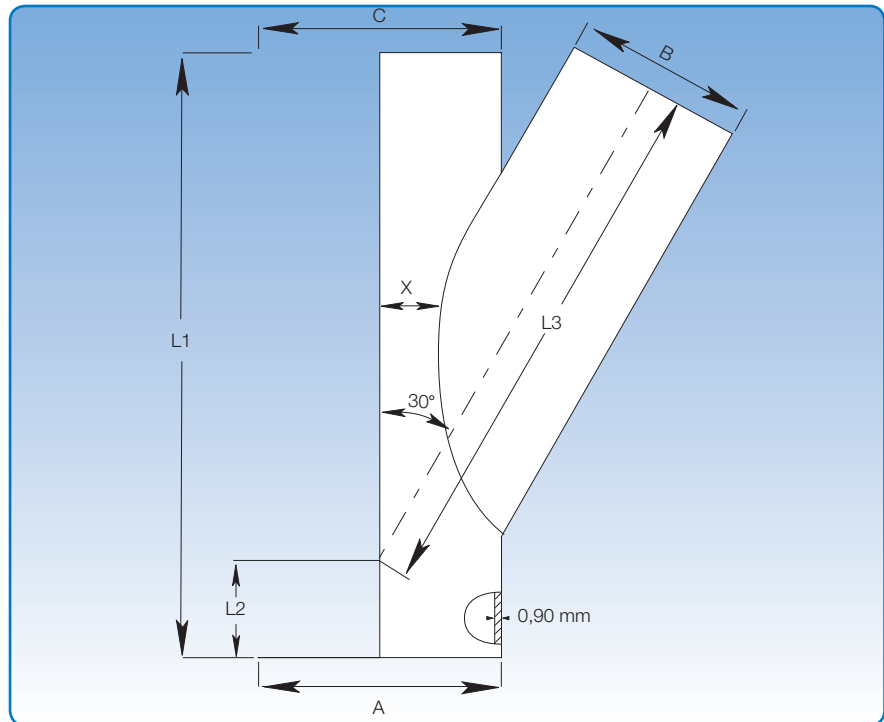

Calculating L2 and L3:

$L1 =$ see table

$$L2 = \frac{1}{2} \times \left(L1 - \frac{A}{\text{tg} 30^\circ} \right)$$

$$L3 = \frac{L1 - L2}{\cos 30^\circ} - \left(\frac{B}{2} \times \text{tg} 30^\circ \right)$$

Example:

$A = 700$, $B = 350$, $C = 700$

$L1 = 950$ mm

$$L2 = 0,5 \times \left(950 - \frac{700}{\text{tg} 29,6^\circ} \right) = 0,5 \times (950 - 1232,22)$$

$L2 = -141,11 \sim -141$ mm

$$L3 = \frac{950 + 141}{\cos 29,6^\circ} - \left(\frac{350}{2} \times \text{tg} 29,6^\circ \right) = 1254,75 - 99,41$$

$L3 = 1155,34 \sim 1155$ mm

Dimensions					
A = C mm	B mm	L1 mm	L2 mm	L3 mm	∞
Select (80 - 1000)	80	350			28,0
	100	350			28,8
	120	350			28,8
	125	400			29,0
	140	450			29,1
	150	450			29,2
	160	450			29,2
	180	550			29,3
	200	550			29,3
	225	600			29,4
	250	750			29,5
	275	750			29,6
	300	750			29,6
	315	850			29,6
	350	950			29,6
	400	1050			29,7
	450	1250			29,7
	500	1250			29,7
	550	1450			29,8
	600	1450			29,8
650	1650			29,8	
700	1650			29,8	
750	1850			29,8	
800	1850			29,9	
850	2050			29,9	
900	2050			29,9	
			Calculate	Calculate	

45° branch plates, galvanised

Diameter: ø80 – ø1000 mm.

Galvanised branch plates are made of 0.90 mm sheet metal.

State A-, B- and C dimensions when ordering.
Options are limited by $A = C$, and $A \geq B$.
 $A = C$ must be max. 1000 mm.

The branch determines the length of L1.
Branch plates are always straight with the branch centrally located.

If $B < 300$: $X = 50$ mm
If $B > 300$: $X = 100$ mm

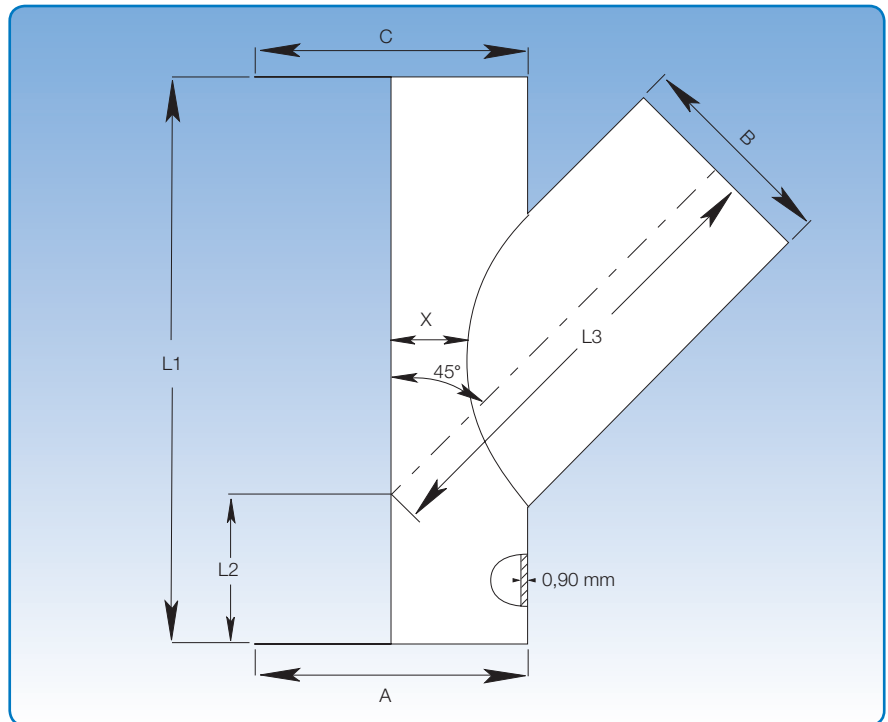

Calculating L2 and L3:

$L1 =$ see table

$$L2 = \frac{1}{2} \times \left(L1 - \frac{A}{\tan 45^\circ} \right)$$

$$L3 = \frac{L1 - L2}{\cos 45^\circ} - \left(\frac{B}{2} \times \tan 45^\circ \right)$$

Example:

$A = 550, B = 500, C = 550$

$L1 = 1050$ mm

$$L2 = 0,5 \times \left(1050 - \frac{550}{\tan 44,8} \right) = 0,5 \times (1050 - 550)$$

$L2 = 248,07 \sim 248$ mm

$$L3 = \frac{1050 - 248}{\cos 44,8} - \left(\frac{500}{2} \times \tan 44,8 \right) = 1130,26 - 248,26$$

$L3 = 882$ mm

Dimensions					
A = C mm	B mm	L1 mm	L2 mm	L3 mm	∞
Select (80 - 1000)	80	300	Calculate	Calculate	43,8
	100	300			43,8
	120	350			44,0
	125	350			44,0
	140	350			44,1
	150	400			44,2
	160	400			44,2
	180	400			44,3
	200	450			44,4
	225	500			44,5
	250	500			44,5
	275	600			44,6
	300	600			44,6
	315	600			44,6
	350	700			44,7
	400	800			44,7
	450	950			44,7
	500	1050			44,8
	550	1150			44,8
	600	1150			44,8
650	1150	44,8			
700	1300	44,8			
750	1300	44,8			
800	1450	44,8			
850	1450	44,9			
900	1650	44,9			

30° and 45° trouser pieces, galvanised

Diameter: $\varnothing 80 - \varnothing 1000$ mm.

Galvanised trouser pieces are made of 0,90 mm sheet metal.

State A-, B- and C dimensions when ordering.

Trouser pieces are extended by 50 mm on legs B and C when assembled by wide pull rings [f.bb], rapid lock pull rings [f.lyn], or loose flanges [f.b.m.fl].

JKF can also supply trouser pieces in other angles and qualities.

For galvanised trouser pieces:

$A \geq B$ and $A \geq C$. When $C \neq B$, the highest value of B and C shall be used for calculation.

Calculation of L1 and L2 for 2 × 30°:

$$L1 = (A \times 0,134) + 50$$

$$L2 = (B \times 0,866) + 100$$

Example:

$$A = B = C = 200$$

$$L1 = (200 \times 0,134) + 50 = 76,8$$

$$L2 = (200 \times 0,866) + 100 = 273,2$$

Calculation of L1 and L2 for 2 × 45°:

$$L1 = (A \times 0,207) + 50$$

$$L2 = (B \times 0,5) + 100$$

Example:

$$A = B = C = 200$$

$$L1 = (200 \times 0,207) + 50 = 91,4$$

$$L2 = (200 \times 0,5) + 100 = 200$$

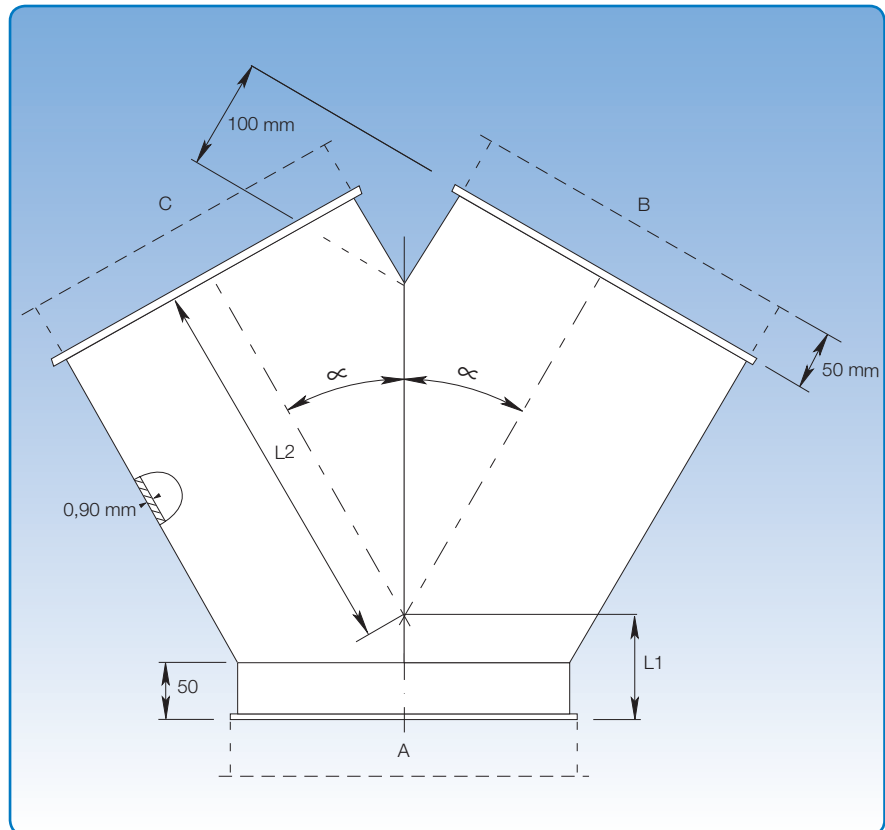

$\alpha = 30^\circ$ or 45°

90° T-pieces, galvanised

Diameter: $\varnothing 80 - \varnothing 1000$ mm.

Galvanised T-pieces are made of 0.90 - 1.00 mm sheet metal (s).

Dimensions: $A=C \geq B$.

State A-, B- and C dimensions when ordering.

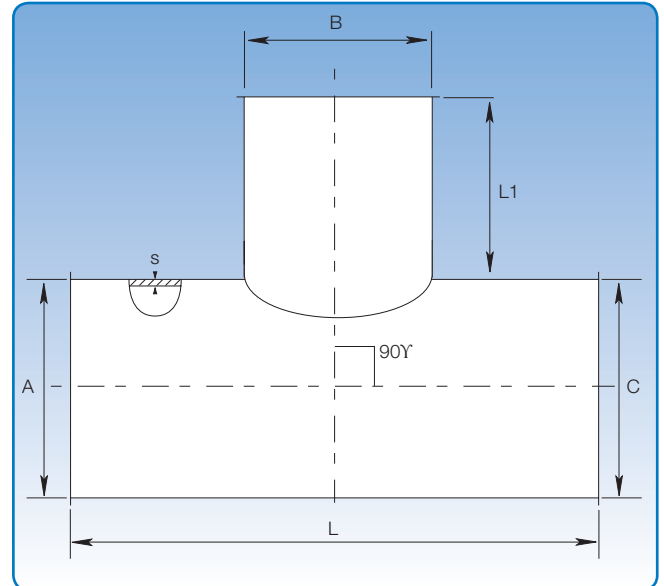

Dimensional specifications are given in the table below.

Dimensions			
B mm	s mm	L mm	L1 mm
80	0,90	230	75
100	0,90	250	75
120	0,90	270	75
125	0,90	275	75
140	0,90	290	75
150	0,90	300	75
160	0,90	310	75
180	0,90	330	75
200	0,90	350	75
225	0,90	425	100
250	0,90	450	100
275	0,90	475	100
300	0,90	500	100
315	0,90	515	100
350	0,90	550	100
400	0,90	600	100
450	0,90	750	150
500	0,90	800	150
550	0,90	850	150
600	0,90	900	150
630	0,90	930	150
650	0,90	950	150
700	0,90	1100	200
750	0,90	1150	200
800	1,00	1200	200
850	1,00	1250	200
900	1,00	1300	200
950	1,00	1350	200
1000	1,00	1400	200

Tapers, galvanised

Diameter: $\varnothing 80 - \varnothing 1000$ mm.

Tapers are spot welded and made of 0.90 mm galvanised sheet metal.

When assembling with wide pull rings [f.bb], rapid lock pull rings [f.lyn] and loose flanges [f.b.m.fl] length (L) is increased by 2×50 mm.

State D- and d dimensions when ordering.
Length L is stated in the table below.

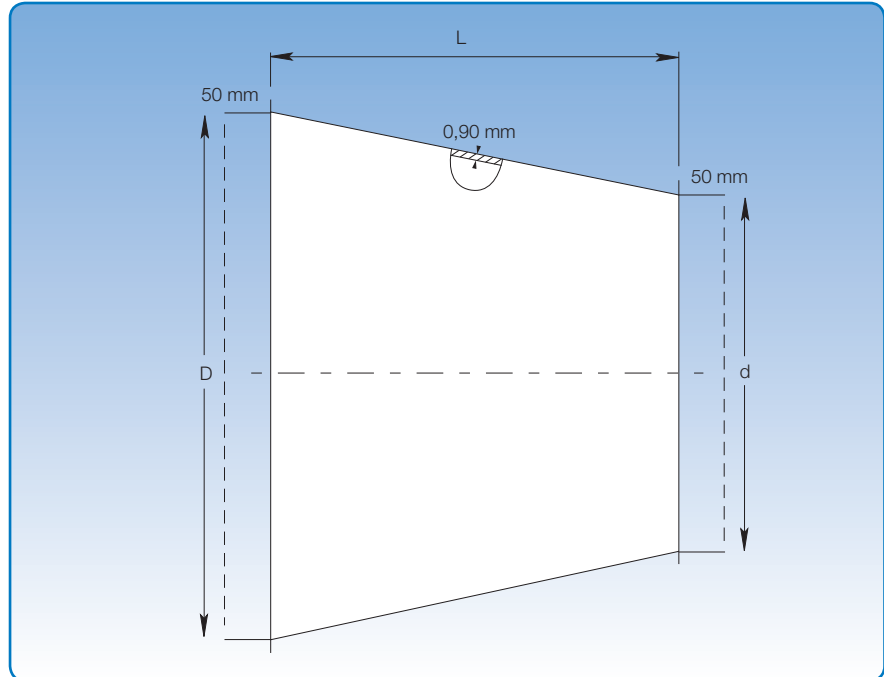

Determining taper length L:

The difference between the larger and smaller diameter (D - d) is plotted on the vertical axis of the coordinate system. By following the line from this point to the intersection, the length (L) can be read at the corresponding point on the horizontal axis.

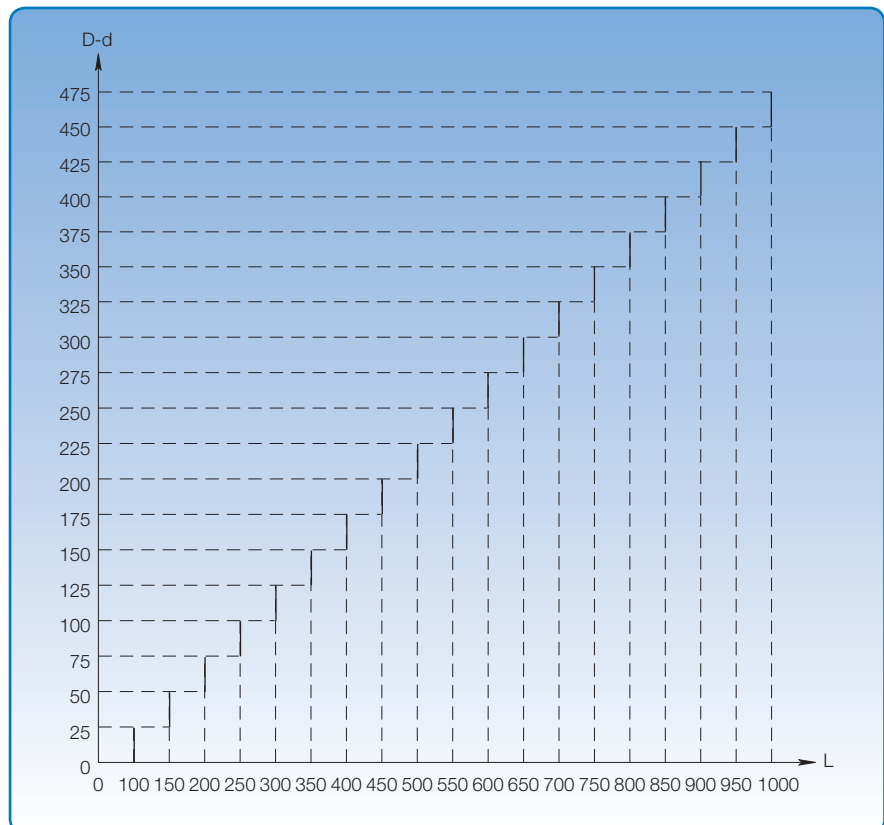

Transition pieces, galvanised

Diameter: $\varnothing 80 - \varnothing 1000$ mm.

Transition pieces are spot welded and made of 0.90 mm galvanised sheet metal.

Transition pieces can be made to order in other dimensions, and can be made asymmetrical.

State dimensions for BU \times LU and D plus assembly method when ordering (p. 6).

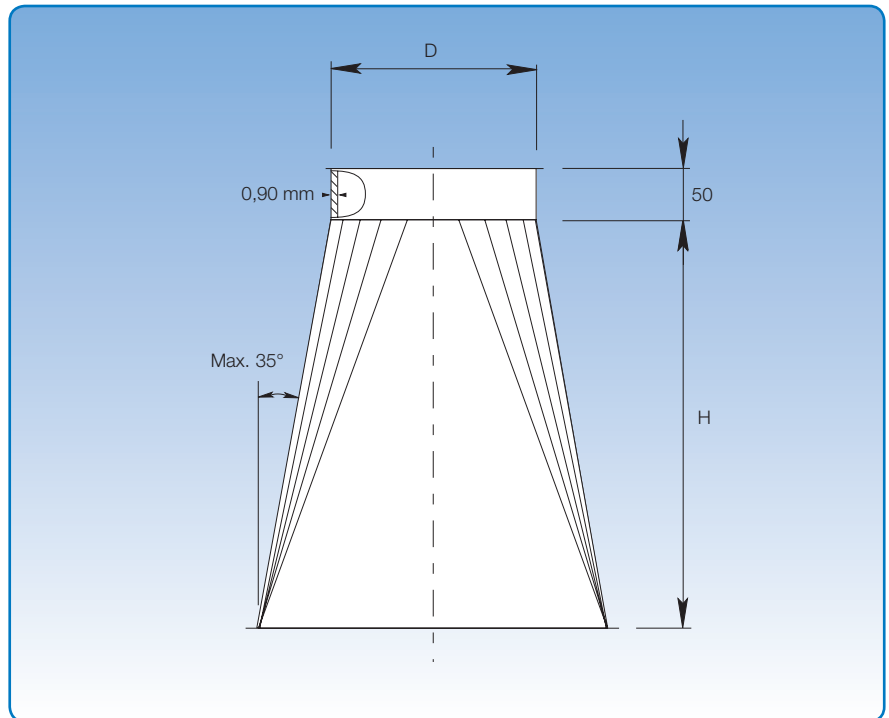

Calculating H:

$$H = 240 + 0,5 \times (\text{max. value of LU} - D) \text{ or } (BU - D)$$

Example

$$D = 350, LU = 400, BU = 600, EXL = 200, EXB = 300$$

$$H = 240 + (0,5 \times 250) = 240 + 125$$

$$H = 365 \text{ mm}$$

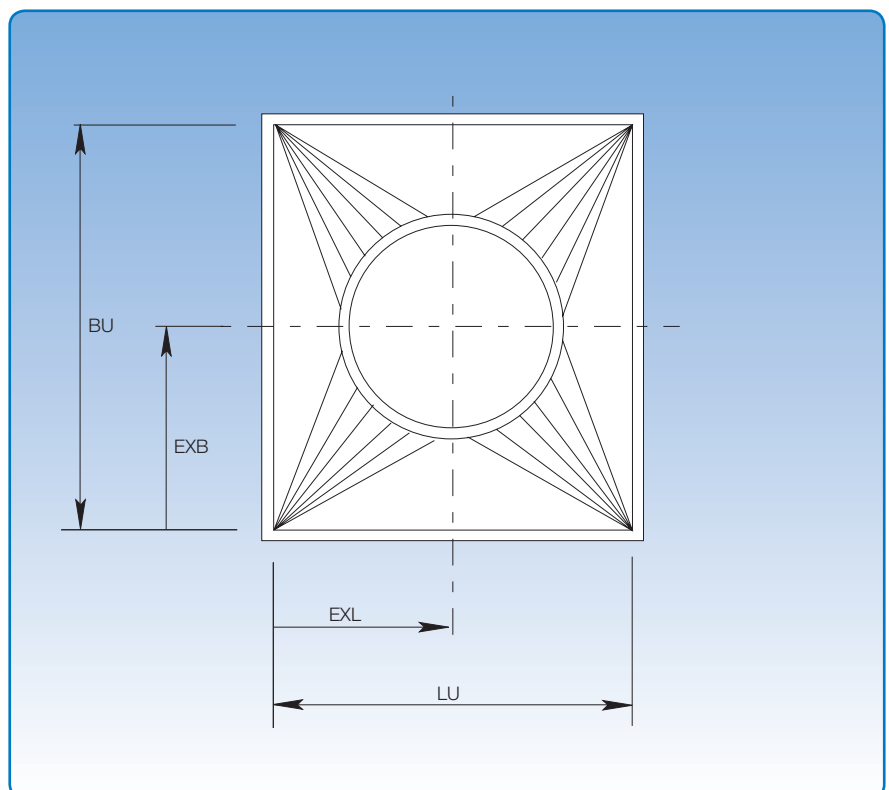

Ducts, 2 and 3 mm

Diameter for 2 mm: $\phi 80$ - $\phi 1250$ mm.

2 and 3 mm ducts $D \leq 600$ mm supplied as standard for pull rings [f.b]. Ducts with $D = \phi 630$ mm - $\phi 1250$ mm supplied with flanges [m.fl].

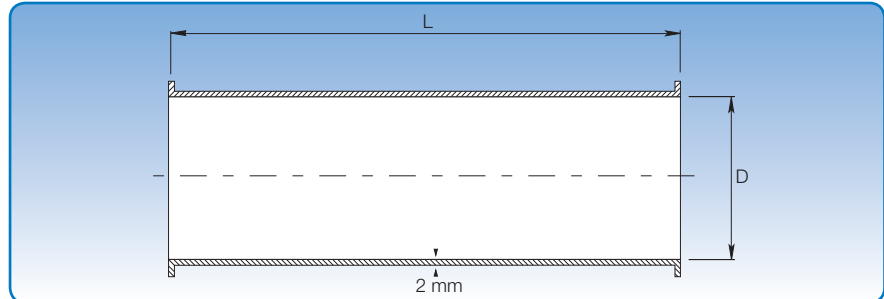

Dimensional specifications are given in the table below.

Dimensions						
D mm	L = 0.5 m		L = 1.0 m		L = 2.0 m	
	Item no.	kg	Item no.	kg	Item no.	kg
80	1040131	2,00	1040141	4,00	1040151	8,00
100	1041131	2,50	1041141	5,00	1041151	10,00
120	1042131	3,10	1042141	6,20	1042151	12,40
125	1043131	3,20	1043141	6,40	1043151	12,80
140	1044131	3,50	1044141	7,00	1044151	14,20
150	1045131	3,80	1045141	7,60	1045151	15,20
160	1046131	4,10	1046141	8,20	1046151	16,40
180	1047131	4,60	1047141	9,10	1047151	18,20
200	1048131	5,10	1048141	10,20	1048151	20,40
225	1049131	5,80	1049141	11,30	1049151	22,70
250	1050131	6,30	1050141	12,60	1050151	25,20
300	1051131	7,60	1051141	15,20	1051151	30,40
315	1052131	7,70	1052141	15,50	1052151	31,00
350	1053131	8,90	1053141	16,80	1053151	33,80
400	1054131	10,10	1054141	20,20	1054151	40,40
450	1055131	11,40	1055141	22,80	1055151	45,60
500	1056131	12,60	1056141	25,20	1056151	50,40
550	1057131	13,90	1057141	27,80	1057151	55,60
600	1058131	15,20	1058141	30,40	1058151	60,80
630	1059135	22,30	1059145	38,20	1059155	70,00
650	1060135	23,00	1060145	39,40	1060155	72,00
700	1061135	24,70	1061145	42,30	1061155	77,50
750	1062135	29,00	1062145	48,00	1062155	85,80
800	1063135	31,00	1063145	52,20	1063155	91,70
850	1064135	32,90	1064145	54,40	1064155	97,00
900	1065135	34,80	1065145	57,40	1065155	102,70
950	1066135	36,80	1066145	60,80	1066155	108,80
1000	1067135	38,60	1067145	63,80	1067155	114,20
1100	1068135	42,50	1068145	71,10	1068155	126,50
1250	1069135	45,20	1069145	76,70	1069155	129,70

Item numbers designated with $D \leq 600$ mm are for ducts assembled with pull rings [f.b].

Item numbers designated with $D \geq 630$ mm are for ducts with flanges [m.fl].

2 and 3 mm ducts are also available for other assembly methods. See p. 7 for assembly methods.

Ducts, 2 and 3 mm

Diameter for 3 mm: $\phi 150 - \phi 1250$ mm.

2 and 3 mm ducts $D \leq 600$ mm supplied as standard for pull rings [f.b]. Ducts with $D = \phi 630$ mm - $\phi 1250$ mm supplied with flanges [m.fl].

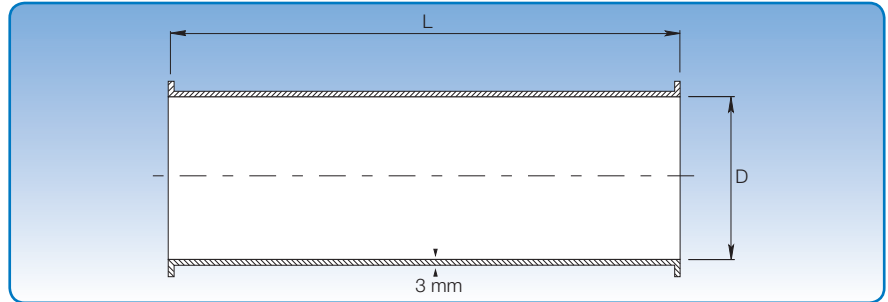

Dimensional specifications are given in the table below.

Dimensions						
D mm	L = 0.5 m		L = 1.0 m		L = 2.0 m	
	Item no.	kg	Item no.	kg	Item no.	kg
150	1045161	5,70	1045171	11,40	1045181	22,80
160	1046161	6,10	1046171	12,20	1046181	24,40
180	1047161	6,80	1047171	13,60	1047181	27,20
200	1048161	7,60	1048171	15,20	1048181	30,40
225	1049161	8,60	1049171	17,10	1049181	34,20
250	1050161	9,60	1050171	19,00	1050181	38,00
300	1051161	11,40	1051171	22,80	1051181	45,60
315	1052161	11,70	1052171	23,30	1052181	46,60
350	1053161	13,30	1053171	26,60	1053181	53,20
400	1054161	15,20	1054171	30,40	1054181	60,80
450	1055161	17,10	1055171	34,20	1055181	68,40
500	1056161	19,00	1056171	38,00	1056181	76,00
550	1057161	20,90	1057171	41,80	1057181	83,60
600	1058161	22,70	1058171	45,40	1058181	90,80
630	1059165	35,20	1059175	54,00	1059185	101,60
650	1060165	31,20	1060175	55,80	1060185	105,00
700	1061165	33,50	1061175	59,90	1061185	112,70
750	1062165	36,00	1062175	66,80	1062185	123,40
800	1063165	41,00	1063175	71,20	1063185	131,60
850	1064165	43,50	1064175	76,70	1064185	139,90
900	1065165	46,10	1065175	80,00	1065185	148,10
950	1066165	48,70	1066175	84,60	1066185	156,40
1000	1067165	52,20	1067175	89,00	1067185	168,60
1100	1068165	56,30	1068175	98,00	1068185	181,00
1250	1069165	61,00	1069175	108,20	1069185	202,70

Item numbers designated with $D \leq 600$ mm are for ducts assembled with pull rings [f.b].

Item numbers designated with $D \geq 630$ mm are for ducts with flanges [m.fl].

2 and 3 mm ducts are also available for other assembly methods. See p. 7 for assembly methods.

Telescopic ducts, 2 mm

Diameter: $\varnothing 100 - \varnothing 600$ mm.

Welded telescopic ducts are made of 2.00 mm sheet metal (s), and supplied with rapid lock pull rings with rubber gasket.

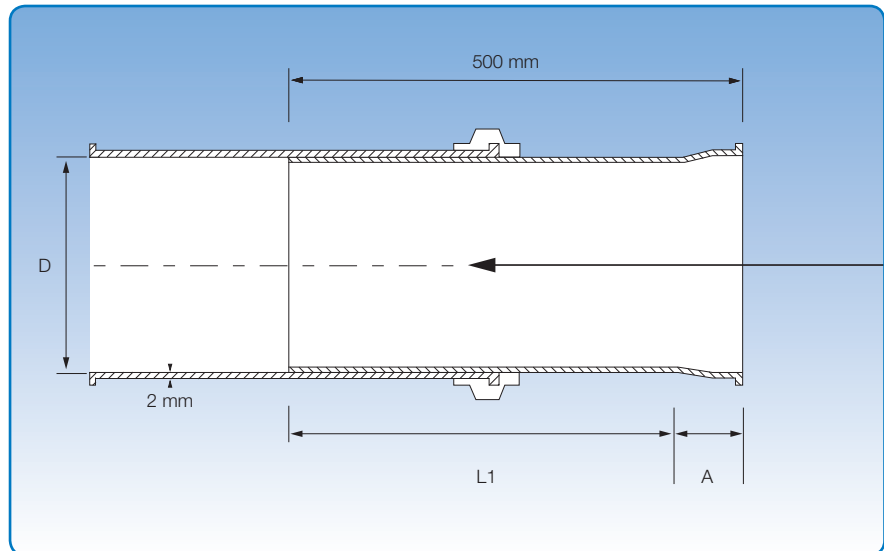

Dimensional specifications are given in the table below.

Item no.	Dimensions			Weight kg
	A mm	L1 mm	D mm	
1069191	55	445	100	2,70
1069201	55	445	120	3,10
1069211	55	445	125	3,40
1069221	65	435	140	3,70
1069231	65	435	150	3,90
1069241	65	435	160	4,20
1069251	65	435	180	4,90
1069261	65	435	200	5,20
1069271	65	435	225	5,80
1069281	65	435	250	6,50
1069291	65	435	275	6,70
1069301	65	435	300	7,80
1069311	65	435	315	8,10
1069321	65	435	350	9,00
1069331	65	435	400	10,10
1069341	65	435	450	11,70
1069351	70	435	500	12,30
1069361	70	456	550	14,60
1069371	70	435	600	15,90

The item numbers stated are for primed telescopic ducts assembled using pull rings [f.b].

Telescopic ducts are also available for other assembly methods. See p. 7 for assembly methods.

Ducts with direct flange, 2 and 3 mm

Diameter: $\phi 300$ - $\phi 1000$ mm.

Ducts with direct flanges are welded and made of 2.00 and 3.00 mm sheet metal (s).

Ducts are supplied with direct flanges [d.fl] in same material as ducts.

Direct flanges can be fitted along with JKF's standard range of loose and welded flanges.

Item numbers stated are for primed ducts.

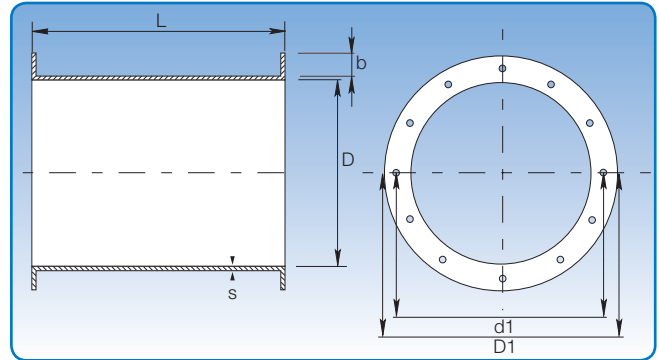

Dimensional specifications are given in the table below.

Dimensions												
D mm	s mm	D1 mm	d1 mm	Weight at L = 0.2 m		Weight at L = 0.5 m		Weight at L = 1.0 m		Weight at L = 2.0 m		Quant. holes
				Item no.	kg	Item no.	kg	Item no.	kg	Item no.	kg	
300	2,00	354	336	1051299	3,20	1051139	7,60	1051149	15,20	1051159	30,40	12
315	2,00	370	351	1052299	3,30	1052139	7,90	1052149	15,80	1052159	31,60	12
350	2,00	415	389	1053299	3,80	1053139	8,90	1053149	17,80	1053159	35,60	12
400	2,00	465	439	1054299	4,30	1054139	10,10	1054149	20,20	1054159	40,40	16
450	2,00	515	489	1055299	4,90	1055139	11,40	1055149	22,80	1055159	45,60	16
500	2,00	565	540	1056299	5,40	1056139	12,60	1056149	25,20	1056159	50,40	16
550	2,00	615	590	1057299	6,00	1057139	13,90	1057149	27,80	1057159	55,60	16
600	2,00	665	640	1058299	6,60	1058139	15,20	1058149	30,40	1058159	60,80	16
630	2,00	695	670	1059299	6,40	1059139	15,90	1059149	31,80	1059159	63,60	24
650	2,00	715	690	1060299	6,60	1060139	16,40	1060149	32,80	1060159	65,60	24
700	2,00	785	750	1061299	7,10	1061139	17,60	1061149	35,20	1061159	70,40	24
750	2,00	835	800	1062299	7,60	1062139	18,90	1062149	37,80	1062159	75,60	24
800	2,00	885	850	1063299	8,10	1063139	20,20	1063149	40,40	1063159	80,80	24
850	2,00	935	900	1064299	8,60	1064139	21,40	1064149	42,80	1064159	85,60	24
900	2,00	985	950	1065299	9,10	1065139	22,70	1065149	45,30	1065159	90,60	24
950	2,00	1035	1000	1066299	9,60	1066139	24,00	1066149	48,00	1066159	96,00	24
1000	2,00	1085	1050	1067299	10,10	1067139	25,20	1067149	50,40	1067159	100,80	24
300	3,00	354	336	1051399	4,80	1051169	11,40	1051179	22,80	1051189	45,60	12
315	3,00	370	351	1052399	5,00	1052169	11,90	1052179	23,70	1052189	47,40	12
350	3,00	415	389	1053399	5,70	1053169	13,30	1053179	26,60	1053189	53,20	12
400	3,00	465	439	1054399	6,50	1054169	15,20	1054179	30,40	1054189	60,80	16
450	3,00	515	489	1055399	7,30	1055169	17,10	1055179	34,20	1055189	68,40	16
500	3,00	565	540	1056399	8,10	1056169	19,00	1056179	38,00	1056189	76,00	16
550	3,00	615	590	1057399	8,40	1057169	20,90	1057179	41,80	1057189	83,60	16
600	3,00	665	640	1058399	9,70	1058169	22,70	1058179	45,40	1058189	90,80	16
630	3,00	695	670	1059399	9,50	1059169	23,80	1059179	47,60	1059189	95,20	24
650	3,00	715	690	1060399	9,70	1060169	24,60	1060179	49,20	1060189	98,40	24
700	3,00	785	750	1061399	10,60	1061169	26,40	1061179	52,80	1061189	105,60	24
750	3,00	835	800	1062399	11,30	1062169	28,30	1062179	56,60	1062189	113,20	24
800	3,00	885	850	1063399	12,10	1063169	30,20	1063179	60,40	1063189	120,80	24
850	3,00	935	900	1064399	12,90	1064169	32,10	1064179	64,20	1064189	128,40	24
900	3,00	985	950	1065399	13,60	1065169	34,00	1065179	68,00	1065189	136,00	24
950	3,00	1035	1000	1066399	14,40	1066169	35,90	1066179	71,80	1066189	143,60	24
1000	3,00	1085	1050	1067399	15,10	1067169	37,80	1067179	75,60	1067189	151,20	24

Duct length/flange width/hole size

D mm	b mm	L = 0.2 m mm	L = 0.5 m mm	L = 1.0 m mm	L = 2.0 mm	Hole size mm
300 - 315	25	200	455	955	1955	9
350 - 650	30	200	445	945	1945	11
700 - 1000	40	200	425	925	1925	11

Welding ends, 2 and 3 mm

Diameter: $\varnothing 80$ - $\varnothing 600$ mm.

Welding ends are made of 2.00 and 3.00 mm sheet metal (s) and supplied untreated.

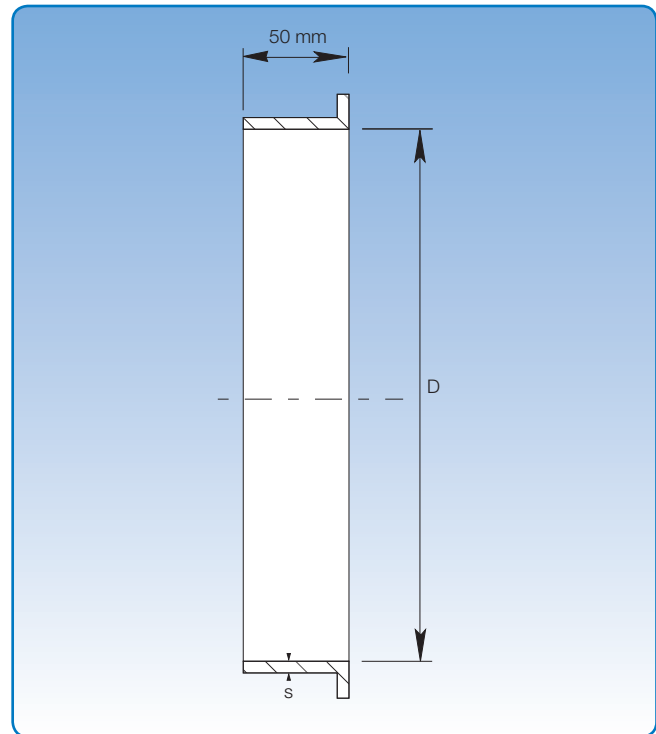

Dimensional specifications are given in the table below.

Dimensions							
D mm	Item no.	s = 2 mm	Weight kg	Item no.	s = 3 mm	Weight kg	
80	1010700		0,22				
100	1011700		0,27				
120	1012700		0,33				
125	1013700		0,34				
140	1014700		0,38				
150	1015700		0,41	1015800		0,62	
160	1016700		0,44	1016800		0,66	
180	1017700		0,49	1017800		0,74	
200	1018700		0,55	1018800		0,82	
225	1019700		0,61	1019800		0,92	
250	1020700		0,68	1020800		1,02	
275	1020710		0,75	1021810		1,12	
300	1021700		0,82	1021800		1,23	
315	1022700		0,86	1022800		1,29	
350	1023700		0,95	1023800		1,43	
400	1024700		1,09	1024800		1,63	
450	1025700		1,27	1025800		1,89	
500	1026700		1,36	1026800		2,04	
550	1027700		1,50	1027800		2,24	
600	1028700		1,63	1028800		2,45	

The item numbers stated are for welding ends assembled using pull rings [f.b].

Welding ends are also available for other assembly methods. See p. 7 for assembly methods.

Pressed bends, 2 and 3 mm

Diameter for 2 mm: $\phi 100 - \phi 400$ mm.

Diameter for 3 mm: $\phi 150 - \phi 200$ mm.

Pressed bends are made of 2.00 and 3.00 mm sheet metal (s).

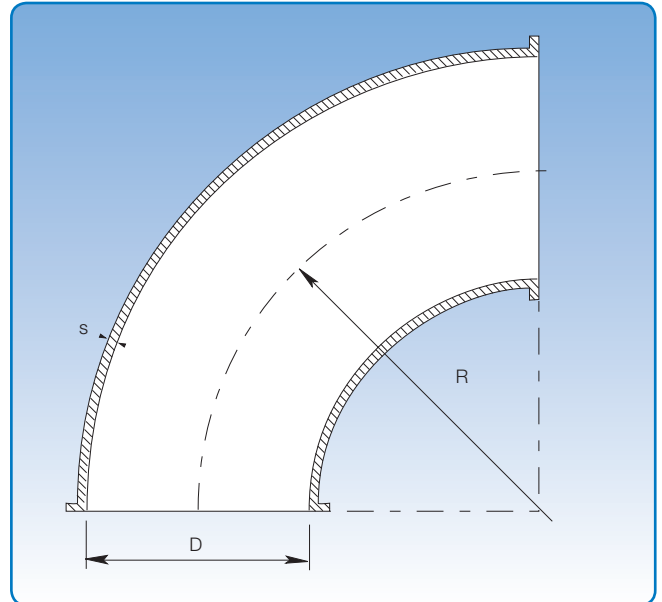

Dimensional specifications are given in the table below.
 $R = 1.5 \times D$ for all dimensions.

When replacing the galvanized bend with 2 – 3.00 mm bend, there may be tolerance differences of ± 20 mm.

Dimensions											
D mm	s mm	90°		60°		45°		30°		15°	
		Item no.	kg	Item no.	kg	Item no.	kg	Item no.	kg	Item no.	kg
100	2,00	1141292	1,20	1141262	0,90	1141242	0,60	1141232	0,40	1141212	0,20
120	2,00	1142292	1,80	1142262	1,20	1142242	0,90	1142232	0,60	1142212	0,30
125	2,00	1143292	2,00	1143262	1,30	1143242	1,00	1143232	0,70	1143212	0,40
150	2,00	1145292	2,90	1145262	2,00	1145242	1,40	1145232	1,00	1145212	0,50
160	2,00	1146292	3,20	1146262	2,20	1146242	1,60	1146232	1,10	1146212	0,70
180	2,00	1147292	3,80	1147262	2,70	1147242	1,90	1147232	1,40	1147212	0,70
200	2,00	1148292	5,00	1148262	3,40	1148242	2,50	1148232	1,70	1148212	0,70
250	2,00	1150292	8,90	1150262	5,90	1150242	4,40	1150232	2,90	1150212	1,40
300	2,00	1151292	12,90	1151262	7,60	1151242	6,40	1151232	4,30	1151212	1,90
350	2,00	1153292	17,80	1153262	12,00	1153242	9,30	1153232	5,20	1153212	3,20
400	2,00	1154292	23,50	1154262	15,70	1154242	11,80	1154232	7,50	1154212	4,10
150	3,00	1145392	4,30	1145362	3,00	1145342	2,20	1145332	1,50	1145312	0,80
160	3,00	1146392	4,80	1146362	3,20	1146342	2,40	1146332	1,60	1146312	1,00
180	3,00	1147392	6,20	1147362	4,10	1147342	3,10	1147332	2,10	1147312	1,10
200	3,00	1148392	7,50	1148362	5,10	1148342	3,70	1148332	2,50	1148312	1,30

The item numbers stated are for primed pressed bends assembled using pull rings [f.b].

Pressed bends are also available for other assembly methods. See p. 7 for assembly methods.

Segment bends, 2 and 3 mm

Diameter for 2 mm: $\phi 140 - \phi 1000$ mm.

Diameter for 3 mm: $\phi 225 - \phi 1000$ mm.

Segment bends are available in other radii and dimensions to order.

2 and 3 mm segment bends are supplied as standard for pull rings [f.b].

Segment bends with $D = \phi 630$ mm - $\phi 1000$ mm supplied with flange [m.fl].

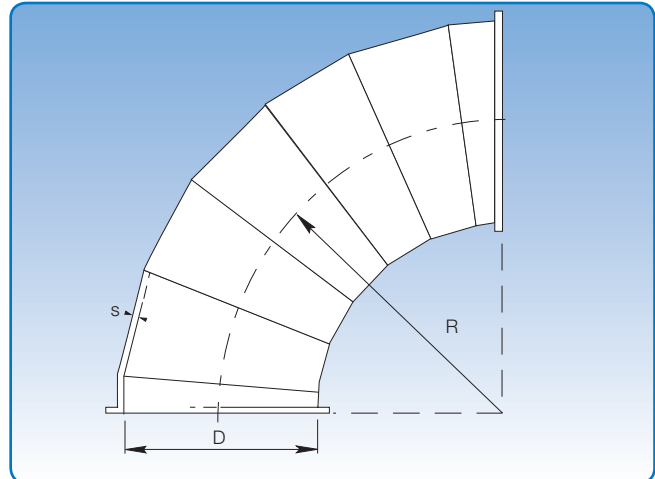

Dimensional specifications are given in the table below.
 $R = 1.5 \times D$ for all dimensions.

Dimensions											
D mm	s mm	90°		60°		45°		30°		15°	
		Item no.	kg	Item no.	kg	Item no.	kg	Item no.	kg	Item no.	kg
140	2,00	1144292	2,90	1144262	2,00	1144242	1,40	1144232	1,00	1144212	0,50
225	2,00	1149292	7,60	1149262	5,20	1149242	3,80	1149232	2,60	1149212	1,40
275	2,00	11588929	9,60	11588629	7,20	11588429	4,80	1152232	3,60	11588129	1,80
315	2,00	1152292	13,30	1152262	8,60	1152242	6,50	11588329	4,40	1152212	2,20
450	2,00	1155892	24,20	1155862	16,20	1155842	12,10	1155832	8,10	1155812	4,00
500	2,00	1156892	29,90	1156862	20,00	1156842	15,00	1156832	10,00	1156812	5,00
550	2,00	1157892	36,20	1157862	24,20	1157842	18,10	1157832	12,10	1157812	6,00
600	2,00	1158892	43,10	1158862	28,80	1158842	21,60	1158832	14,40	1158812	7,20
630	2,00	1159895	53,78	1159865	38,08	1159845	30,18	1159835	22,18	1159815	14,28
650	2,00	1160895	57,17	1160865	40,37	1160845	31,87	1160835	23,47	1160815	14,97
700	2,00	1161895	65,85	1161865	46,25	1161845	36,45	1161835	26,65	1161815	16,85
750	2,00	1162895	77,67	1162865	55,17	1162845	43,97	1162835	32,67	1162815	21,20
800	2,00	1163895	87,61	1163865	62,01	1163845	49,21	1163835	36,41	1163815	23,61
850	2,00	1164895	98,25	1164865	69,25	1164845	54,85	1164835	40,35	1164815	25,95
900	2,00	1165895	109,40	1165865	77,00	1165845	60,80	1165835	44,50	1165815	28,30
950	2,00	1166895	121,14	1166865	85,04	1166845	66,94	1166835	48,84	1166815	30,84
1000	2,00	1167895	133,58	1167865	93,48	1167845	73,48	1167835	53,48	1167815	33,38
225	3,00	1149392	11,10	1149362	7,40	1149342	5,60	1149332	3,70	1149312	1,90
250	3,00	1150392	11,10	1150362	7,40	1150342	5,60	1150332	3,70	1150312	1,90
275	3,00	11589929	14,40	11589629	10,80	11589429	7,20	11589329	5,40	11589129	2,70
300	3,00	1151392	16,10	1151362	10,70	1151342	8,00	1151332	5,40	1151312	2,70
315	3,00	1152392	19,65	1152362	12,90	1152342	9,75	1152332	6,60	1152312	3,30
350	3,00	1153392	22,00	1153362	14,60	1153342	11,00	1153332	7,30	1153312	3,70
400	3,00	1154392	28,60	1154362	19,10	1154342	14,30	1154332	9,50	1154312	4,80
450	3,00	1155992	36,40	1155962	24,20	1155942	18,20	1155932	12,10	1155912	6,10
500	3,00	1156992	44,90	1156962	29,90	1156942	22,40	1156932	15,00	1156912	7,50
550	3,00	1157992	54,40	1157962	36,20	1157942	27,20	1157932	18,10	1157912	9,10
600	3,00	1158992	64,70	1158962	43,20	1158942	32,40	1158932	21,60	1158912	10,80
630	3,00	1159995	77,48	1159965	53,78	1159945	41,98	1159935	30,08	1159915	18,28
650	3,00	1160995	82,57	1160965	57,17	1160945	44,57	1160935	31,87	1160915	19,27
700	3,00	1161995	95,25	1161965	65,85	1161945	51,15	1161935	36,45	1161915	21,75
750	3,00	1162995	111,47	1162965	77,67	1162945	60,77	1162935	43,97	1162915	27,07
800	3,00	1163995	126,01	1163965	87,61	1163945	68,41	1163935	49,21	1163915	30,01
850	3,00	1164995	141,35	1164965	98,05	1164945	76,55	1164935	54,85	1164915	33,15
900	3,00	1165995	158,10	1165965	109,40	1165945	85,10	1165935	60,80	1165915	36,40
950	3,00	1166995	175,34	1166965	121,14	1166945	94,04	1166935	66,94	1166915	39,84
1000	3,00	1167995	193,68	1167965	133,58	1167945	103,58	1167935	73,48	1167915	43,48

Item numbers designated with $D \leq 600$ mm are for segment bends assembled with pull rings [f.lyn]. Item numbers designated with $D \geq 630$ mm are for ducts with flange [m.fl]. 2 and 3 mm ducts are also available for other assembly methods. See p. 7 for assembly methods.

30° straight branch pieces, 2 and 3 mm

Diameter for 2 mm: $\phi 100 - \phi 1000$ mm.

Diameter for 3 mm: $\phi 150 - \phi 1000$ mm.

Straight branch pieces are welded and made of 2.00 and 3.00 mm sheet metal (s). Straight branch pieces with $A = C \leq 600$ mm are supplied for assembly with pull rings [f.b] and for $A = C \geq 630$ mm with flanges [m.fl].

When assembled with loose flanges, [f.b.m.fl], and flanges [m.fl] L1 is extended by 2×50 mm.

State A-, B- and C dimensions when ordering. Options are limited by $A = C$, and $A \geq B$.

The branch determines the length of L1. Branch pieces are always straight with the branch centrally located.

L1, L2 and L3 can be calculated using the stated formulas.

For double branch pieces, the highest value of dim. B determines L1 on the common branch. L2 and L3 can then be calculated for both branches. Normally, the branches are opposite each other.

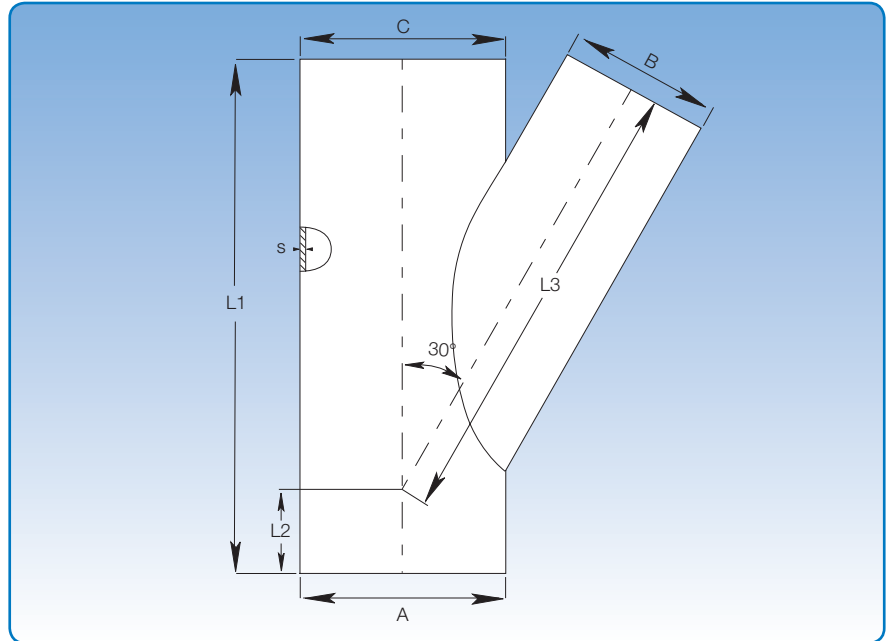

Calculating L2 and L3:

L1 = see table

$$L2 = \frac{L1}{2} - \left(\frac{A}{2 \times \tan 30^\circ} \right)$$

$$L3 = \frac{L1 - L2}{\cos 30^\circ} - \left(\frac{B}{2} \times \tan 30^\circ \right)$$

Example:

A = B = C = 450

L1 = 1250 mm

$$L2 = \frac{1250}{2} - \left(\frac{450}{\tan 30^\circ} \right) = 625 - 389,71$$

L2 = 235,29 ~ 235 mm

$$L3 = \frac{1250 - 235}{\cos 30^\circ} - \left(\frac{450}{2} \times \tan 30^\circ \right) = 1172,06 - 129,92$$

L3 = 1042,14 ~ 1042 mm

Dimensions				
A = C mm	B mm	L1 mm	L2 mm	L3 mm
Select (100 - 1000)	80	350	Calculate	Calculate
	100	350		
	120	350		
	125	400		
	140	450		
	150	450		
	160	450		
	180	550		
	200	550		
	225	600		
	250	750		
	275	750		
	300	750		
	315	850		
	350	950		
	400	1050		
	450	1250		
	500	1250		
	550	1450		
	600	1450		
650	1650			
700	1650			
750	1850			
800	1850			
850	2050			
900	2050			

30° conical branch pieces, 2 and 3 mm

Diameter A for 2 mm: $\phi 120 - \phi 1000$ mm.
 Diameter A for 3 mm: $\phi 150 - \phi 1000$ mm.

Conical branch pieces are welded and made of 2.00 and 3.00 mm sheet metal (s). Conical branch pieces with $A \leq 600$ mm are supplied for assembly with pull rings [f.b] and for $A \geq 630$ mm with flanges [m.fl].

L1 is extended by a 50 mm welding end at dimension C if the branch piece is supplied with flanges [m.fl], loose flanges [f.b.m.fl] or rapid lock pull rings [f.lyn].

State branch piece A-, B- and C dimensions when ordering. A, B and C can be combined to order; although branch B determines length L1 as stated in the table.

Maximum difference between diameter A and C is 100 mm. For B applies:
 $B < (A+C)/2$.

The highest value of dimension B determines L1 on the common stem for double branch pieces. L2 and L3 can then be calculated for both branches. Normally, the branches are opposite each other.

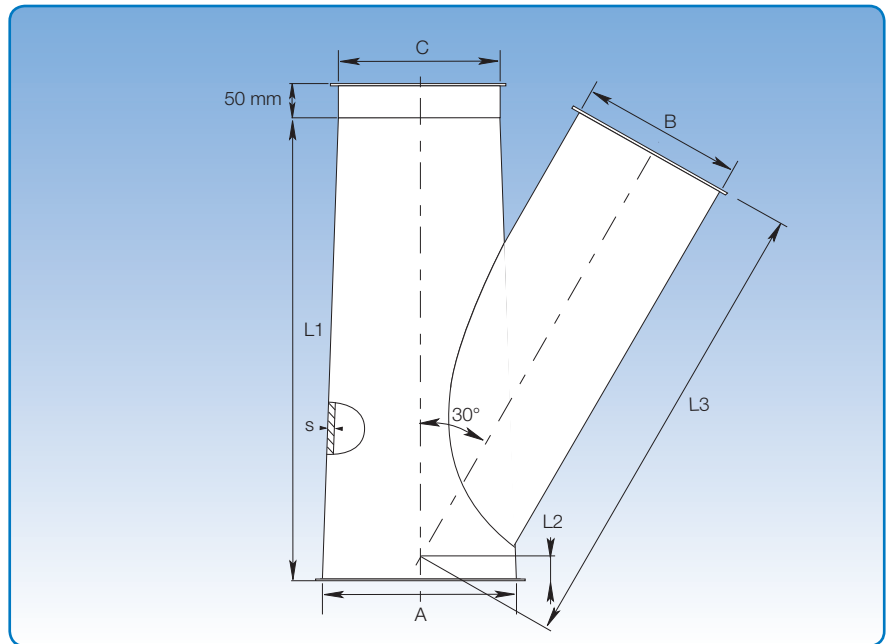

Calculating L2 and L3:

L1 = See table

$$L2 = \left(\frac{L1}{2} \right) - \left(\frac{A + C}{4 \times \tan 30^\circ} \right)$$

$$L3 = \left(\frac{L1 - L2}{\cos 30^\circ} \right) - \left(\frac{B}{2} \times \tan 30^\circ \right)$$

Example:

A = 500, B = 300, C = 400

L1 = 750 mm

$$L2 = \frac{750}{2} - \frac{500 + 400}{4 \times \tan 30^\circ} = 375 - 389,71$$

L2 = - 14,71 ~ - 15 mm

$$L3 = \frac{750 - 15}{\cos 30^\circ} - \left(\frac{300}{2} \times \tan 30^\circ \right) = 848,70 - 86,61$$

L3 = 762,1 ~ 762 mm

Dimensions					
A mm	B mm	C mm	L1 mm	L2 mm	L3 mm
Select (100 - 1000)	80	Select (100 - 1000)	350	Calculate	Calculate
	100		350		
	120		350		
	125		400		
	140		450		
	150		450		
	160		450		
	180		550		
	200		550		
	225		600		
	250		750		
	275		750		
	300		750		
	315		850		
	350		950		
	400		1050		
	450		1250		
	500		1250		
	550		1250		
	600		1450		
650	1650				
700	1650				
750	1850				
800	1850				
850	2050				
900	2050				

45° conical branch pieces, 2 and 3 mm

Diameter A for 2 mm: ø120 - ø1000 mm.

Diameter A for 3 mm: ø150 - ø1000 mm.

Conical branch pieces are welded and made of 2.00 and 3.00 mm sheet metal (s). Conical branch pieces with $A \leq 600$ mm are supplied for assembly with pull rings [f.b] and for $A \geq 630$ mm with flanges [m.fl].

L1 is extended by a 50 mm welding end at dimension C if the branch piece is supplied with flanges [m.fl], loose flanges [f.b.m.fl] or rapid lock pull rings [f.lyn].

State branch piece A-, B- and C dimensions when ordering. A, B and C can be combined to order; although branch B determines length L1 as stated in the table.

Maximum difference between diameter A and C is 100 mm. For B applies:

$$B < (A+C)/2.$$

The highest value of dimension B determines L1 on the common stem for double branch pieces. L2 and L3 can then be calculated for both branches. Normally, the branches are opposite each other.

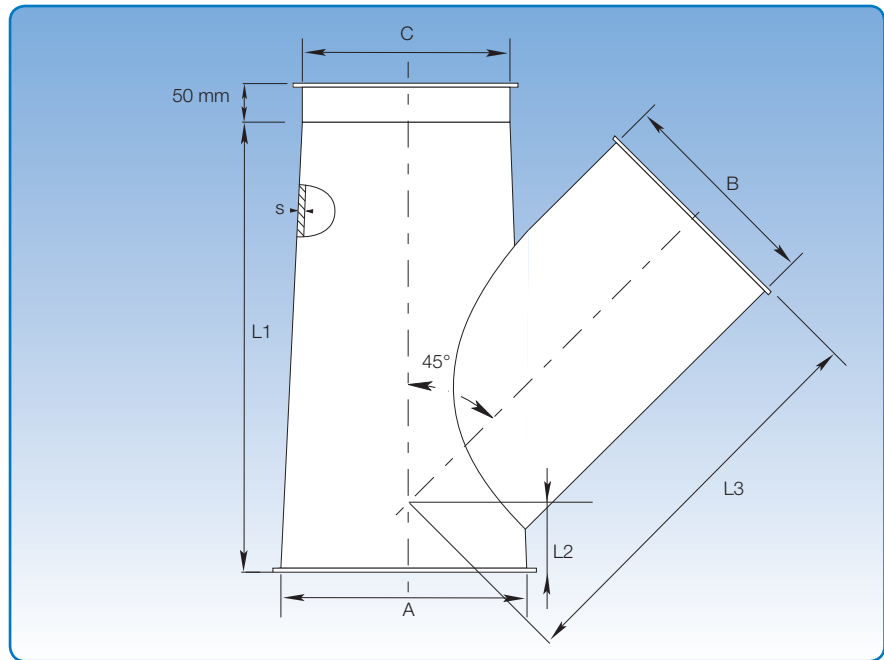

Calculating L2 and L3:

L1 = See table

$$L2 = \left(\frac{L1}{2} \right) - \left(\frac{A+C}{4 \times \text{tg } 45^\circ} \right)$$

$$L3 = \left(\frac{L1-L2}{\cos 45^\circ} \right) - \left(\frac{B}{2} \times \text{tg } 45^\circ \right)$$

Example:

A = 650, B = 315, C = 600

L1 = 600 mm

$$L2 = \frac{600}{2} - \frac{650 + 600}{4 \times \text{tg } 45^\circ} = 300 - 312,5$$

L2 = - 12,5 ~ - 13 mm

$$L3 = \frac{600 + 13}{\cos 45^\circ} - \left(\frac{315}{2} \times \text{tg } 45^\circ \right) = 866,92 - 157,5$$

L3 = 709,42 ~ 709 mm

Dimensions					
A mm	B mm	C mm	L1 mm	L2 mm	L3 mm
Select (100 - 1000)	80	Select (100 - 1000)	300	Calculate	Calculate
	100		300		
	120		350		
	125		350		
	140		350		
	150		400		
	160		400		
	180		400		
	200		450		
	225		500		
	250		500		
	275		600		
	300		600		
	315		600		
	350		700		
	400		800		
	450		950		
	500		1050		
	550		1150		
	600		1250		
650	1150				
700	1300				
750	1300				
800	1450				
850	1450				
900	1650				

30° trouser pieces, 2 and 3 mm

Diameter A for 2 mm: $\phi 100 - \phi 1000$ mm.

Diameter A for 3 mm: $\phi 150 - \phi 1000$ mm.

Trouser pieces are welded and made of 2.00 and 3.00 mm sheet metal (s).

Trouser pieces with $A = B = C \leq 600$ mm are supplied for assembly with pull rings [f.b].

Trouser pieces with $A = B = C \geq 630$ mm are supplied for assembly with flanges [m.fl].

Produced as straight trouser pieces when $A=B=C$.

State A, B and C dimensions when ordering.

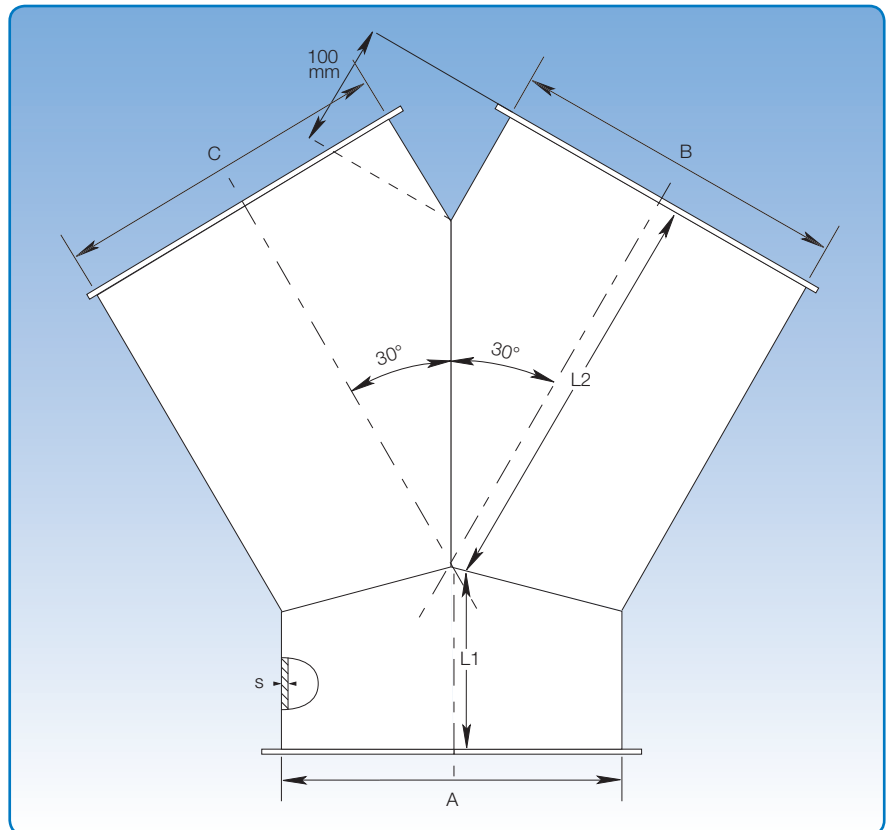

Calculating L1 and L2:

$$L1 = 0,5 \times A$$

$$L2 = \cos 30^\circ \times A + 100$$

Example:

$$A = B = C = 350$$

$$L1 = 0,5 \times 350 = 175$$

$$L1 = 175 \text{ mm}$$

$$L2 = (0,866 \times 350) + 100 = 403,1$$

$$L2 = 403 \text{ mm}$$

90° T-pieces, 2 and 3 mm

Diameter for 2 mm: $\varnothing 80 - \varnothing 1000$ mm.

Diameter for 3 mm: $\varnothing 150 - \varnothing 1000$ mm.

90° T-pieces are welded and made of 2.00 and 3.00 mm sheet metal (s). T-pieces with $A = C \leq 600$ mm are supplied for assembly with pull rings [f.b]. T-pieces with $A = C \geq 630$ mm are supplied with flanges [m.fl].

For dimensions: $A = C \geq B$.

State A, B and C dimensions when ordering.

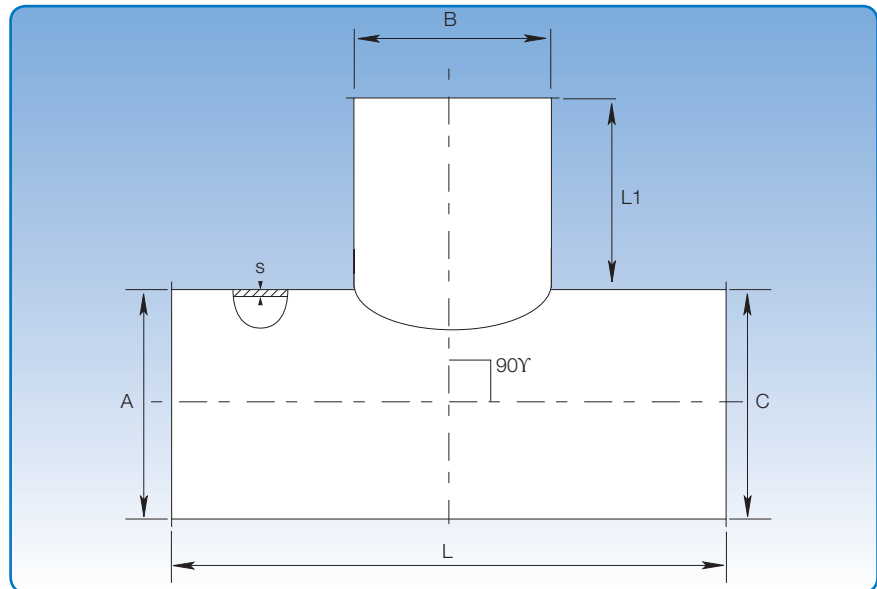

Dimensional specifications are given in the table below.

Dimensions				
B mm	s mm	L mm	L1 mm	
80	2,00	230	75	
100	2,00	250	75	
120	2,00	270	75	
125	2,00	275	75	
140	2,00	290	75	
150	2,00 and 3,00	300	75	
160	2,00 and 3,00	310	75	
180	2,00 and 3,00	330	75	
200	2,00 and 3,00	350	75	
225	2,00 and 3,00	425	100	
250	2,00 and 3,00	450	100	
275	2,00 and 3,00	475	100	
300	2,00 and 3,00	500	100	
315	2,00 and 3,00	515	100	
350	2,00 and 3,00	550	100	
400	2,00 and 3,00	600	100	
450	2,00 and 3,00	750	150	
500	2,00 and 3,00	800	150	
550	2,00 and 3,00	850	150	
600	2,00 and 3,00	900	150	
630	2,00 and 3,00	930	150	
650	2,00 and 3,00	950	150	
700	2,00 and 3,00	1100	200	
750	2,00 and 3,00	1150	200	
800	2,00 and 3,00	1200	200	
850	2,00 and 3,00	1250	200	
900	2,00 and 3,00	1300	200	
950	2,00 and 3,00	1350	200	
1000	2,00 and 3,00	1400	200	

Tapers, 2 and 3 mm

Diameter A for 2 mm: $\phi 100 - \phi 1000$ mm.

Diameter A for 3 mm: $\phi 160 - \phi 1000$ mm.

Tapers are made in standard dimensions as stated in the table.

Other dimensions can be made to order. Tapers with $A \leq 600$ mm are supplied as standard for assembly with pull rings [f.b]. Tapers with $A \geq 630$ mm are supplied as standard with flanges [m.fl]. When ordering standard tapers, state A and B dimensions and assembly method. L will depend on the difference between A and B.

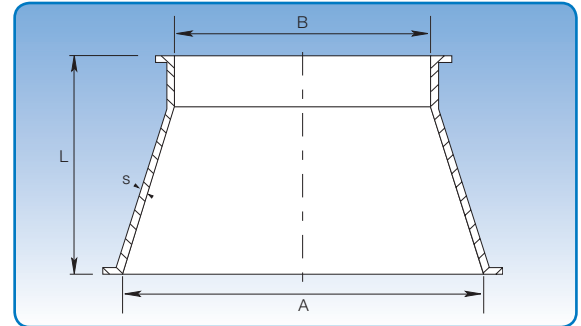

Dimensional specifications for standard tapers are given in the table below.

Dimensions						
Item no.	A mm	B mm	s mm	L mm	Weight kg	
1842417	100	80	2,00	150	0,74	
1842428	120	100	2,00	150	0,89	
1844435	125	100	2,00	150	0,92	
1844437	125	120	2,00	150	0,92	
1844448	140	100	2,00	200	1,38	
1846454	150	100	2,00	200	1,48	
1846455	150	120	2,00	200	1,48	
1846456	150	125	2,00	150	1,11	
1846457	150	140	2,00	150	1,11	
1847464	160	100	2,00	250	1,97	
1847465	160	120	2,00	200	1,58	
1847466	160	125	2,00	200	1,58	
1847467	160	150	2,00	150	1,18	
1847468	160	140	2,00	150	1,18	
1848475	180	100	2,00	300	1,84	
1848476	180	125	2,00	250	1,68	
1848477	180	150	2,00	200	1,57	
1849482	200	100	2,00	300	1,98	
1849483	200	125	2,00	250	1,79	
1849484	200	140	2,00	250	1,88	
1849485	200	150	2,00	200	1,65	
1849486	200	160	2,00	200	1,68	
1849487	200	180	2,00	150	1,36	
1850496	225	180	2,00	150	1,66	
1850497	225	200	2,00	200	2,22	
1851399	250	150	2,00	300	3,70	
1851401	250	160	2,00	300	3,70	
1851403	250	180	2,00	250	3,08	
1851405	250	200	2,00	200	2,47	
1851407	250	225	2,00	150	1,85	
1852110	275	250	2,00	150	2,03	
1852111	275	225	2,00	200	2,71	
1852112	275	200	2,00	250	3,39	
1852415	300	200	2,00	300	4,44	
1852416	300	225	2,00	250	3,70	
1852417	300	250	2,00	200	2,96	
1852418	300	275	2,00	150	2,22	
1853426	315	300	2,00	150	2,33	
1853427	315	275	2,00	200	3,11	
1853428	315	250	2,00	250	3,88	
1854435	350	250	2,00	300	5,18	
1854436	350	275	2,00	200	3,45	
1854437	350	300	2,00	250	4,32	
1855445	400	315	2,00	300	5,92	
1855446	400	350	2,00	300	5,92	
1855447	400	300	2,00	250	4,93	

Tapers, 2 and 3 mm

Dimensions						
Item no.	A mm	B mm	s mm	L mm	Weight kg	
1856458	450	350	2,00	200	4,44	
1857466	500	450	2,00	300	6,66	
1857467	450	400	2,00	200	4,93	
1857468	500	400	2,00	300	7,40	
1858478	550	450	2,00	300	8,14	
1859488	600	500	2,00	300	8,88	
1860498	630	550	2,00	300	14,82	
1861408	650	550	2,00	300	15,17	
1862418	700	600	2,00	300	17,38	
1863428	750	650	2,00	300	19,94	
1864438	800	700	2,00	300	11,84	
1865448	850	750	2,00	300	21,71	
1866458	900	800	2,00	300	23,63	
1867458	950	850	2,00	300	24,97	
1868458	1000	900	2,00	300	26,30	
1846760	160	150	3,00	150	1,78	
1849780	200	150	3,00	200	2,66	
1849781	200	160	3,00	200	2,74	
1849782	200	180	3,00	150	2,16	
1850796	225	180	3,00	200	3,03	
1850797	225	200	3,00	150	2,39	
1851706	250	225	3,00	150	2,66	
1851707	250	200	3,00	200	3,48	
1852210	275	250	3,00	150	3,00	
1852211	275	225	3,00	200	3,11	
1852715	300	200	3,00	300	5,77	
1852717	300	250	3,00	200	4,14	
1852718	300	275	3,00	150	3,22	
1853727	315	275	3,00	200	4,44	
1853728	315	300	3,00	150	3,44	
1854735	350	300	3,00	200	4,88	
1854736	350	315	3,00	200	5,03	
1855748	400	350	3,00	200	5,62	
1856758	450	400	3,00	200	6,36	
1857767	500	400	3,00	300	10,21	
1857768	500	450	3,00	200	7,10	
1858778	550	450	3,00	300	11,32	
1859788	600	500	3,00	300	12,43	
1860798	630	550	3,00	300	18,60	
1861708	650	550	3,00	300	19,09	
1862718	700	600	3,00	300	21,67	
1883728	750	650	3,00	300	24,60	
1864738	800	700	3,00	300	26,00	
1865748	850	750	3,00	300	27,71	
1866758	900	800	3,00	300	29,40	
1867758	950	850	3,00	300	31,11	
1868758	1000	900	3,00	300	32,81	

Specifications for relationship between diameter (A - B) and length (L) for non-standard tapers. Length L will depend on the difference between A and B. Please state A, B and L measurements when ordering.

A - B [mm]	25	50	75	100	125	150	175	200	225	250	275	300
L [mm]	100	150	200	250	300	350	400	450	500	550	600	650

Transition pieces, 2 and 3 mm

Diameter D for 2 mm: $\phi 120 - \phi 1000$ mm.

Diameter D for 3 mm: $\phi 150 - \phi 1000$ mm.

Transition pieces are made of 2.00 and 3.00 mm sheet metal (s).

Transition pieces with $D \leq 600$ mm are supplied as standard for assembly with pull rings [f.b]. Transition pieces with $D \geq 650$ mm are supplied with flanges [m.fl].

State dimensions for BU \times LU and D plus assembly method when ordering (p. 7).

Can be made to order in other dimensions. Also available in asymmetric format.

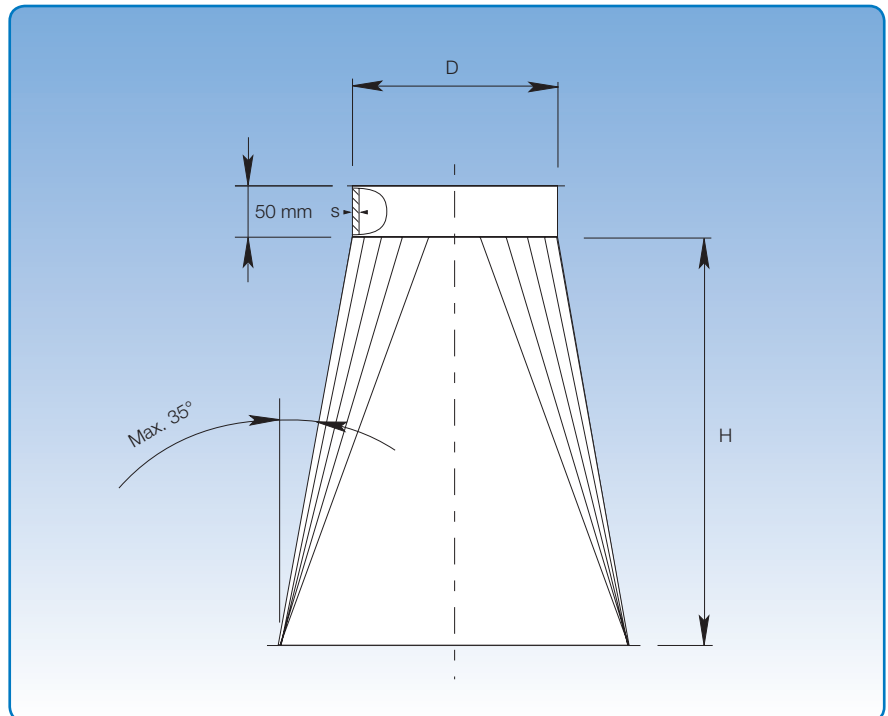

Calculating H:

$$H = 240 + 0,5 \times (\text{max. value of LU} - D)$$

or (BU - D)

Example:

$$D = 350, LU = 400, BU = 600, EXL = 200, EXB = 300$$

$$H = 240 + (0,5 \times 250) = 240 + 125$$

$$H = 365 \text{ mm}$$

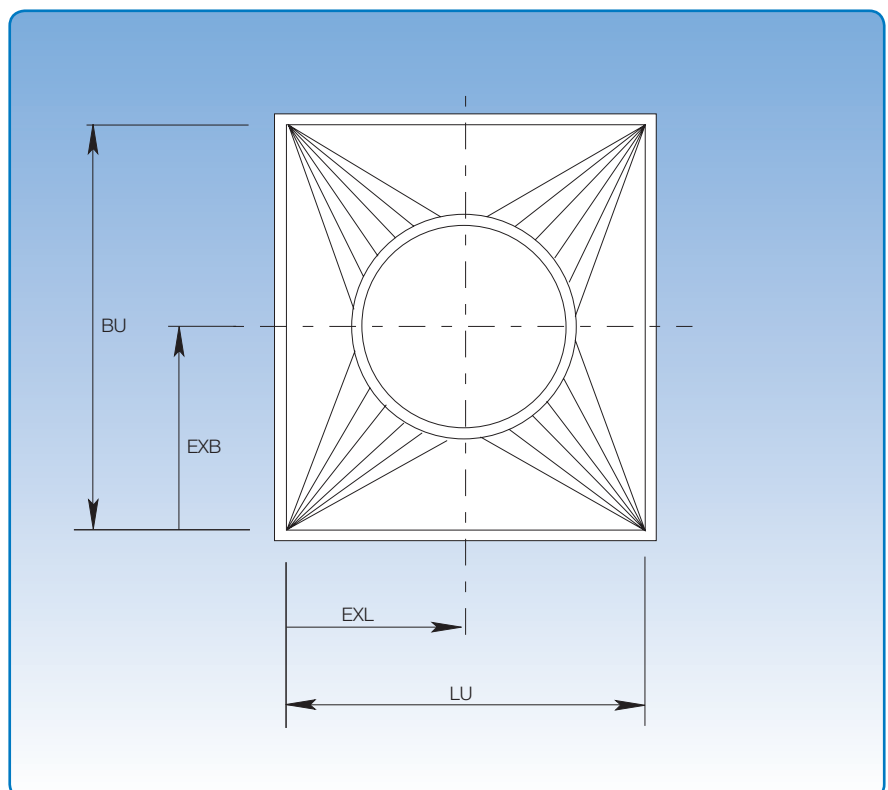

JK-6" duct systems

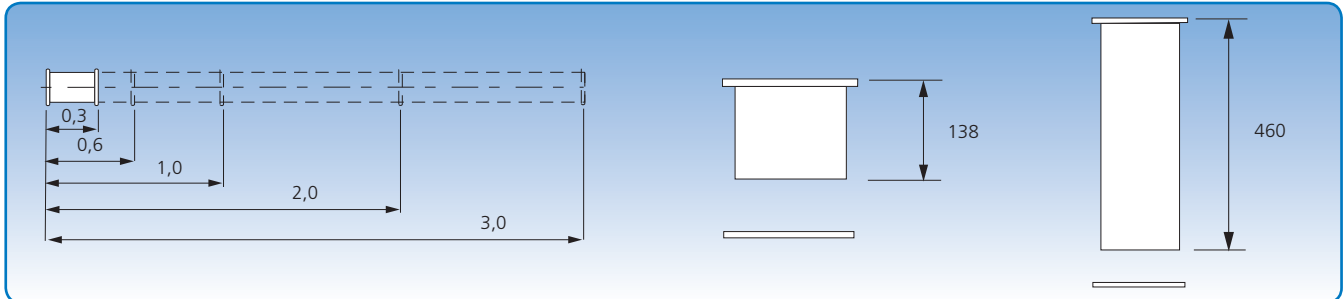

JK-6" duct systems, galvanised

0.1 m telescopic ducts, galvanised

0.5 m telescopic ducts, galvanised

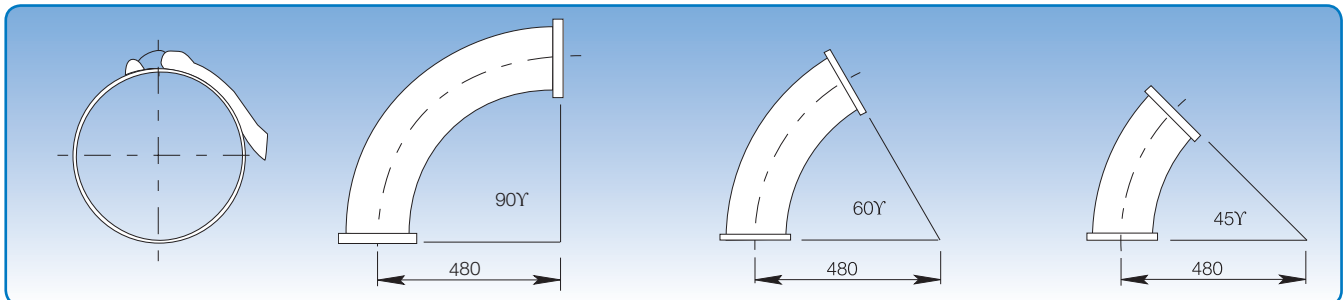

Rapid lock pull rings, galvanised

90° bends, grey

60° bends, grey

45° bends, grey

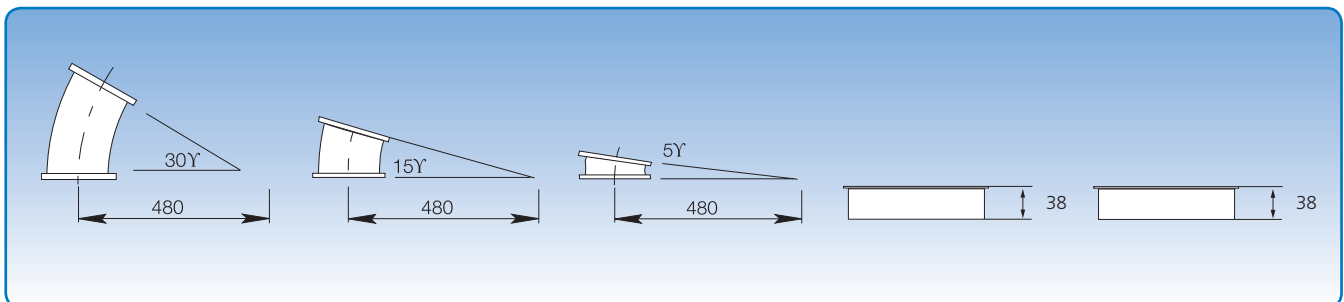

30° bends, grey

15° bends, grey

5° bends, grey

Welding ends, 1.0 mm

Welding ends, 2.0 mm

The JK-6" duct system is specially designed for fast installation and tight, smooth assemblies. Assembly method is rapid lock pull rings.

The special design facilitates high transport capacity and with minimum risk. The rolled ends of the JK-6" system provide strength and minimise the risk of transport damage.

JK-6" duct systems

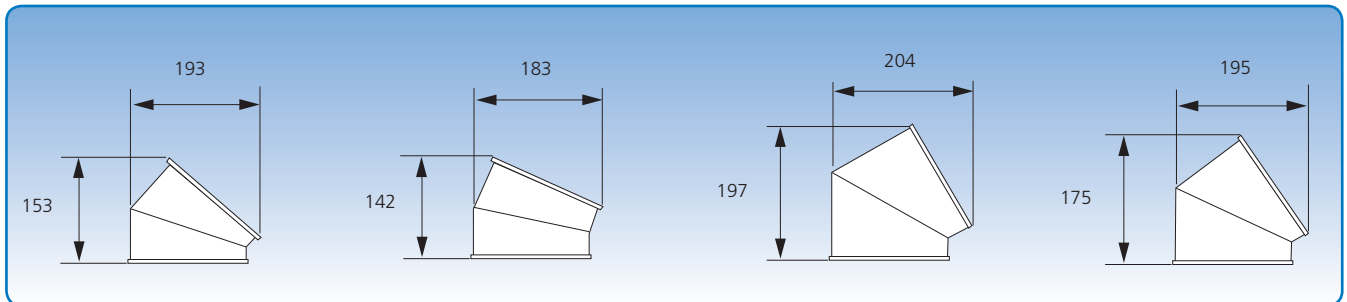

30° segment bends, 1.5 mm, grey

15° segment bends, 1.5 mm, grey

60° segment bends, 1.5 mm, grey

45° segment bends, 1.5 mm, grey

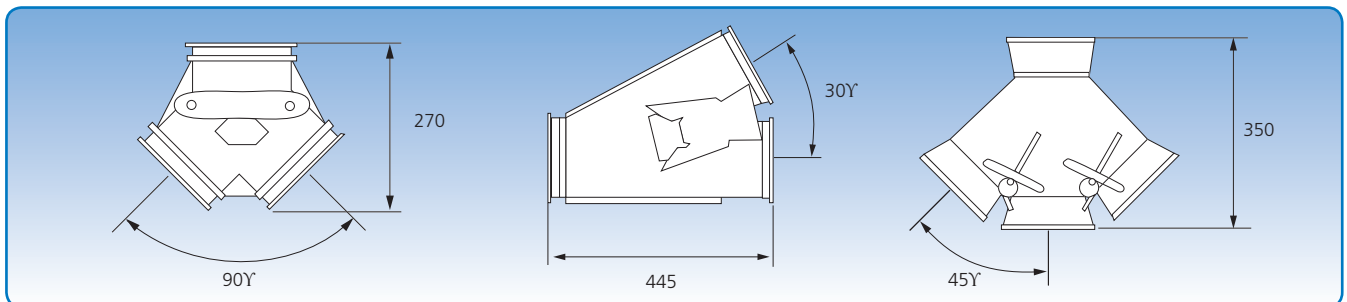

Trouser diverters, 45°, grey

Branch diverters, 30°, grey

Three-way diverters, 45°, grey

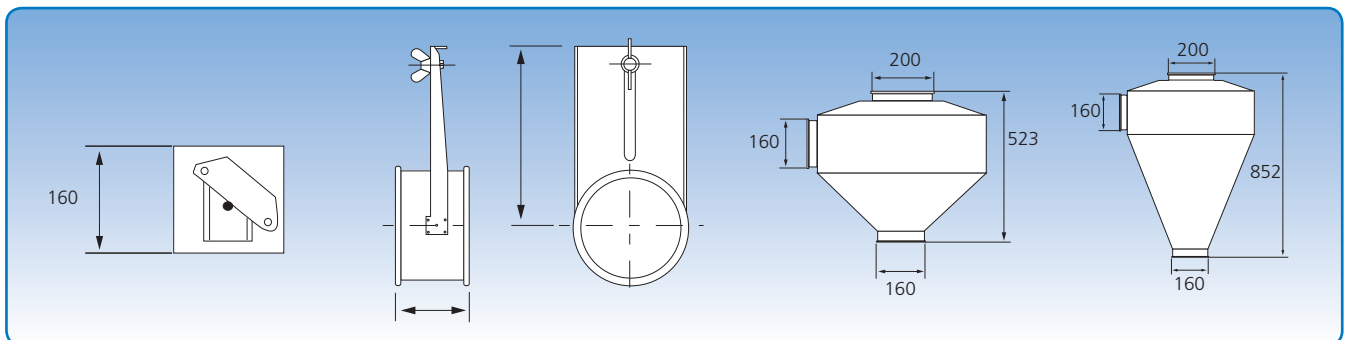

Spring-loaded throttle valves, grey

Bulkheads, grey

Exhaust cyclones, galvanised

Dust cyclones, galvanised

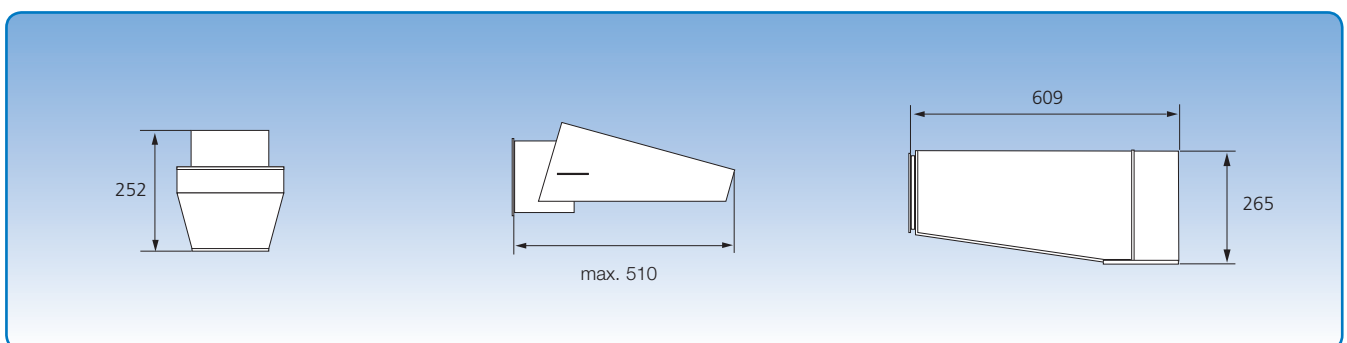

Swing outlets, grey

Outlet nozzles, blue

Exhaust heads, galvanised

Automation for sliding dampers, throttle valves and diverters

The circuit diagrams shown apply to standard systems for sliding dampers, diverters and throttle valves.

These systems are valid for pneumatic connection of max. 6 bar and mains connection of 230 V AC.

Systems with other voltage ratings can be supplied.

Relevant circuit diagrams can be supplied for other voltages.

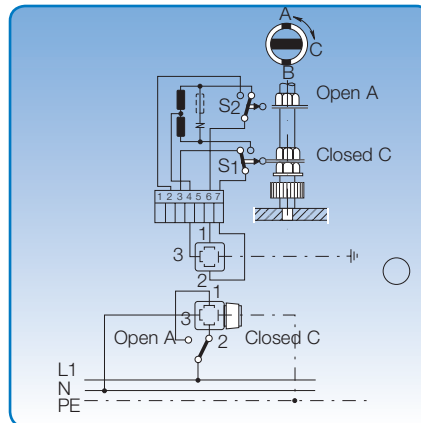

Circuit diagram for electrical motor for diverters, pressed, diameter: ø100 - ø300 mm.

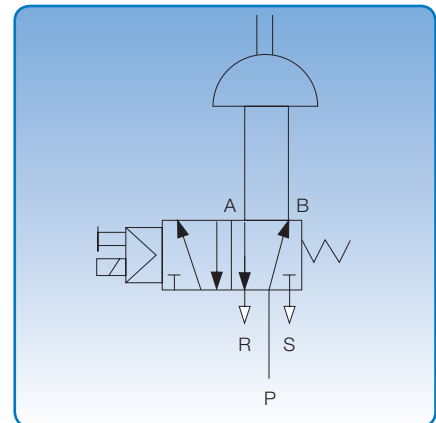

Circuit diagram for pneumatic actuator for diverters, pressed, diameter: ø100 - ø300 mm and throttle valves, diameter: ø80 - ø400 mm.

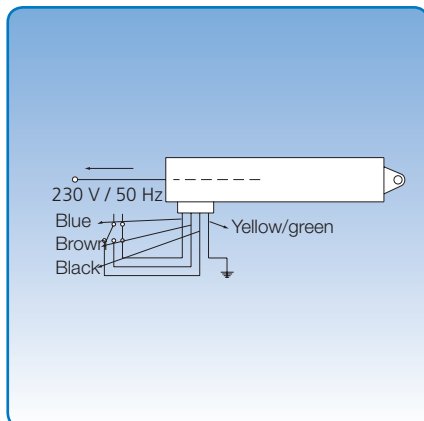

Circuit diagram for electrical cylinder for diverters, welded, diameter: ø80 - ø550 mm and sliding damper standard, diameter: ø80 - ø275 mm.

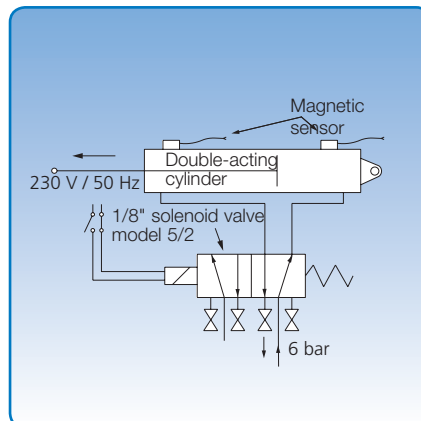

Circuit diagram for pneumatic cylinder for diverters, welded, diameter: ø80 - ø550 mm and sliding damper standard, diameter: ø80 - ø550 mm.

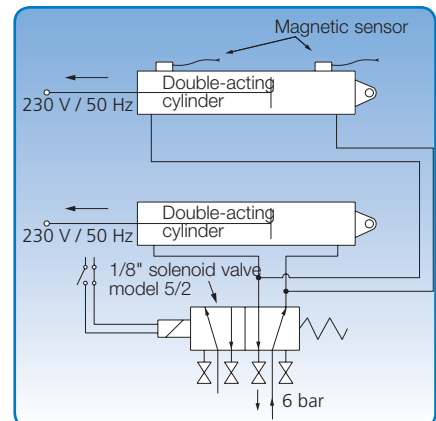

Circuit diagram for 2 pneumatic cylinders for tight sliding dampers, diameter: ø80 - ø550 mm.

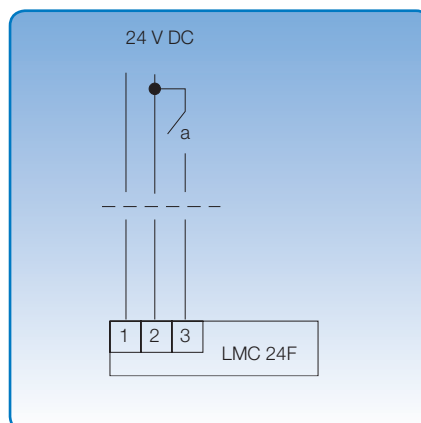

Circuit diagram for 24 V DC electric motor for throttle valves.

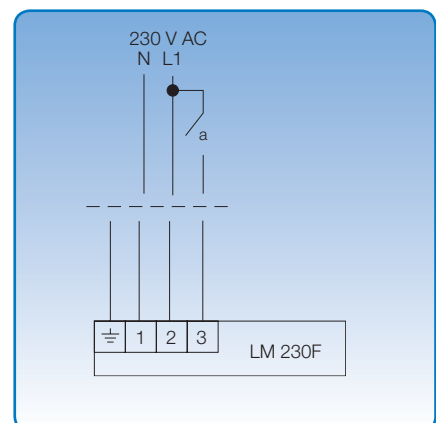

Circuit diagram for 230 V AC electric motor for throttle valves.

Tight sliding dampers, galvanised, manual & pneumatic

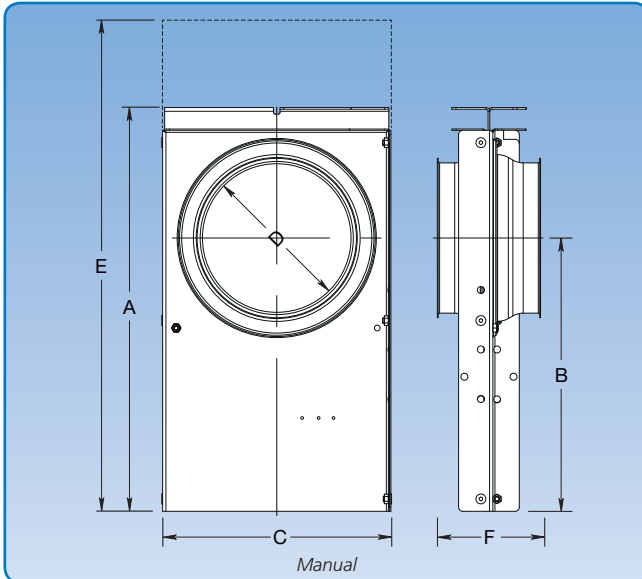

Dimensional specifications are given in the table below.

General

Sliding dampers are made of 1.50 mm, 2.00 mm and 2.50 mm galvanised sheet metal (s). The damper plate slides in the polyether and PEHD gaskets to ensure optimum tightness.

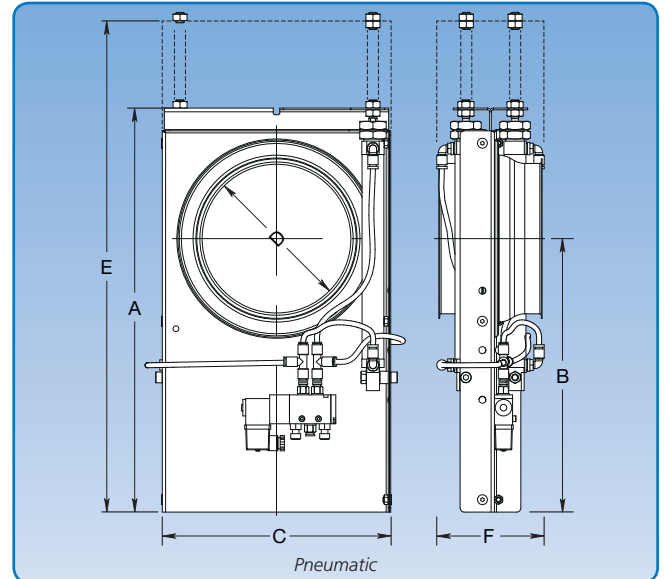

Dimensional specifications are given in the table below.

With pneumatic actuator

The pneumatic damper is for $\varnothing 50$ up to $\varnothing 160$ mm fitted with 1 pneumatic cylinder. From $\varnothing 180$ it is fitted with 2 pneumatic cylinders.

Dimensions												
Item no. (Man.)	Item no. (Pneu./ 24 V DC)	Item no. (Pneu./ 230 V AC)	D mm	A mm	B mm	C mm	E mm	F mm	Material thickness Damper plate (mm)	Material thickness Damper house (mm)	Weight (kg) Manual	Weight (kg) Pneu.
1460001	1461001	1461505	50*	220	130	140	295	145	2,0	1,5	1,7	2,8
1460005	1461005	1461515	63*	220	130	140	295	145	2,0	1,5	1,7	2,8
1460007	1461007	1461525	76*	250	150	160	340	145	2,0	1,5	2,1	3,2
1460010	1461010	1461535	80	250	150	160	340	125	2,0	1,5	2,1	3,1
1460035	1461035	1461545	100	290	180	180	400	125	2,0	1,5	2,6	3,6
1460045	1461045	1461555	108*	340	220	205	475	145	2,0	1,5	3,3	4,7
1460060	1461060	1461565	120	340	220	205	475	125	2,0	1,5	3,3	4,3
1460085	1461085	1461575	125	340	220	205	475	125	2,0	1,5	3,3	4,3
1460110	1461110	1461585	140	390	255	230	550	125	2,0	1,5	4,0	5,1
1460135	1461135	1461595	150	390	255	230	550	125	2,0	1,5	4,0	5,1
1460140	1461140	1461600	152*	390	255	230	560	145	2,0	1,5	4,3	5,4
1460160	1461160	1461605	160	410	270	240	580	125	2,0	1,5	4,3	5,5
1460185	1461185	1461615	180	490	330	280	700	125	2,0	1,5	5,7	7,5
1460210	1461210	1461625	200	490	330	280	700	125	2,0	1,5	5,8	7,5
1460235	1461235	1461635	225	590	405	350	850	165	3,0	2,0	11,7	13,5
1460260	1461260	1461645	250	590	405	375	850	165	3,0	2,0	12,1	14,0
1460275	1461275	1461655	275	650	445	400	975	165	3,0	2,0	14,7	18,7
1460285	1461285	1461665	300	730	505	425	1055	165	3,0	2,0	16,6	20,7
1460310	1461310	1461675	315	730	505	440	1055	165	3,0	2,0	16,9	20,9
1460335	1461335	1461685	350	800	555	475	1160	165	3,0	2,0	19,6	23,9
1460360	1461360	1461695	400	900	630	525	1310	165	3,0	2,0	23,5	28,5
1460385	1461385	1461705	450	1035	705	625	1495	250	3,0	3,0	52,1	62,4
1460410	1461410	1461715	500	1135	780	675	1645	250	3,0	3,0	59,9	71,0

* Only supplied smooth.

The item numbers stated are for sliding dampers assembled using pull rings [f.b].

Sliding dampers are also available for other assembly methods. See p. 6 for assembly methods.

Sliding dampers, galvanised, manual

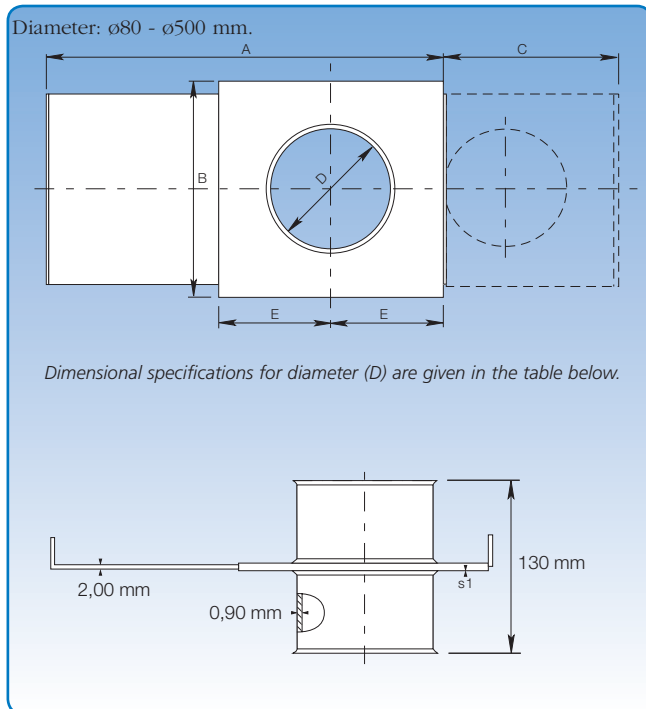

Dimensional specifications for integration length (L) are given in the table below.

Sliding dampers are made of 1.25 and 1.50 mm galvanised sheet metal with a damper of 2.00 mm galvanised sheet metal.

Item no. (Man.)	Dimensions						Weight kg
	D mm	s1 mm	A mm	B mm	C mm	E mm	
1470112	80	1,25	255	145	105	75	1,10
1471112	100	1,25	340	185	150	95	1,60
1472112	120	1,25	340	185	150	95	1,70
1473112	125	1,25	340	185	150	95	1,80
1474112	140	1,25	405	225	175	115	2,40
1475112	150	1,25	405	225	175	115	2,30
1476112	160	1,25	405	225	175	115	2,30
1477112	180	1,25	525	295	225	150	3,80
1478112	200	1,25	525	295	225	150	4,00
1479112	225	1,50	590	325	270	160	4,60
1480112	250	1,50	650	350	300	175	5,20
1480142	275	1,50	705	380	325	190	6,40
1481112	300	1,50	755	400	345	205	6,50
1481142	315	1,50	785	420	365	210	7,00
1482112	350	1,50	885	450	435	200	7,60
1483112	400	1,50	960	500	460	250	9,30
1485112	450	1,50	1050	550	500	275	10,70
1486112	500	1,50	1160	600	550	300	14,10

The item numbers stated are for sliding dampers assembled using pull rings [f.b].

Sliding dampers are also available for other assembly methods. See p. 6 for assembly methods.

Throttle valves, galvanised, manual, pneumatic and electric

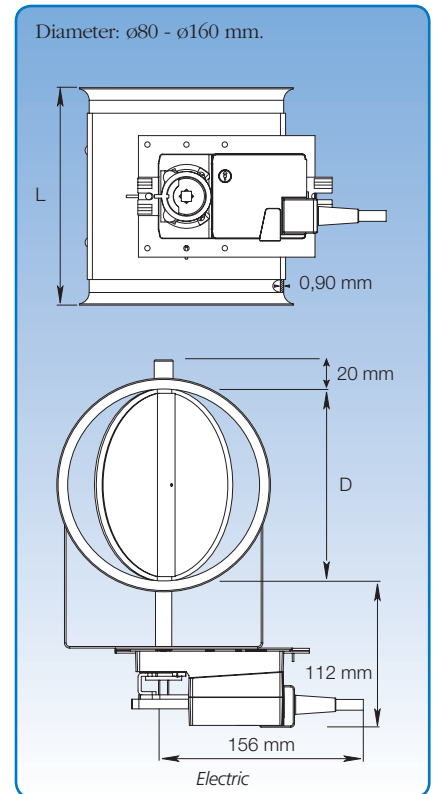
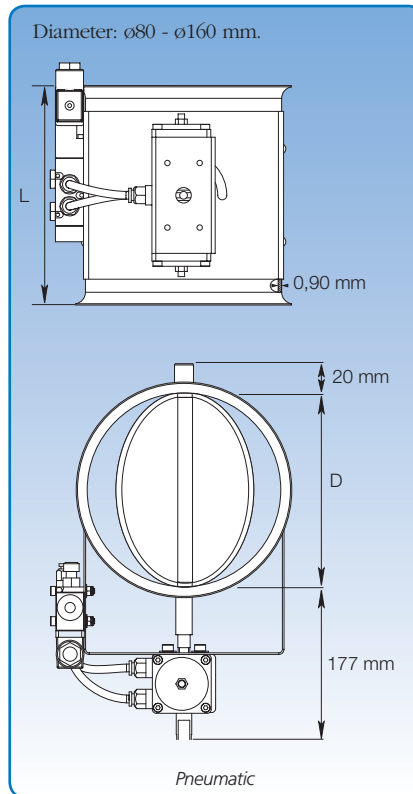
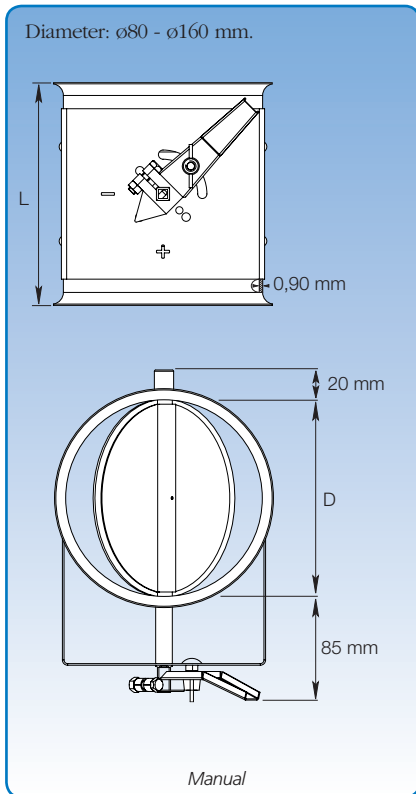

General

Galvanised throttle valves are made of 0,90 mm sheet metal and damper in double sheet. Throttle handle indicates damper position, and can be variably set between open and closed.

Available with natural rubber gasket.

Maximum closure 96%.

Larger throttle valves can be supplied upon request.

With pneumatic actuator

The damper is turned by a pneumatic actuator controlled by an electrically-operated valve.

Solenoid valve: monostable 5/2 valve with 1 x 230 V AC - 50/60 Hz electric coil or 24 V DC. Pneumatic pressure: 4-6 bar.

Valve setting indicators are available as an optional extra. Solenoid included as standard.

With electric actuator

The damper is operated by an electric motor activated by a changeover switch.

Valve setting indicators are available as an optional extra.

Electrical connection: 230 V AC - 50 Hz or 24 V DC.

Dimensions

Item no. (Man. stand)	Item no. (Man. tight)	Item no. (Pneu.)	Item no. (Elec.)	D mm	L mm	Weight (Man.) kg	Weight (Pneu.) kg	Weight (Elec.) kg
1570112	1510112	1510512	1510312	80	125	0,65	1,90	1,60
1571112	1511112	1511512	1511312	100	125	0,75	2,00	1,70
1572112	1512112	1512512	1512312	120	135	0,90	2,15	1,85
1573112	1513112	1513512	1513312	125	135	0,95	2,20	1,90
1574112	1514112	1514512	1514312	140	170	1,15	2,40	2,10
1575112	1515112	1515512	1515312	150	170	1,25	2,50	2,20
1576112	1516112	1516512	1516312	160	170	1,35	2,60	2,30

The item numbers stated are for throttle valves assembled using pull rings [f.b].

Throttle valves are also available for other assembly methods. See p. 6 for assembly methods.

Throttle valves, galvanised, manual, pneumatic and electric

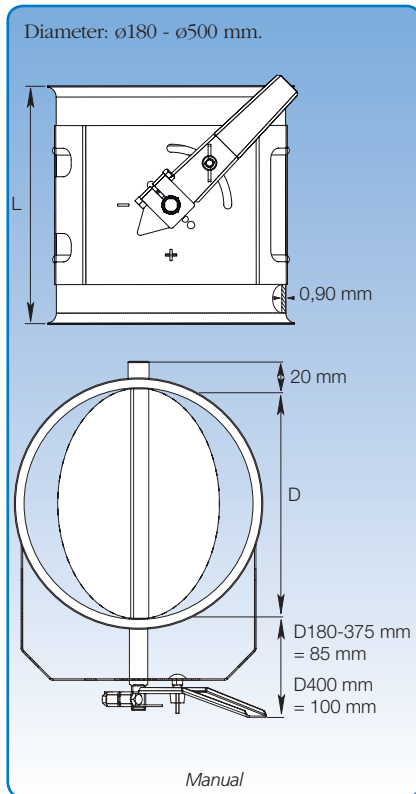

General

Throttle valves are made of 0.90 mm sheet metal and damper in double sheet. Throttle handle indicates damper position, and can be variably set between open and closed. Available with natural rubber gasket. Maximum closure 96%. Larger throttle valves can be supplied upon request.

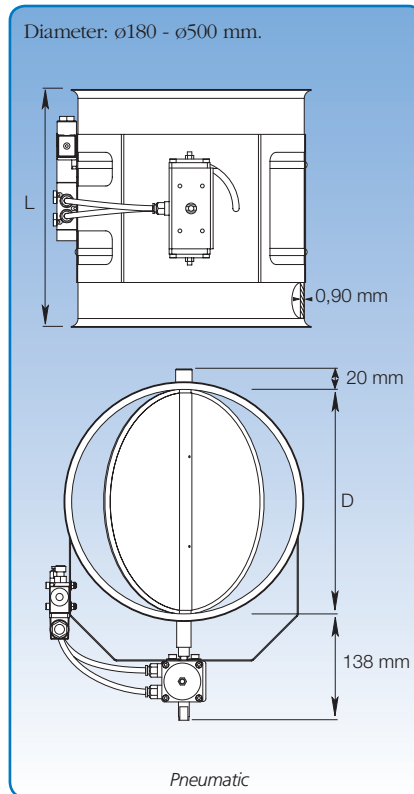

With pneumatic actuator

The damper is turned by a pneumatic actuator controlled by an electrically-operated valve. Solenoid valve: monostable 5/2 valve with 1 x 230 V AC - 50/60 Hz electric coil or 24 V DC. Pneumatic pressure: 4-6 bar. Valve setting indicators are available as an optional extra. Larger throttle valves can be made to order.

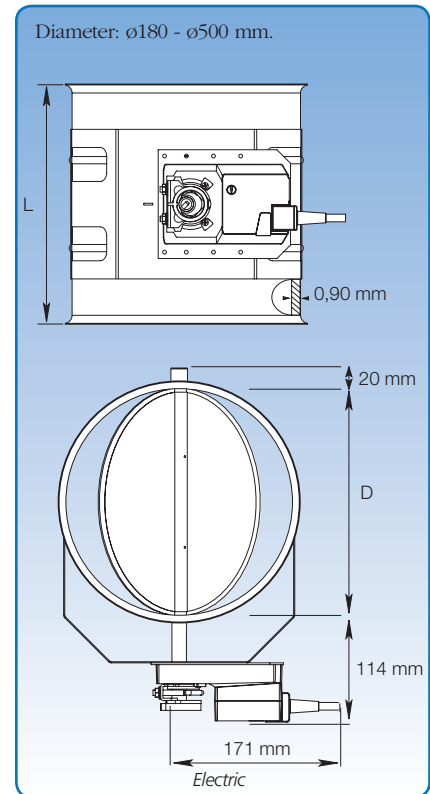

With electric actuator

The damper is operated by an electric motor activated by a changeover switch. Valve setting indicators are available as an optional extra. Electrical connection: 230 V AC - 50 Hz or 24 V DC. Larger throttle valves can be made to order.

Dimensions

Item no. (Man. stand)	Item no. (Man tight)	Item no. (Pneu.)	Item no. (Elec.)	D mm	L mm	Weight (Man.) kg	Weight (Pneu.) kg	Weight (Elec.) kg
1577112	1517112	1517512	1517312	180	210	1,90	2,85	3,55
1578112	1518112	1518512	1518312	200	210	2,20	3,15	3,85
1579112	1519112	1519512	1519312	225	240	2,55	3,60	4,20
1580112	1520112	1520512	1520312	250	265	3,05	4,00	5,05
1580142	1520612	1520912	1520712	275	290	3,50	4,50	5,50
1581112	1521112	1521512	1521312	300	315	4,30	5,20	6,30
1581142	1521612	1521912	1521712	315	330	4,30	5,50	6,50
1582112	1522112	1522512	1522312	350	365	4,77	6,30	6,50
1583112	1523112	1523512	1523312	400	415	5,50	7,60	7,50
1584112	1524112	1524512	1524312	450	465	6,10	9,30	9,70
1585112	1525112	1525512	1525312	500	515	13,10	11,03	11,45

The item numbers stated are for throttle valves assembled using pull rings [f.b].

Throttle valves are also available for other assembly methods. See p. 6 for assembly methods.

60° branch diverters, pressed, manual, pneumatic and electric

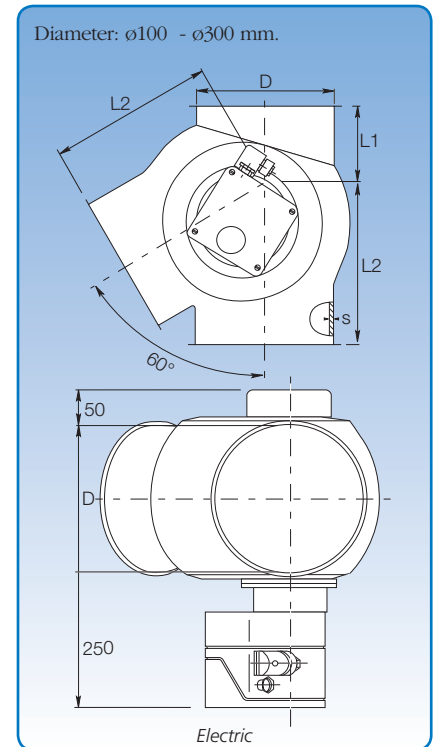
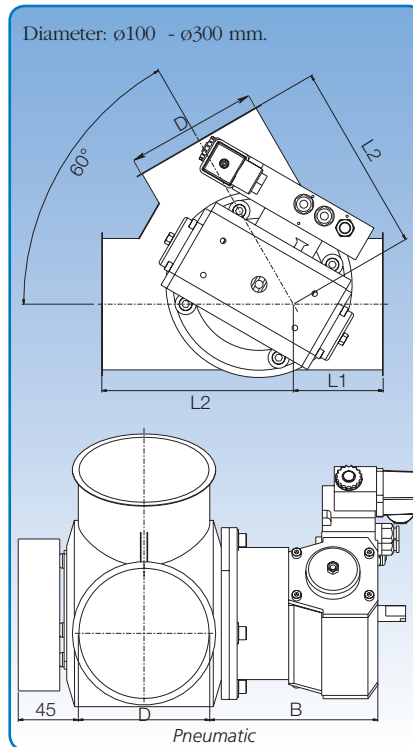
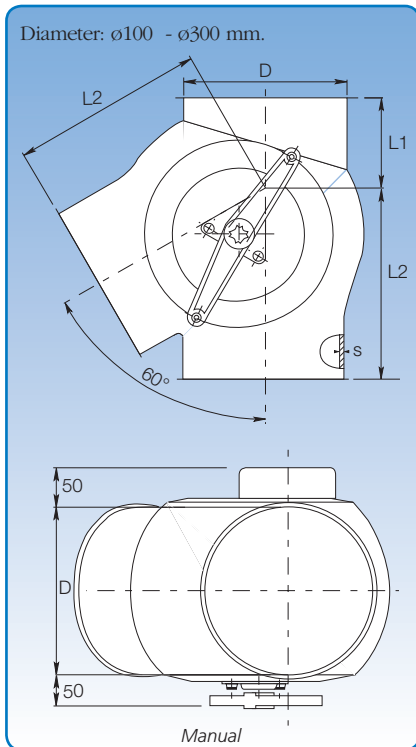

Dimensional specifications are given in the table below.

General

60° branch diverters, pressed, designed for falling and forced direction transport.
Damper suspended on brass bearings.
Supplied as standard with left branch.

With pneumatic actuator

The damper is turned by a pneumatic actuator controlled by an electrically-operated valve.
Solenoid valve: monostable 5/2 valve with 1 x 230 V AC - 50/60 Hz electric coil or 24 V DC. Pneumatic pressure: 4-6 bar.
Valve setting indicators are available as an optional extra.

With electric actuator

The damper is operated by an electric motor activated by a changeover switch.
Electrical connection: 230 V AC - 50 Hz or 24 V DC.
Valve setting indicators are supplied as standard.

Dimensions										
Item no. (Man.)	Item no. (Pneu.)	Item no. (Elec.)	D mm	s mm	B mm	L1 mm	L2 mm	Weight (Man.) kg	Weight (Pneu.) kg	Weight (Elec.) kg
1700036	1720036	1710036	100	1,50	145	70	145	2,20	5,20	6,90
1701036	1721036	1711036	120	1,50	145	160	240	6,00	9,00	10,70
1702036	1722036	1712036	125	1,50	145	90	170	4,00	7,00	8,70
1703036	1723036	1713036	150	2,00	145	100	190	5,70	8,70	10,40
1704036	1724036	1714036	160	2,00	145	95	225	6,10	9,10	10,80
1705036	1725036	1715036	180	2,00	145	195	315	11,00	14,00	15,70
1706036	1726036	1716036	200	2,00	145	110	230	8,30	11,30	13,00
1707036	1727036	1717036	250	2,00	145	135	270	13,10	16,10	17,90
1708036	1727336	1717336	300	2,00	145	160	325	19,30	22,30	24,10

The item numbers stated are for branch diverters assembled using pull rings [f.b].

Branch diverters are also available for other assembly methods. See p. 7 for assembly methods.

45° branch diverters, pressed, manual

Suggestion for use of JKF bends. Example shows a trouser diverter and two 15° bends.

Pressed diverters are made of 1.50 - 2.00 mm sheet metal (s) with a standard 2.00 mm damper suspended on brass bearings.

Supplied as standard with left branch.

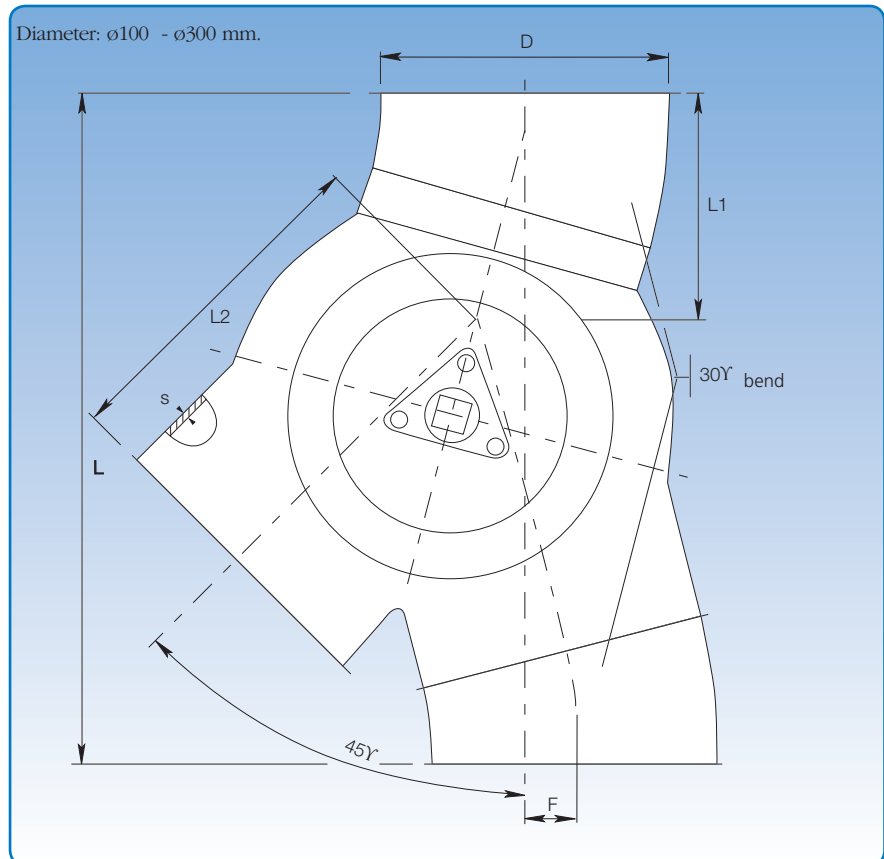

Dimensional specifications are given in the table below.

Dimensions							
D mm	s mm	F mm	L mm	L1 mm	L2 mm	Weight kg	
100	1,50	25	270	100	145	2,80	
120	1,50	25	380	145	240	5,90	
125	1,50	25	335	120	170	5,30	
150	2,00	30	375	135	190	7,80	
160	2,00	40	410	130	225	7,80	
180	2,00	40	600	230	315	13,40	
200	2,00	40	455	155	230	11,30	
250	2,00	35	550	190	270	17,70	
300	2,00	55	660	230	325	25,90	

45° branch diverters, manual, pneumatic and electric

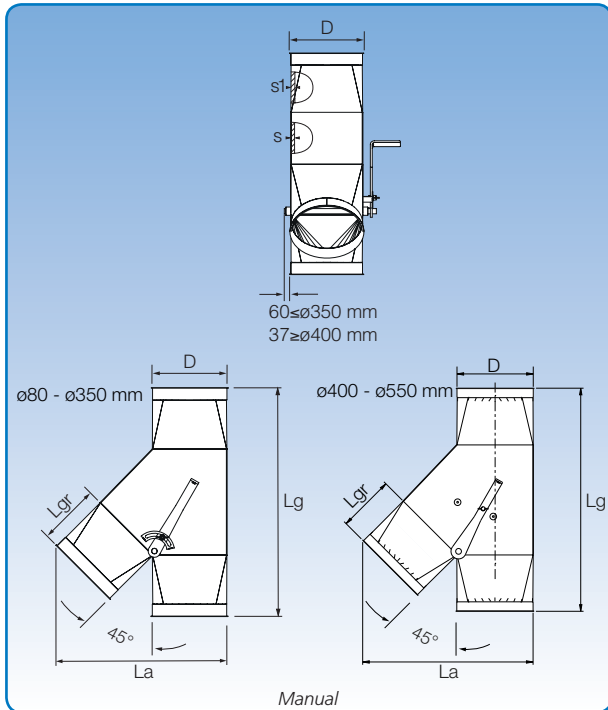

Manual

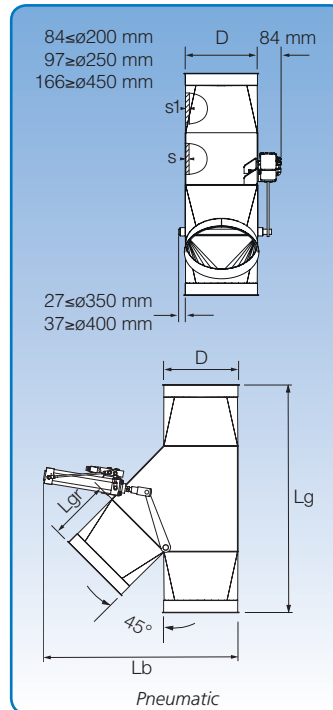

Pneumatic

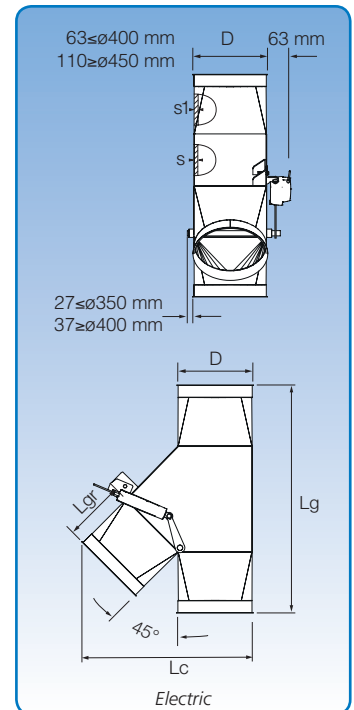

Electric

General

Diameter: ø80 - ø550 mm.
 Designed for falling and pneumatic transport.
 Available with rubber gasket on damper plate for pneumatic transport.
 Damper suspended on nylon bearings.
 Supplied as standard with left branch.

With pneumatic actuator

The damper is turned by a pneumatic cylinder controlled by an electrically-operated valve.
 Solenoid valve: monostable 5/2 valve with 1 x 230 V AC – 50/60 Hz electric coil or 24 V DC.
 Pneumatic pressure: 4-6 bar. Valve setting indicators are available as an optional extra.

With electric actuator

The damper is operated by an electric motor activated by a changeover switch.
 Power supply: 24 V DC with build in CS-print guarding against over-current. Switch box with damper setting indicators available as an optional extra.

Dimensions

Item no. (Man.)	Item no. (Pneu.)	Item no. (Elec.)	D mm	s mm	s1 mm	Damper plate mm	Lg mm	La mm	Lb mm	Lc mm	Lgr mm	Weight (Man.) kg	Weight (Pneu.) kg	Weight (Elec.) kg
1700016	1740063	1710063	80*	3,00	2,00	4,00	385	257	334	257		4,6	6,2	5,4
1700064	1740064	1710064	100	3,00	2,00	4,00	383	266	338	266	105	4,8	6,4	5,6
1701064	1741064	1711064	120*	3,00	2,00	4,00	422	305	395	305	110	6,4	8,1	7,1
1702064	1742064	1712064	125	3,00	2,00	4,00	422	312	395	312	110	6,6	8,1	7,4
1702164	1742964	1712964	140*	3,00	2,00	5,00	514	367	524	367	145	8,9	11,3	9,7
1703064	1743064	1713064	150	3,00	2,00	5,00	508	371	527	371	145	9,0	11,4	9,8
1704064	1744064	1714064	160	3,00	2,00	5,00	514	383	527	383	145	9,3	11,6	10,0
1705064	1745064	1715064	180*	3,00	2,00	5,00	583	441	656	441	145	16,3	18,8	17,0
1706064	1746064	1716064	200	3,00	2,00	5,00	583	459	663	459	145	16,6	19,0	17,4
1707064	1747064	1717064	250	3,00	2,00	6,00	864	610	710	610	250	27,3	30,9	28,0
1708064	1747364	1717364	300	4,00	3,00	6,00	934	693	794	653	250	35,9	39,2	36,7
1708564	1747564	1717564	315*	4,00	3,00	6,00	1018	751	884	751	250	47,6	50,7	48,4
1709064	1747664	1717664	350	4,00	3,00	6,00	1018	782	884	782	250	48,3	51,3	49,0
1709264	1747964	1717964	400	4,00	3,00	6,00	1180	898	961	898	295	65,3	67,0	67,9
1709364	1748064	1718064	450	4,00	3,00	6,00	1234	983	985	983	295	89,5	93,7	91,7
1709464	1748364	1718364	500	4,00	3,00	6,00	1325	1067	1070	1067	295	113,0	116,7	115,2
1709564	1748664	1718664	550	4,00	3,00	6,00	1397	1152	1155	1152	345	131,3	134,8	133,5

The item numbers stated are for branch diverters assembled using pull rings (f.b).

Branch diverters are also available for other assembly methods. See p. 7 for assembly methods.

* Diverter delivered with rubber gasket Lg+50 mm extra.

60° trouser diverters, pressed, manual, pneumatic and electric

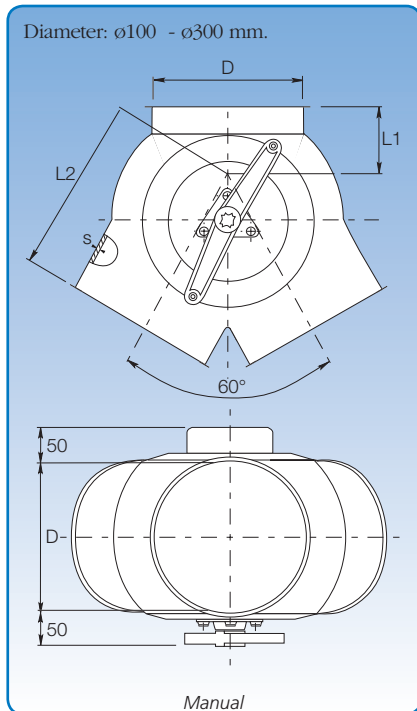

Dimensional specifications are given in the table below.

General

Trouser diverters, pressed, are designed for falling and forced direction transport. Pressed diverters are made of 1.50 - 2.00 mm sheet metal (s) with a standard 2.00 mm damper suspended on brass bearings.

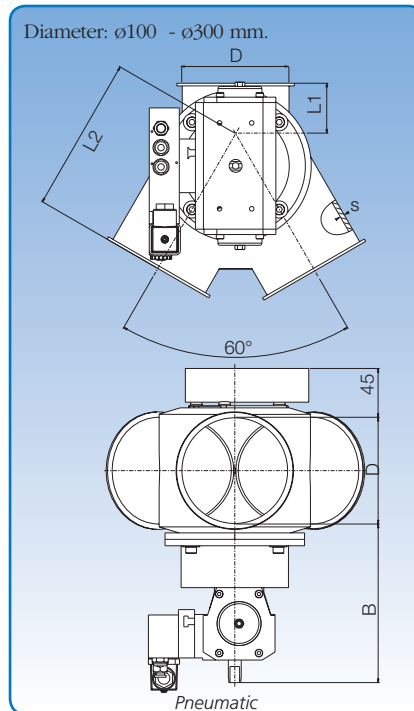

Dimensional specifications are given in the table below.

With pneumatic actuator

The damper is turned by a pneumatic actuator controlled by an electrically-operated valve. Solenoid valve: monostable 5/2 valve with 1 x 230 V AC - 50/60 Hz electric coil or 24 V DC. Pneumatic pressure: 4-6 bar. Valve setting indicators are available as an optional extra.

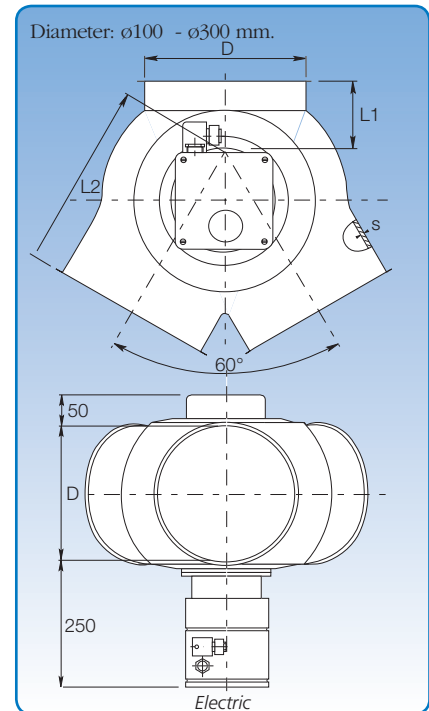

Dimensional specifications are given in the table below.

With electric actuator

The damper is operated by an electric motor activated by a changeover switch. Power supply: 230 V AC - 50 Hz or 24 V DC. Switch box with damper setting indicators supplied as standard. Not supplied with profile for damper plate.

Dimensions										
Item no. (Man.)	Item no. (Pneu.)	Item no. (Elec.)	D mm	s mm	B mm	L1 mm	L2 mm	Weight (Man.) kg	Weight (Pneu.) kg	Weight (Elec.) kg
1700037	1720037	1710037	100	1,50	145	70	145	2,00	5,00	6,70
1701037	1721037	1711037	120	1,50	145	160	240	4,70	7,80	9,40
1702037	1722037	1712037	125	1,50	145	90	170	3,90	6,90	8,60
1703037	1723037	1713037	150	2,00	145	100	190	5,60	8,80	10,50
1704037	1724037	1714037	160	2,00	145	95	225	5,60	8,50	10,30
1705037	1725037	1715037	180	2,00	145	195	315	10,60	13,70	15,30
1706037	1726037	1716037	200	2,00	145	110	230	7,90	10,90	12,60
1707037	1727037	1717037	250	2,00	185	135	270	12,50	15,50	17,30
1708037	1727337	1717337	300	2,00	185	160	325	18,25	21,30	23,10

The item numbers stated are for trouser diverters assembled using pull rings [f.b].

Trouser diverters are also available for other assembly methods. See p. 7 for assembly methods.

60° trouser diverters, welded, manual, pneumatic and electric

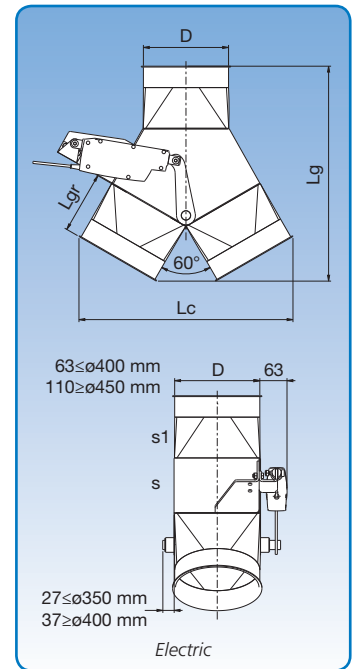
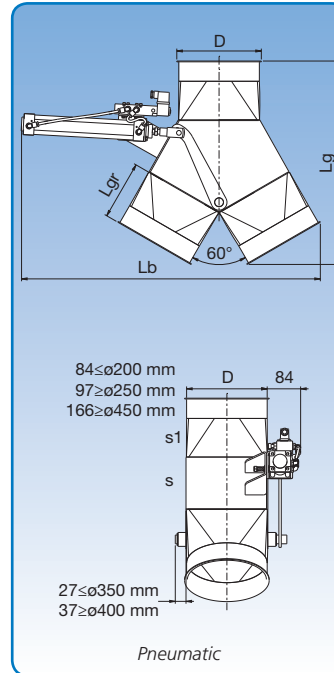
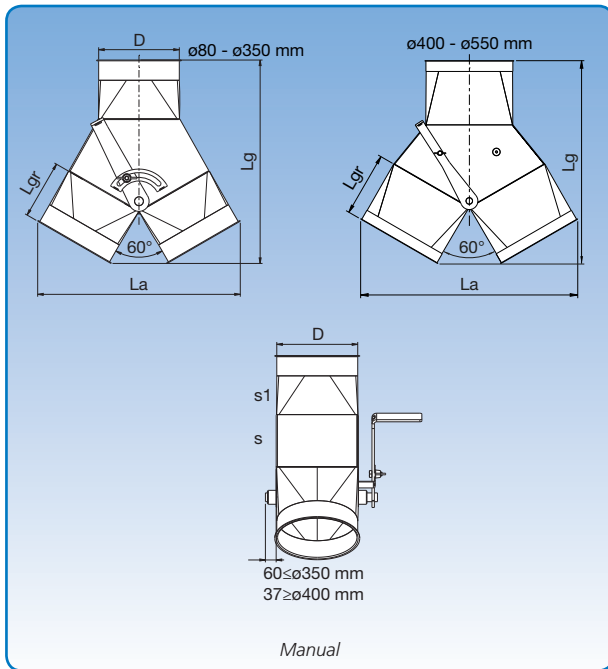

Dimensional specifications are given in the table below.

General

Diameter: ø80 - ø550 mm.
 Designed for falling and pneumatic transport.
 Available with rubber gasket on damper plate for pneumatic transport.
 Damper suspended on nylon bearings.

With pneumatic actuator

The damper is turned by a pneumatic cylinder controlled by an electrically-operated valve.
 Solenoid valve: monostable 5/2 valve with 1 x 230 V AC - 50/60 Hz electric coil or 24 V DC. Pneumatic pressure: 4-6 bar. Valve setting indicators are available as an optional extra.

With electric actuator

The damper is operated by an electric motor activated by a changeover switch.
 Power supply: 24 V DC with build in CS-print guarding against over-current. Switch box with damper setting indicators available as an optional extra.

Dimensions

Item no. (Man.)	Item no. (Pneu.)	Item no. (Elec.)	D mm	s mm	s1 mm	Damper plate mm	Lg mm	La mm	Lb mm	Lc mm	Lgr mm	Weight (Man.) kg	Weight (Pneu.) kg	Weight (Elec.) kg
1700017	1740967	1710967	80*	3,00	2,00	4,00	335	308	423		105	3,6	5,6	5,7
1700067	1740067	1710067	100	3,00	2,00	4,00	335	308	423	449	105	4,0	5,9	6,0
1701067	1741067	1711067	120*	3,00	2,00	4,00	362	353	470		110	4,3	6,2	9,4
1702067	1742067	1712067	125	3,00	2,00	4,00	362	353	470		110	5,4	7,3	8,6
1702167	1742967	1712967	140*	3,00	2,00	5,00	465	426	630	530	145	7,8	10,6	9,9
1703067	1743067	1713067	150	3,00	2,00	5,00	465	426	630	530	145	8,0	10,7	9,9
1704067	1744067	1714067	160	3,00	2,00	5,00	465	426	630	530	145	8,1	10,9	10,0
1705067	1745067	1715067	180*	3,00	2,00	5,00	512	510	753	562	145	11,5	14,5	13,5
1706067	1746067	1716067	200	3,00	2,00	5,00	512	510	753	562	145	12,0	15,0	14,0
1707067	1747067	1717067	250	3,00	2,00	5,00	770	703	854	703	250	23,6	27,7	25,1
1708067	1747367	1717367	300	3,00	2,00	5,00	818	786	942	787	250	30,2	33,5	30,8
1708567	1747567	1717567	315*	3,00	2,00	6,00	873	876	991	925	250	38,1	39,7	42,3
1709067	1747667	1717667	350	3,00	2,00	6,00	873	876	991	925	250	38,7	39,9	42,5
1709267	1747967	1717967	400	3,00	2,00	6,00	943	1008	1040	1008	295	48,8	52,0	52,9

The item numbers stated are for trouser diverters assembled using pull rings (f.b).

Branch diverters are also available for other assembly methods. See p. 7 for assembly methods.

* Diverter delivered with rubber gasket Lg+50 mm extra.

False air valves, galvanised

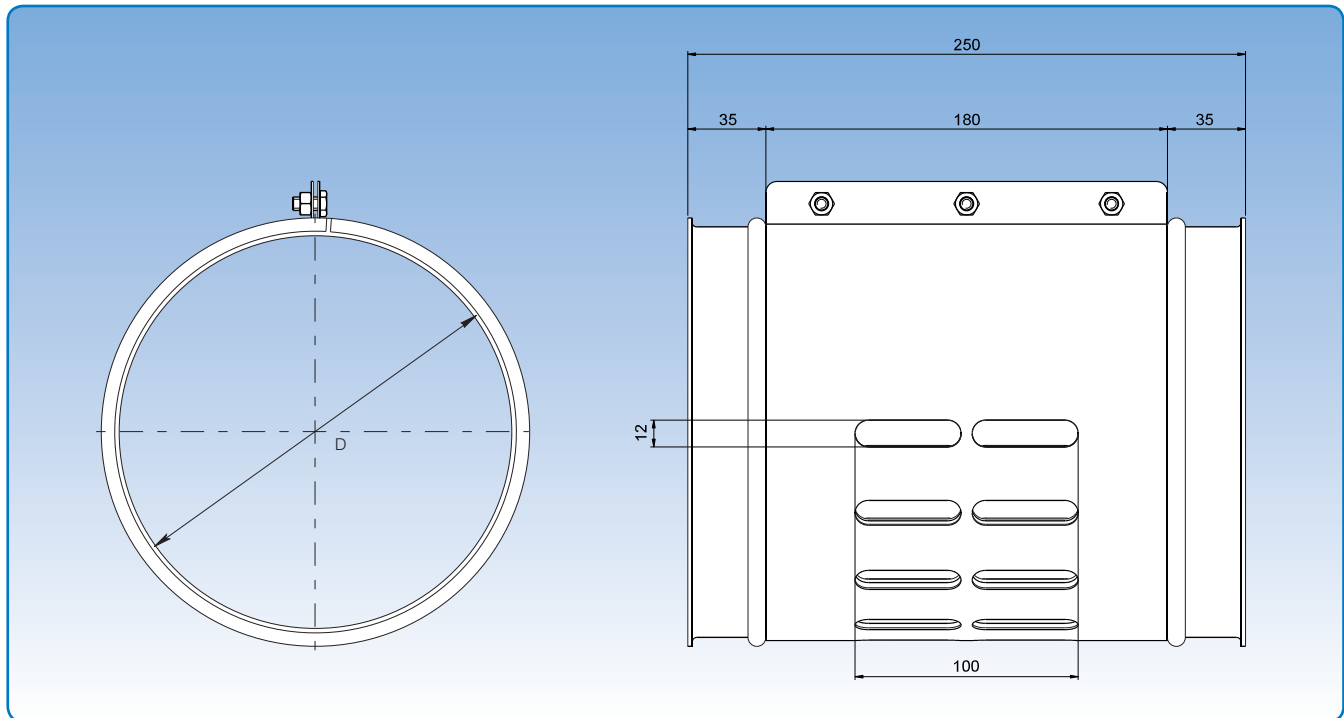

Diameter: $\varnothing 80 - \varnothing 400$ mm.

Made of 0.90 mm sheet metal.

"False" air is regulated by turning the external button.

Item no.	Dimensions		Weight kg
	D mm		
90500001	80		0,95
90500002	100		1,60
90500003	120		0,90
9050000301	125		0,95
905000031	140		1,65
905000032	150		1,25
905000033	160		1,95
905000034	180		2,20
905000035	200		2,45
905000036	225		2,80
905000037	250		3,15
905000038	275		3,50
905000039	300		3,85
9050000391	315		4,30
9050000392	350		4,78
9050000393	400		5,60

The item numbers stated are for false air valves assembled using pull rings [f.b].

False air valves are also available for other assembly methods. See p. 6 for assembly methods.

Pull rings, galvanised

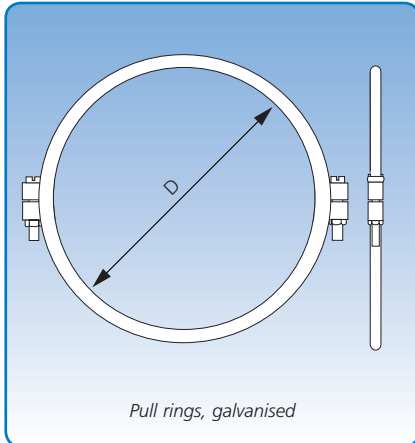

Pull rings, galvanised

Diameter: $\varnothing 80 - \varnothing 500$ mm.

Galvanised pull rings [f.b] are in two pieces.

Pull rings are electro-galvanised.

EPDM rubber rings are available as optional extras for sealing $\varnothing 80 - \varnothing 300$ mm diameter assemblies.

They are supplied in plastic bags of 10, along with the necessary nuts and bolts.

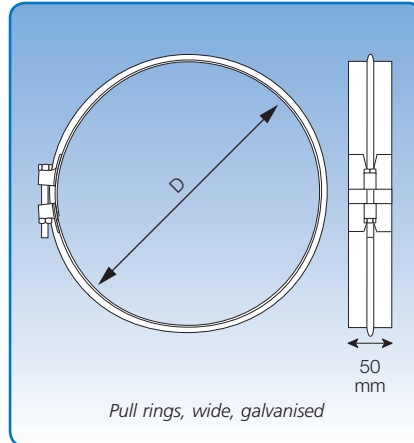

Pull rings, wide, galvanised

Diameter: $\varnothing 150 - \varnothing 1000$ mm.

Wide galvanised pull rings [f.bb] are made from hot dip galvanised sheet metal.

These rings are supplied individually with nuts and bolts.

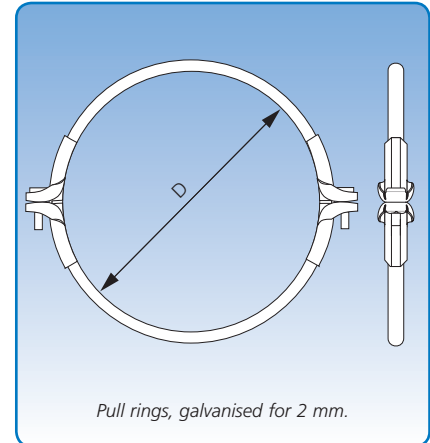

Pull rings, galvanised for 2 mm.

Diameter: $\varnothing 80 - \varnothing 600$ mm.

Galvanised pull rings [f.b] are in two pieces.

Pull rings are electro-galvanised.

Insert with sealing compound

JKF supplies pull rings with sealing compound inserted, made of Terostat VII material. The insert has a protective plastic film which must be removed before the pull ring can be used.

The sealing compound is not soluble. Working temperature range is -50°C to $+100^{\circ}\text{C}$. The rings are supplied in plastic bags of 10, along with the necessary nuts and bolts.

Pull rings, galv.		
Item no.	D mm	10 pcs. Weight kg
1670011	80	0,55
1671011	100	0,60
1672011	120	0,65
1673011	125	0,70
1674011	140	0,75
1675011	150	0,80
1676011	160	0,83
1677011	180	0,85
1678011	200	0,90
1679011	225	0,95
1680011	250	1,00
1680511	275	1,05
1681011	300	1,25
1682011	315	1,30
1682611	325	1,30
1683011	350	1,35
1684011	400	1,45
1684711	425	1,50
1685011	450	1,65
1686011	500	1,90

Pull rings, wide, galvanised.		
Item no.	D mm	Pce. Weight kg
1675001	150	0,22
1676001	160	0,23
1677001	180	0,24
1678001	200	0,25
1679001	225	0,30
1680001	250	0,35
1680501	275	0,40
1681001	300	0,45
1682001	315	0,47
1682601	325	0,49
1683001	350	0,50
1683701	375	0,52
1684001	400	0,55
1684701	425	0,55
1685001	450	0,60
1685901	475	0,60
1686001	500	0,65
1686501	525	0,65
1687001	550	0,70
1688001	600	0,70
1689001	630	0,70
1690001	650	0,75
1691001	700	0,80
1692001	750	0,85
1693001	800	0,90
1694001	850	0,95
1695001	900	1,00
1696001	950	1,05
1697001	1000	1,10

Pull rings, 2 mm, galv.		
Item no.	D mm	10 pcs. Weight kg
Rubber ring insert (EPDM)		
1670021	80	1,76
1671021	100	1,87
1672021	120	2,04
1673021	125	2,21
1674021	140	2,25
1675021	150	2,38
1676021	160	2,55
1677021	180	2,72
1678021	200	2,83
1679021	225	3,20
1680021	250	3,40
1680521	275	3,45
1681021	300	3,57
Insert with sealing compound		
1682021	315	4,25
1683021	350	4,42
1684021	400	4,93
1685021	450	5,61
1686021	500	6,46
1687021	550	7,14
1688021	600	8,50

Rubber gasket rings

Diameter: $\varnothing 80$ - $\varnothing 300$ mm.

Standard rubber gasket rings are made of EPDM 80 rubber and used for f.b. assemblies to improve degree of tightness.

One ring is fitted for each assembly.
Rings are fitted on either f.b. edge before assembly.

Rubber gasket rings are U-shaped in cross section.
Hardness is 80 shore, and working temperature range is -40°C to $+100^{\circ}\text{C}$.

Same dimensions are available in NITRIL rubber.
Hardness is 80 shore, and working temperature range is -15°C to $+80^{\circ}\text{C}$.

NITRIL rubber is resistant to oil and petrol, and to some degree to acids and bases.

Supplied in plastic bags of 10 pcs.

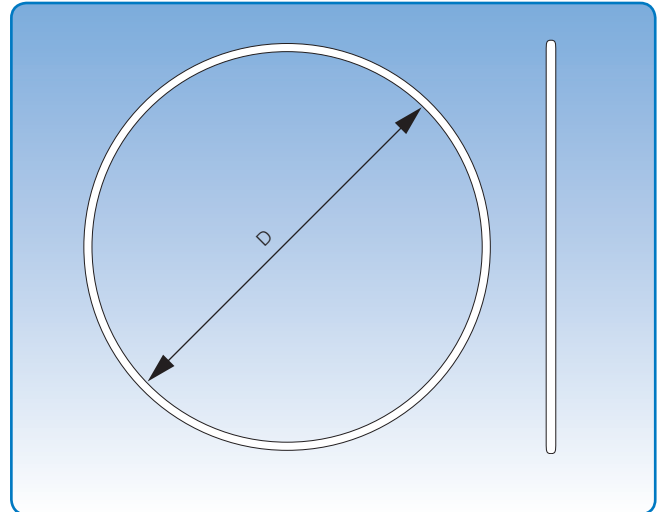

Dimensional specifications are given in the table below.

Item no.	Dimensions	
	D mm	Weight/10 pcs. kg
820170080	80	0,20
820170100	100	0,30
820170120	120	0,50
820170125	125	0,50
820170140	140	0,60
820170150	150	0,60
820170160	160	0,70
820170180	180	0,70
820170200	200	0,80
820170225	225	1,10
820170250	250	1,12
820170275	275	1,12
820170300	300	1,30

Rapid lock pull rings, galvanised

Rapid lock pull rings [f.lyn] are electro-galvanised and used for fast, tight assembly of duct systems.

Fitted with an insert which provides a dust-resistant join and provides stability to the duct system, ensuring electrical conductivity through the assembly.

2 and 3 mm duct systems are fitted with a rapid lock pull ring with an insert which facilitates a larger size.

A silicon insert is required for temperatures above 80°C, which can tolerate temperatures up to 275°C.

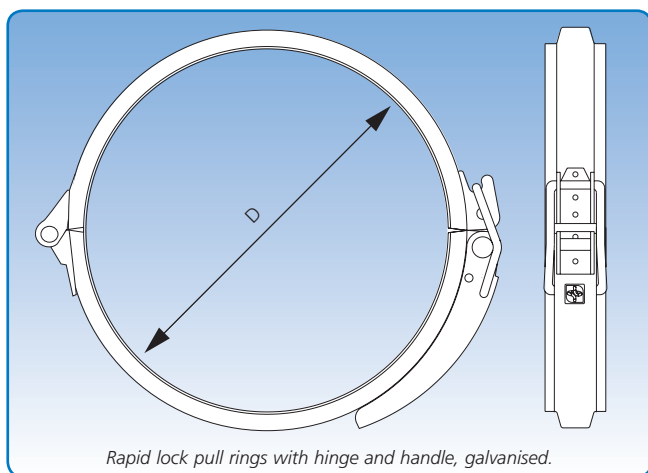

Diameter: $\varnothing 80 - \varnothing 400$ mm.

Handle is extended and made of a strong material for hand operation of rapid lock pull rings. The powerful steel spring ensures high quality opening/closing mechanism and long service life.

Supplied individually.

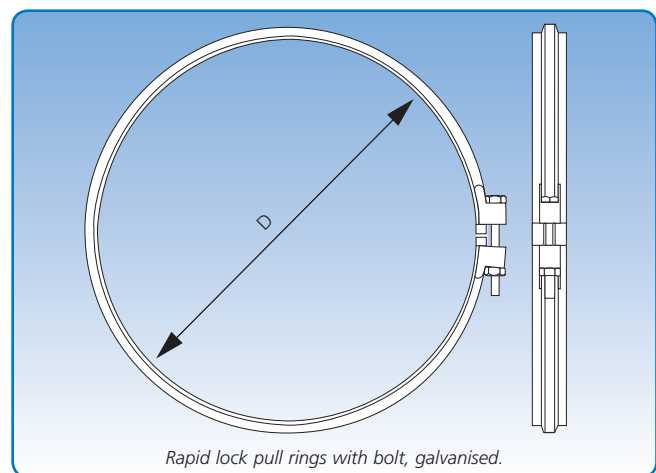

Diameter: $\varnothing 425 - \varnothing 800$ mm. To max. $\varnothing 600$ mm diameter in 2.00-3.00 mm.

Supplied individually with nuts and bolts.

Rapid lock pull rings with hinge and handle, galvanised.

Item no.	D mm	Weight kg
1670013	80	0,19
1671013	100	0,21
1672013	120	0,23
1673013	125	0,24
1674013	140	0,25
1675013	150	0,26
1676013	160	0,28
1677013	180	0,30
1678013	200	0,32
1679013	225	0,34
1680013	250	0,37
1680513	275	0,39
1681013	300	0,42
1682013	315	0,44
1682613	325	0,45
1683013	350	0,48
1683613	355	0,48
1683713	375	0,51
1684013	400	0,53

Rapid lock pull rings with bolt, galvanised.

Item no.	D mm	Weight kg
1684712	425	0,56
1685012	450	0,58
1685912	475	0,61
1686012	500	0,63
1687012	550	0,68
1688012	600	0,73
1689012	630	0,79
1690012	650	0,81
1691012	700	0,88
1692012	750	0,94
1693012	800	1,00

Flanges

Diameter: $\varnothing 80$ - $\varnothing 1250$ mm.

Flanges are made in accordance with JKF's standard, and are a standard component in the product range.

Flanges are stock items in hot dip galvanised finish, but can be supplied either untreated or painted.

Flanges in other dimensions or profiles are available to order.

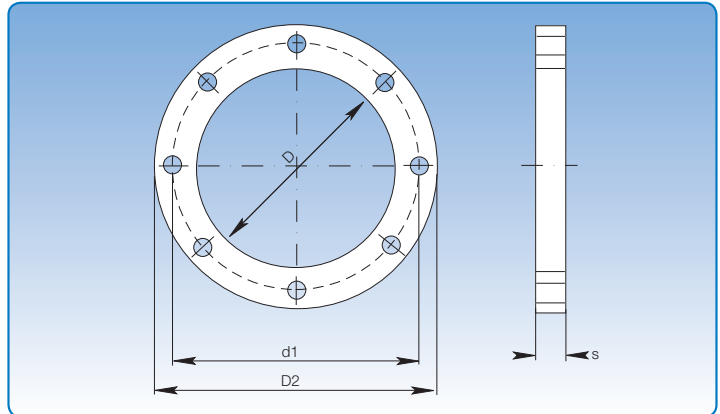

Dimensional specifications are given in the table below.

Item no.	Dimensions								
	Diameter: nominal	D mm	d1 mm	D2 mm	s mm	Flange width mm	Hole size mm	Quant. holes	Weight kg
1670005	80	85	115	135	3,00	25	10	8	0,19
1671005	100	105	135	155	3,00	25	10	8	0,23
1672005	120	125	155	175	3,00	25	10	8	0,26
1673005	125	130	160	180	3,00	25	10	8	0,27
1674005	140	143	175	193	3,00	25	10	8	0,30
1675005	150	155	185	205	5,00	25	10	8	0,53
1676005	160	165	195	215	5,00	25	10	8	0,56
1677005	180	185	215	235	5,00	25	10	8	0,62
1678005	200	205	235	255	5,00	25	10	12	0,67
1679005	225	230	260	280	5,00	25	10	12	0,74
1680005	250	255	285	305	5,00	25	10	12	0,83
1680505	275	280	310	330	5,00	25	10	12	0,90
1681005	300	305	336	355	5,00	25	10	12	0,97
1682005	315	320	351	370	5,00	25	10	12	1,22
1683505	325	330	360	380	5,00	25	10	12	1,06
1683005	350	355	389	415	5,00	30	12	12	1,36
1684505	375	380	424	440	6,00	30	12	12	1,74
1684005	400	405	439	465	6,00	30	12	16	1,85
1685505	425	430	462	490	6,00	30	12	16	1,96
1685005	450	455	489	515	6,00	30	12	16	2,05
1686505	475	480	515	540	6,00	30	12	16	2,16
1686005	500	505	540	565	6,00	30	12	16	2,28
1687005	550	555	590	615	6,00	30	12	16	2,51
1688005	600	605	640	665	6,00	30	12	16	2,73
1689005	630	635	670	695	6,00	30	12	24	2,83
1690005	650	655	690	715	6,00	30	12	24	2,89
1691005	700	705	750	785	6,00	40	12	24	4,26
1692005	750	755	800	835	6,00	40	12	24	4,56
1693005	800	805	850	885	6,00	40	12	24	4,85
1694005	850	855	900	935	6,00	40	12	24	5,15
1695005	900	905	950	985	6,00	40	12	24	5,43
1696005	950	955	1000	1035	6,00	40	12	24	5,73
1697005	1000	1005	1050	1085	6,00	40	12	24	6,02
1697505	1100	1105	1147	1185	6,00	40	12	28	6,56
1697705	1150	1155	1197	1235	6,00	40	12	28	6,85
1698505	1200	1205	1247	1285	6,00	40	12	24	7,18
1698005	1250	1255	1300	1335	6,00	40	12	28	7,44

Rubber flanges

Diameter: $\varnothing 80$ - $\varnothing 1250$ mm.

Rubber flanges are made of NITRIL rubber, adapted to JKF's standard flange range.

Hardness: 65 shore.

Temperature range: -10°C to $+70^{\circ}\text{C}$.

Resistant to oil and petrol and to a limited extent acid and base chemicals.

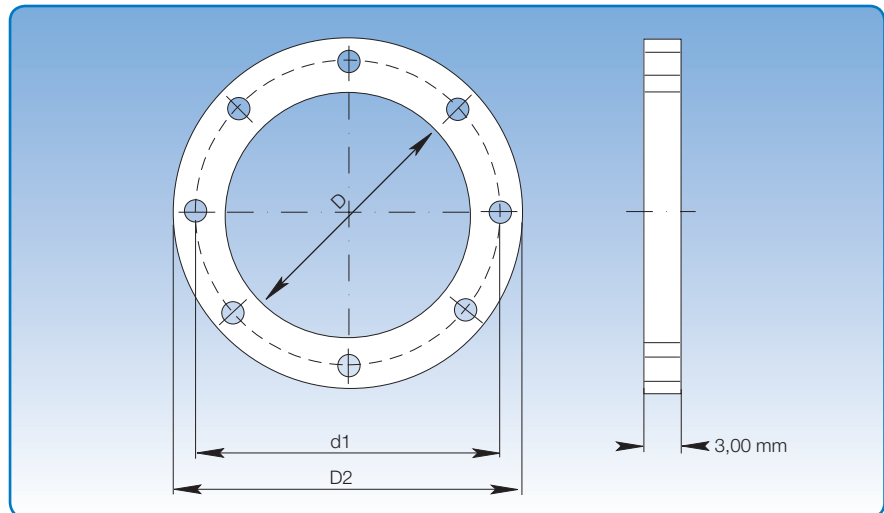

Dimensional specifications are given in the table below.

Item no.	Dimensions						Quant. holes	Weight kg
	Diameter nominal	D mm	d1 mm	D2 mm	Flange width mm	Hole size mm		
820150080	80	83	115	133	25	8	8	0,02
820150100	100	103	135	153	25	8	8	0,03
820150120	120	123	155	173	25	8	8	0,04
820150125	125	128	160	178	25	8	8	0,05
820150140	140	143	175	193	25	8	8	0,05
820150150	150	155	185	205	25	8	8	0,06
820150160	160	165	195	215	25	8	8	0,06
820150180	180	185	215	235	25	8	8	0,07
820150200	200	205	235	255	25	8	12	0,08
820150225	225	230	260	280	25	8	12	0,09
820150250	250	255	285	305	25	8	12	0,10
820150275	275	280	310	330	25	8	12	0,10
820150300	300	305	336	355	25	8	12	0,11
820150315	315	320	351	370	25	8	12	0,13
820150350	350	355	389	415	26	10	12	0,15
820150400	400	405	439	465	30	10	16	0,18
820150450	450	455	489	515	30	10	16	0,21
820150500	500	505	540	565	30	10	16	0,22
820150550	550	555	590	615	30	10	16	0,25
820150600	600	605	640	665	30	10	16	0,29
820150630	630	635	670	695	30	10	24	0,33
820150650	650	655	690	715	30	10	24	0,35
820150700	700	705	750	785	40	10	24	0,38
820150750	750	755	800	835	40	10	24	0,41
820150800	800	805	850	885	40	10	24	0,49
820150850	850	855	900	935	40	10	24	0,52
820150900	900	905	950	985	40	10	24	0,54
820150950	950	955	1000	1035	40	10	24	0,55
820151000	1000	1005	1050	1085	40	10	24	0,56
820151100	1100	1105	1147	1185	40	10	28	0,59
820151200	1200	1205	1247	1285	40	10	24	0,61
820151250	1250	1255	1300	1335	40	10	28	0,62

Jet caps, galvanised

Diameter: $\phi 120$ - $\phi 1000$ mm.

Supplied with the same JKF assembly methods as duct systems.

Jet caps from diameter $\phi 700$ - $\phi 1000$ mm are fitted with flanges as standard.

Jet caps are fitted with an internal cone and drain hose for disposal of water.

See next page for pressure loss curves.

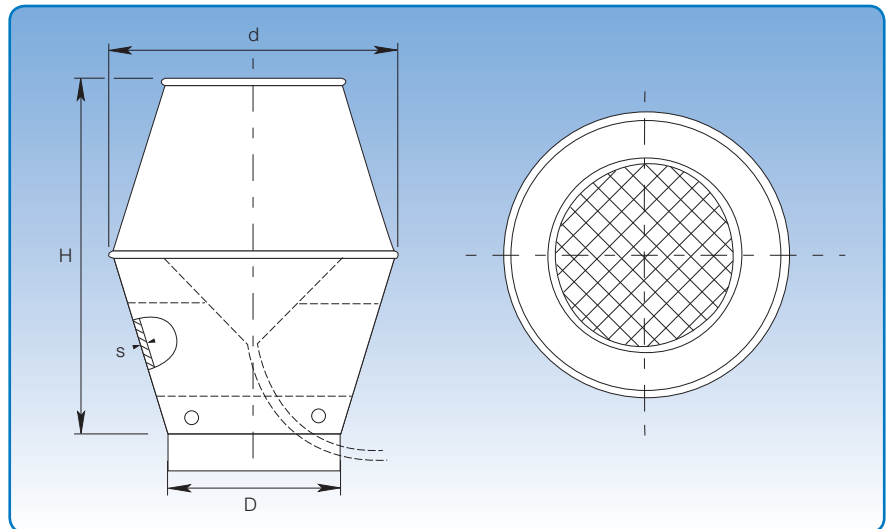

Dimensional specifications are given in the table below.

Dimensions					
Item no.	D mm	d mm	s mm	H mm	Weight kg
1902202	120	185	0,75	325	3,00
1903202	125	195	0,75	340	3,50
1904202	140	215	0,75	365	3,80
1905202	150	230	0,90	390	4,00
1906202	160	245	0,90	410	5,00
1907202	180	275	0,90	445	5,40
1908202	200	305	0,90	490	4,00
1909202	225	345	0,90	535	4,80
1910202	250	380	0,90	590	5,70
1912202	275	420	0,90	640	9,00
1913202	300	460	0,90	690	8,00
1914202	315	480	0,90	720	8,70
1915202	350	535	0,90	785	10,70
1916202	400	610	0,90	885	13,50
1917202	450	690	0,90	985	16,70
1918202	500	765	0,90	1095	21,00
1919202	550	840	0,90	1200	28,00
1920202	600	915	0,90	1300	36,00
1921202	630	960	0,90	1360	40,00
1922202	650	990	0,90	1390	42,00
1923202	700	1070	1,25	1505	49,00
1924202	750	1145	1,25	1595	56,00
1925202	800	1220	1,25	1695	68,00
1926202	850	1295	1,25	1795	80,00
1927202	900	1375	1,25	1900	100,00
1928202	950	1450	1,25	1975	105,60
1929202	1000	1525	1,25	2000	150,00

Item numbers designated with $D \leq 650$ mm are for jet caps assembled with wide pull rings [f.lyn].

Jet caps are also available for other assembly methods. See p. 6 for assembly methods.

Jet caps, galvanised

Technical data

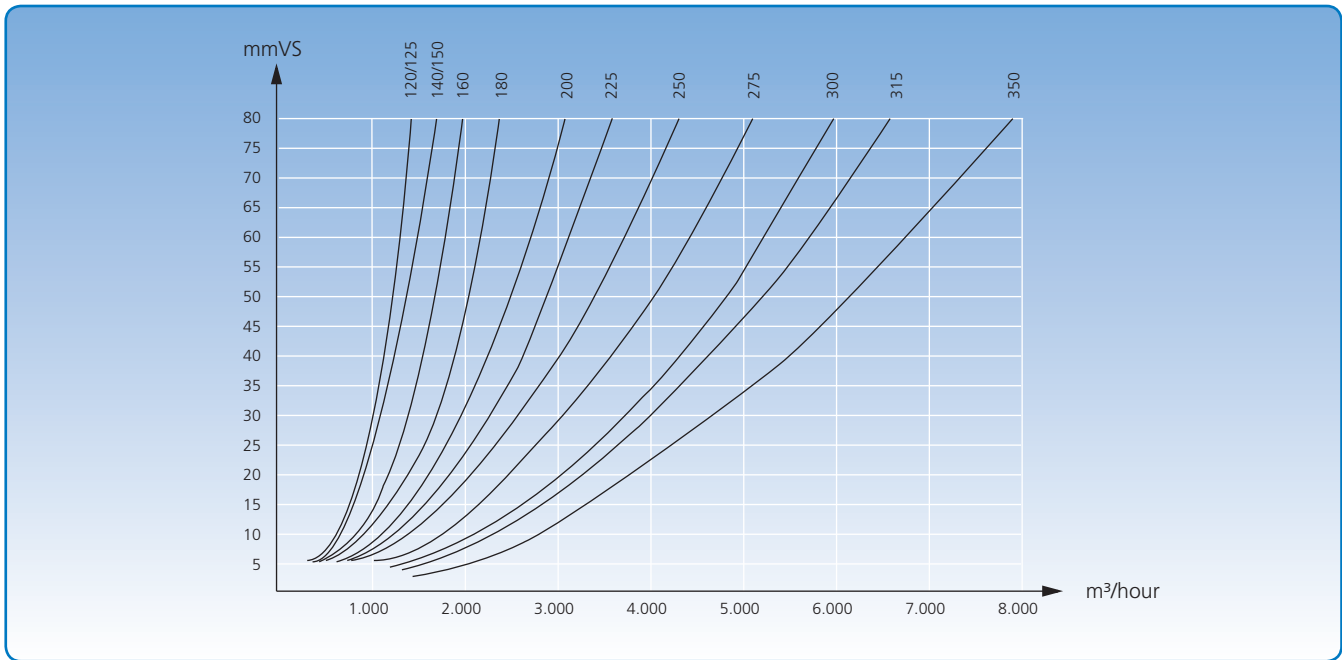

Pressure loss curves for diameter ø120 - ø350 mm.

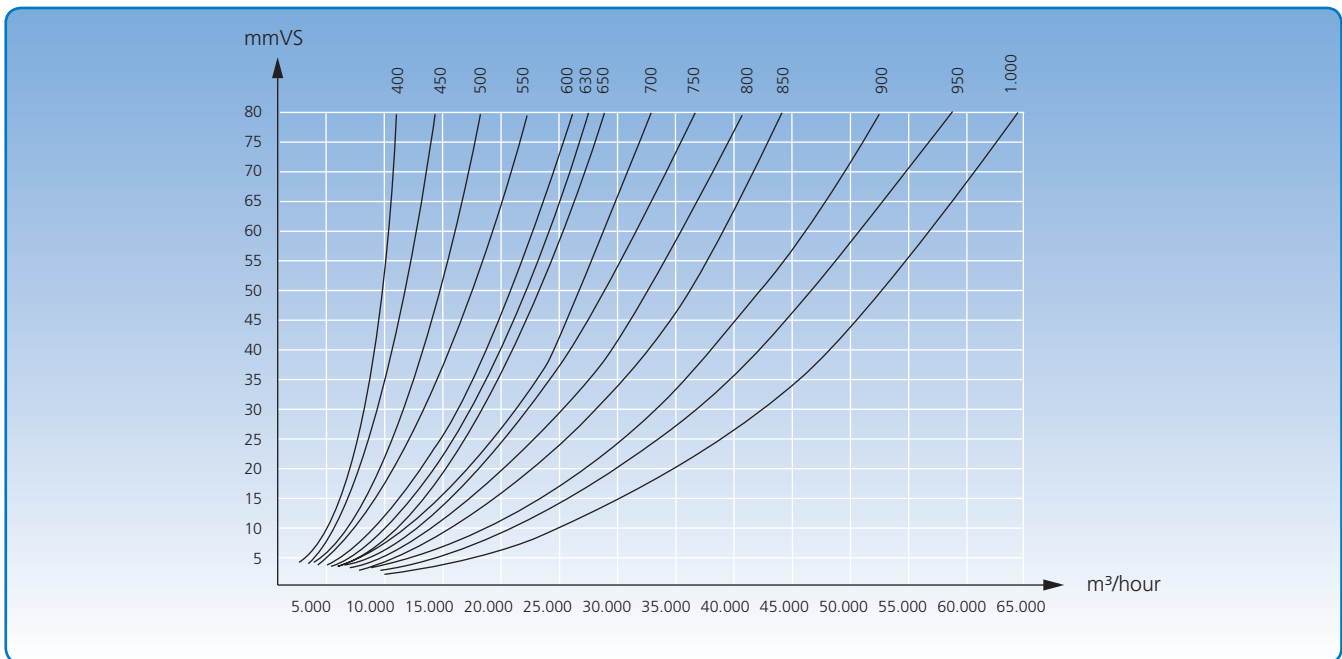

Pressure loss curves for diameter ø400 - ø1000 mm.

Rain caps, galvanised

Diameter: $\varnothing 80 - \varnothing 1250$ mm.

Supplied with the same JKF assembly methods as duct systems.

Rain caps from diameter $\varnothing 700 - \varnothing 1000$ mm are fitted with flanges as standard.

Rain caps of diameter $\varnothing 80 - \varnothing 225$ mm are supplied with a skirt and from $\varnothing 250 - \varnothing 1000$ mm with skirt and internal cone.

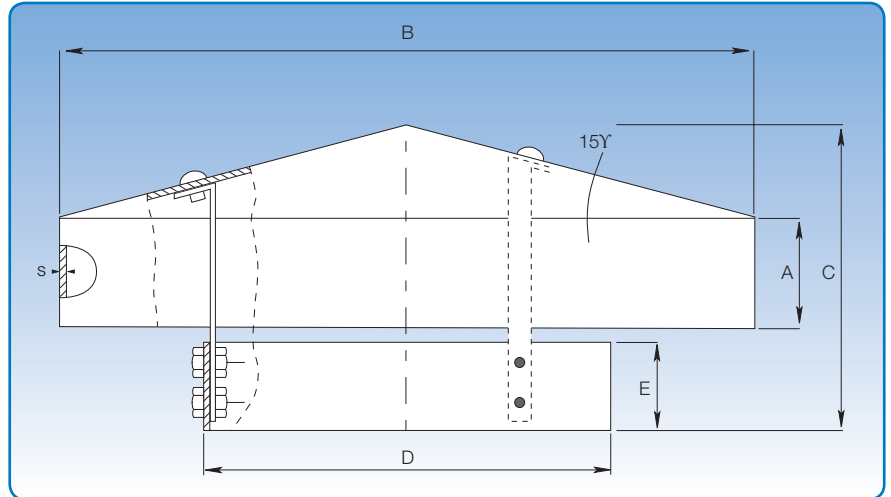

Dimensional specifications are given in the table below.

Dimensions							
Item no.	D mm	s mm	B mm	C mm	A mm	E mm	Weight kg
1970122	80	0,90	200	130	50	75	1,30
1971122	100	0,90	200	130	50	75	1,35
1972122	120	0,90	250	150	50	75	1,40
1973122	125	0,90	250	150	50	75	1,50
1974122	140	0,90	350	190	50	100	1,90
1975122	150	0,90	350	190	50	100	2,20
1976122	160	0,90	350	190	50	100	2,40
1977122	180	0,90	400	220	50	100	2,66
1978122	200	0,90	400	220	50	100	4,00
1979122	225	0,90	500	240	50	100	5,30
1980122	250	0,90	500	240	50	100	5,90
1980162	275	0,90	500	240	50	100	6,00
1981122	300	0,90	650	340	100	150	6,10
1982122	315	0,90	650	340	100	150	6,12
1983122	350	0,90	650	340	100	150	6,14
1984122	400	0,90	750	371	100	150	6,30
1985122	450	0,90	750	370	100	150	7,00
1986122	500	0,90	950	440	150	150	9,70
1987122	550	0,90	950	440	150	150	9,70
1988122	600	0,90	1050	480	150	150	12,00
1989122	630	0,90	1050	480	150	150	10,40
1990122	650	0,90	1050	480	150	150	11,00
1991122	700	0,90	1200	570	200	200	19,20
1992122	750	0,90	1200	570	200	200	20,90
1993122	800	1,25	1400	610	200	200	22,30
1994122	850	1,25	1400	610	200	200	26,90
1995122	900	1,25	1550	680	250	200	29,70
1996122	950	1,25	1550	680	250	200	31,35
1997122	1000	1,25	1700	720	250	200	34,50
1998122	1100	1,25	1850	745	250	200	38,00
1999122	1250	1,25	2000	765	250	200	43,20

The item numbers stated are for rain caps assembled using wide pull rings [f.lyn]. Rain caps are also available for other assembly methods. See p. 6 for assembly methods.

Clip bands, galvanised

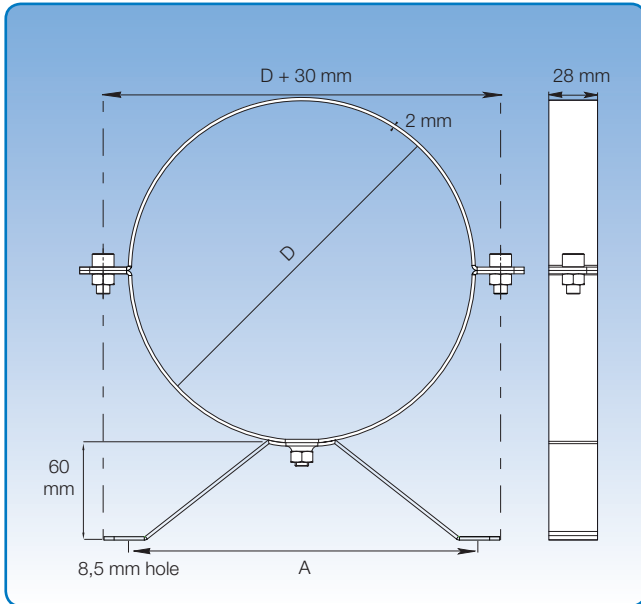

Diameter: $\varnothing 80 - \varnothing 315$ mm.

Supplied for mounting JKF duct systems. 3 different mounting principles: with legs, wall mounted and hanging.

Recommended distance between bands: 1 band to every other assembly.

They are supplied in plastic bags of 5, along with the necessary nuts and bolts.

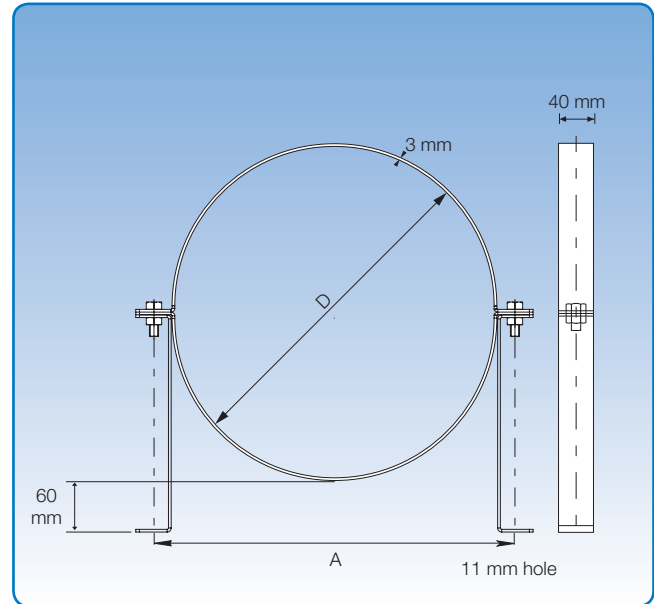

Diameter: $\varnothing 350 - \varnothing 800$ mm.

Supplied for mounting JKF duct systems. 3 different mounting principles: with legs, wall mounted and hanging.

Recommended distance between bands: 1 band to every other assembly.

s = 2 mm			
Item no. without legs	D mm	A mm	Weight kg
4670280	80	132	0,27
4671280	100	132	0,29
4672290	120	132	0,32
4673280	125	132	0,33
4674280	140	132	0,35
4675280	150	132	0,36
4676280	160	132	0,38
4677280	180	210	0,43
4678280	200	210	0,46
4679280	225	210	0,50
4680280	250	210	0,53
4688289	275	210	0,57
4681280	300	210	0,60
4682280	315	210	0,62

s = 3 mm			
Item no. without legs	D mm	A mm	Weight kg
4683280	350	399	1,66
4683290	375	424	1,71
4689280	400	679	1,83
4684290	425	474	1,91
4685280	450	499	2,01
4685290	475	524	2,08
4686280	500	549	2,27
4687280	550	599	2,33
4688280	600	649	2,42
4689280	630	679	2,51
4690280	650	699	3,64
4691280	700	749	3,88
4692280	750	799	4,09
4693280	800	849	4,31

Clip bands, primed, heavy design

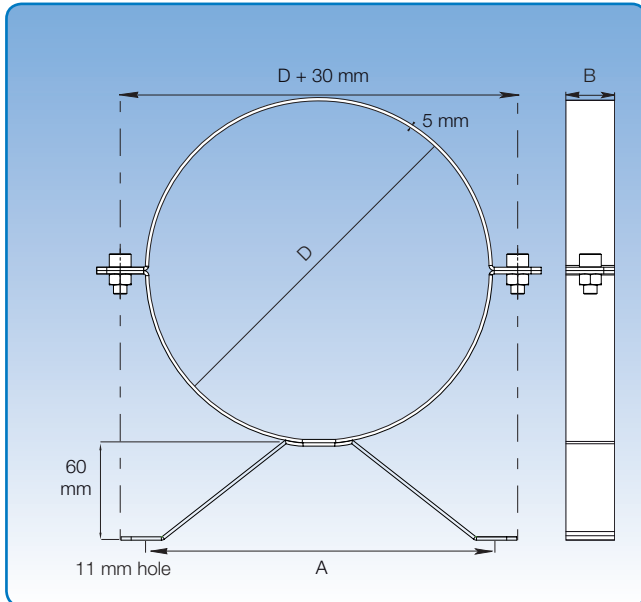

Diameter: $\varnothing 80 - \varnothing 315$ mm.

Supplied for mounting JKF duct systems. Can be used for 3 different mounting principles.

Recommended distance between bands: 1 band to every other assembly.

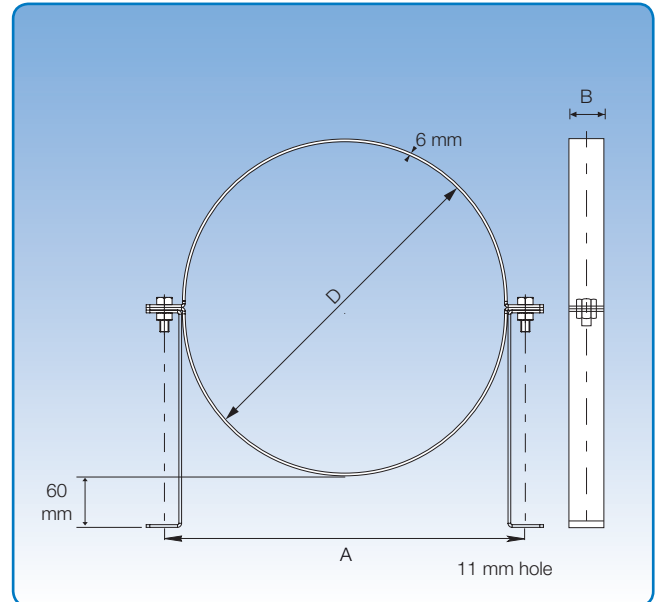

Diameter: $\varnothing 350 - \varnothing 1000$ mm.

Supplied for mounting JKF duct systems. Can be used for 3 different mounting principles.

Recommended distance between bands: 1 band to every other assembly.

s = 5 mm				
Item no.	D mm	B mm	A mm	Weight kg
4621080	80	25	132	0,58
4621100	100	25	132	0,64
4621120	120	25	132	0,70
4621125	125	25	132	0,72
4621140	140	25	132	0,77
4621150	150	25	132	0,79
4621160	160	25	132	0,82
4621180	180	25	210	0,94
4621200	200	25	210	1,00
4621225	225	25	210	1,08
4621250	250	25	210	1,16
4621275	275	25	210	1,23
4621300	300	25	210	1,31
4621315	315	25	210	1,35

s = 6 mm				
Item no.	D mm	B mm	A mm	Weight kg
4623280	350	30	401	2,60
4624280	400	30	451	2,89
4625280	450	30	501	3,18
4626280	500	30	551	3,49
4627280	550	30	601	3,77
4628280	600	30	651	4,06
4629280	630	30	681	4,21
4630280	650	30	701	4,36
4631280	700	40	761	6,33
4632280	750	40	811	6,74
4633280	800	40	861	7,11
4634280	850	40	911	7,50
4635280	900	40	961	7,89
4636280	950	40	1011	8,30
4637280	1000	40	1061	8,69

Cutting screens, galvanised

Diameter: $\varnothing 100 - \varnothing 150$ mm.

JKF's standard range includes cutting screens made of 0.90 mm galvanised sheet metal (s).

Screens supplied with mounting magnets.

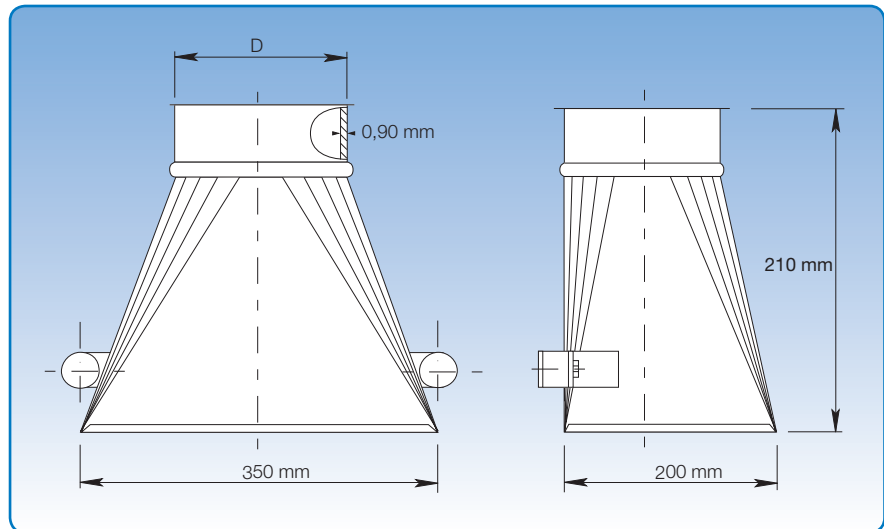

Dimensional specifications are given in the table below.

Item no.	Dimensions		Weight kg
	D mm		
4671601	100		1,50
4671602	120		1,75
4671603	125		1,89
4671604	140		2,00
4671605	150		2,25

The item numbers stated are for cutting screens assembled using rapid lock pull rings [f.lyl].

Sweep ups, galvanised

Diameter: $\varnothing 100 - \varnothing 200$ mm.

Sweep ups for suction of floor areas are made of 0.90 mm galvanised sheet metal.

Sweep ups are fitted with grill and no gate as standard. Can be supplied with both.

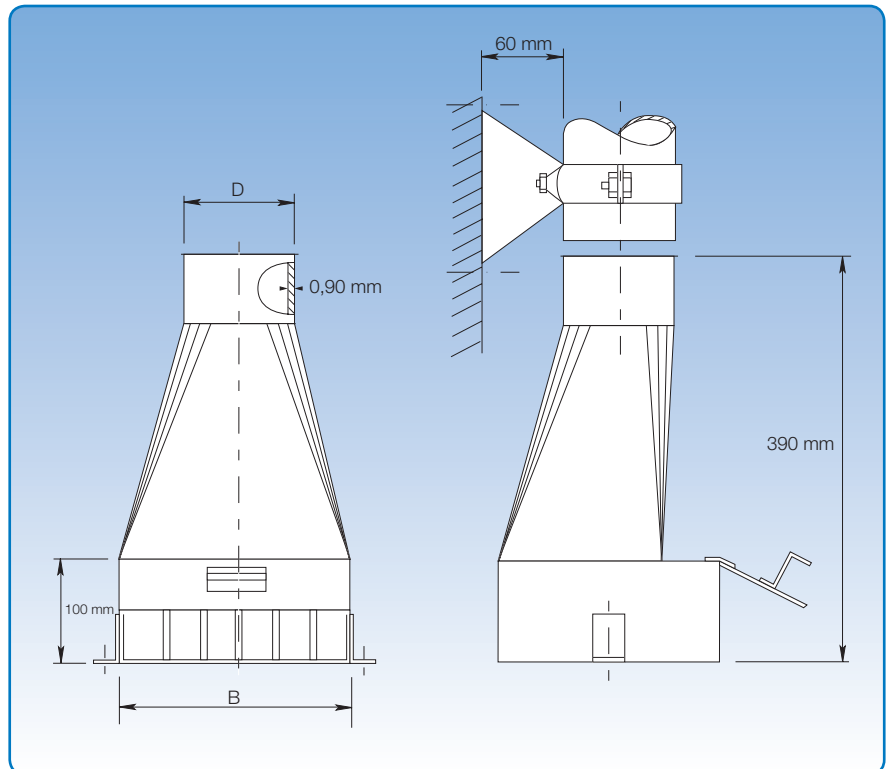

Dimensional specifications are given in the table below.

Item no.	Dimensions		Weight kg
	D mm	B mm	
4671401	100	220	3,53
4672401	120	220	3,77
4673401	125	220	3,77
4674401	140	220	3,79
4675401	150	285	3,81
4676401	160	285	3,88
4677401	180	285	4,58
4678401	200	285	4,80

The item numbers stated are for sweep ups assembled using rapid lock pull rings [f.lyn].

Sputniks, galvanised

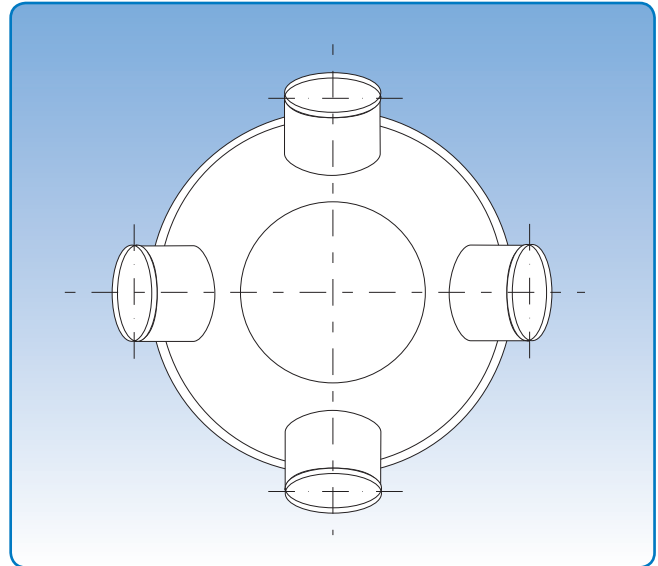
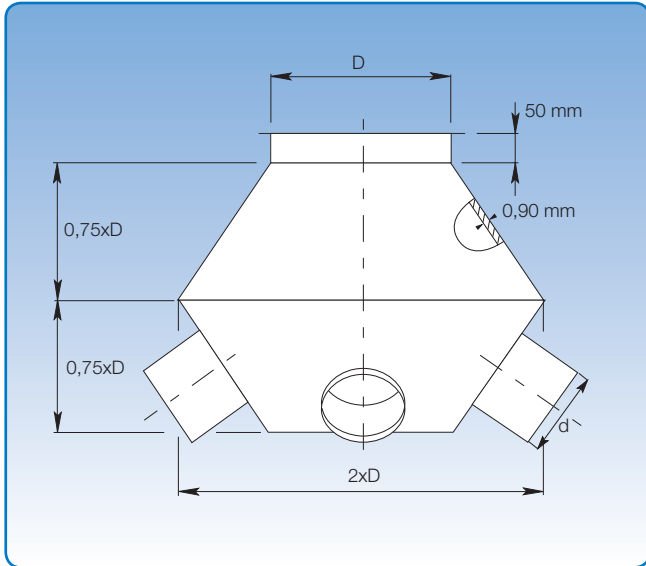

Dimensional specifications are given in the table below.

Diameter: $\varnothing 80 - \varnothing 500$ mm.

Sputniks are made of 0.90 mm galvanised sheet metal (s).

Sputniks are for use where several suction intakes are merged into a single duct.

Sputniks are available with 2 - 9 suction spigots.

State D and d and number of suction spigots plus assembly method when ordering.

Dimensions	
D mm	Weight kg
80	1,28
100	1,60
120	2,00
125	2,60
150	3,27
160	4,09
180	5,12
200	6,40
250	8,00
300	10,00
315	12,00
350	14,50
400	17,40
450	21,00
500	25,00

Purflex hoses

Diameter: $\varnothing 50$ - $\varnothing 450$ mm.

Purflex hoses are ideal for use in the chemical and petrochemical industries, for gases, cement dust, granulates, abrasive powders, shavings etc.

They are very hard-wearing and made of 100% polyurethane in a single film layer with welded-in, corrosion protected steel spiral.

Temperature range tolerance from -40°C to $+90^{\circ}\text{C}$.

Purflex hoses are only available in the length of 5 m.

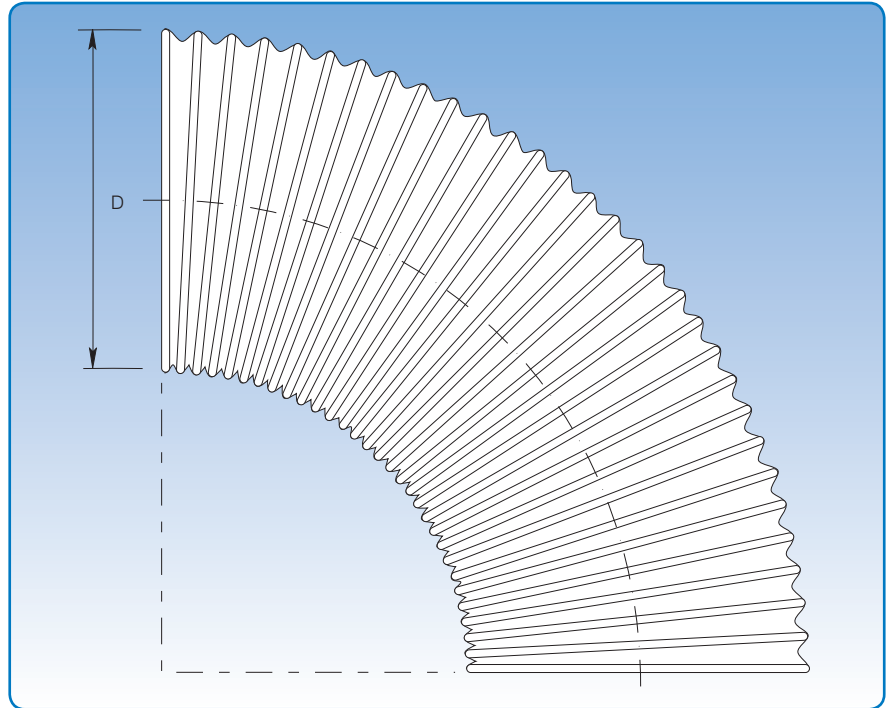

Dimensional specifications are given in the table below.

Item no.	Description	Dimensions		
		D mm	Bending radius mm	Weight kg / m
836505005	Hoses PUR 301 AS	50-51	33	0,280
836506005	Hoses PUR 301 AS	60	38	0,340
836506305	Hoses PUR 301 AS	63-65	40	0,360
836507005	Hoses PUR 301 AS	70	43	0,380
836508005	Hoses PUR 301 AS	80	48	0,440
836509005	Hoses PUR 301 AS	89-90	53	0,480
836510005	Hoses PUR 301 AS	100-102	58	0,510
836512005	Hoses PUR 301 AS	120	68	0,610
836512505	Hoses PUR 301 AS	125-127	71	0,630
836514005	Hoses PUR 301 AS	140	78	0,710
836515005	Hoses PUR 301 AS	150-152	83	0,760
836516005	Hoses PUR 301 AS	160	88	0,810
836518005	Hoses PUR 301 AS	178-180	98	0,900
836520005	Hoses PUR 301 AS	200-203	108	1,030
836522505	Hoses PUR 301 AS	225	122	1,160
836525005	Hoses PUR 301 AS	250	136	1,280
836528005	Hoses PUR 301 AS	280	149	1,430
836530005	Hoses PUR 301 AS	300	159	1,700
836531505	Hoses PUR 301 AS	315	167	1,790
836535005	Hoses PUR 301 AS	350	185	2,000
836540005	Hoses PUR 301 AS	400	210	2,260
836545005	Hoses PUR 301 AS	450	235	2,520
8365125051	Hoses PUR 330 AS	125-127	71	0,820
8365140051	Hoses PUR 330 AS	140	78	0,920
8365160051	Hoses PUR 330 AS	160	88	1,040
8365200051	Hoses PUR 330 AS	200-203	108	1,540

Sanding tables, galvanised

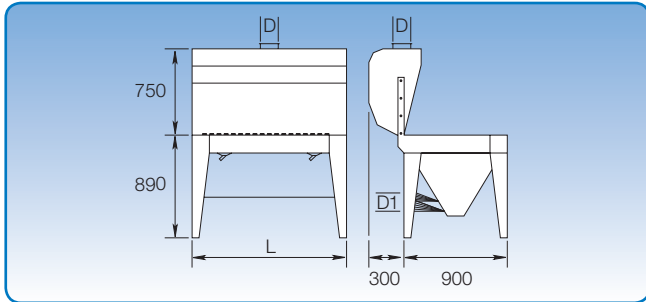

Sanding tables are designed to give the operator optimum working conditions. This applies to ergonomic and environmental conditions.

A special "Coanda" effect is used, which keeps the operator's respiratory system free of airborne dust.

Air volume can be adjusted in models with a louvre gate in the top.

Sanding tables are made of galvanised sheet metal.

2 different sizes are available as standard.

Dimension 900 mm.

Dimension 1350 mm.

Leg height is not adjustable. Fixed legs can be ordered for a specified table height.

Dimension 900:

Supplied as standard with no louvre gate but with upper screen.

At an additional price:

Special model with louvre gate and upper screen.

Special model with no louvre gate and upper screen.

Special model with louvre gate and no upper screen.

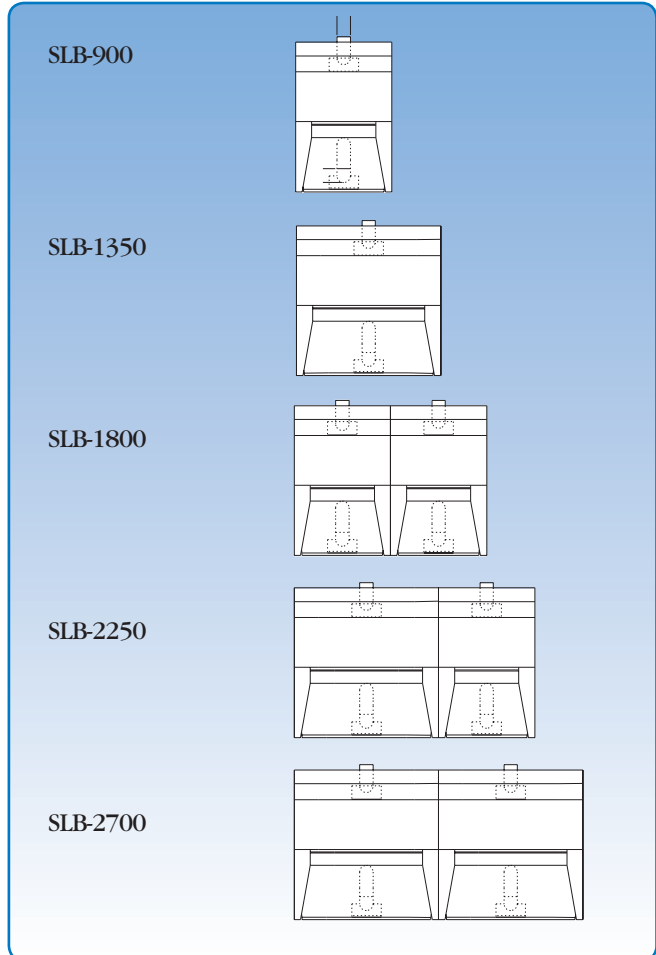

Dimensional specifications are given in the table below.

Dimension 1350:

Supplied as standard with no louvre gate but with upper screen.

At an additional price:

Special model with louvre gate and upper screen.

Special model with no louvre gate and upper screen.

Special model with louvre gate and no upper screen.

Type	Dimensions			Primary suction m ³ / h	Suction below table m ³ / h	Weight kg
	L mm	D mm	D1 mm			
SLB-900	900	125	125	1200	1200	79
SLB-1350	1350	160	150	1800	1200	96
SLB-1800	1800	2 x 125	2 x 125	2400	2400	160
SLB-2250	2250	160 and 125	150 and 125	3000	2400	176
SLB-2700	2700	2 x 160	2 x 150	3600	2400	195

Appendix 1

Conclusions from test report

JKF's duct system has been tested to establish its strength. System stability has been established by performing an internal water pressure test. The test was performed by JKF under the auspices of the Danish Technological Institute (material test).

Resistance up to overpressure of 9 bar

Ducts and assemblies 2 and 3 mm thickness with welded flanges and flat gaskets up to a diameter of 600 mm.

Ducts up to L = 2000 mm

Galvanised ducts and assemblies 0.9 mm thickness with loose flanges and flat gaskets up to a diameter of 400 mm.

Ducts up to L = 2000 mm

Resistance up to overpressure of 6 bar

Ducts and assemblies 2 and 3 mm thickness with welded flanges and flat gaskets of diameter 600 mm up to 800 mm.

Ducts up to L = 2000 mm

Resistance up to overpressure of 3 bar

Galvanised ducts and assemblies 0.75 mm thickness with 1 pull ring and U-shaped gasket or rapid lock pull rings with U-shaped gasket up to a diameter of 200 mm.

Ducts up to L = 2000 mm

Bends 30° up to 90°

Resistance up to overpressure of 1.5 bar

Galvanised ducts and assemblies 0.9 mm thickness with 1 pull ring and U-shaped gasket or rapid lock pull rings with U-shaped gasket up to a diameter of 400 mm.

Ducts up to L = 2000 mm

To ensure assemblies are tight, screws have to be tightened correctly (torque setting 25 Nm). Using a loose flange assembly, M10 (M12) screws have to be tightened to 40 Nm (60 Nm). The entire duct system must be checked regularly for wear and corrosion to ensure its integrity. Worn components must be replaced.

Finn Dombernowsky

Civil Engineer



THE WAY TO CLEAN AIR



JKF Industri A/S
Rørsangervej 5, Als
9560 Hadsund
Denmark
Tel: +45 98581211
Fax: +45 98581177
info@jkf.dk
www.jkf.dk

JKF Polska Sp. z o.o.,
Berzyna 81,
64-200 Wolsztyn
Poland
Tel: +48 683470700
Fax: +48 683845338
info@jkfpolska.pl
www.jkfpolska.pl

JKF Industri Sdn. Bhd.
Lot 8521, Jalan Persiaran Galla,
Galla Industrial Park, 70200 Seremban
N.S.D.K., Malaysia
Tel: +60 67649861
Fax: +60 67649863
info@jkf.com.my
www.jkf.com.my