

Valid from March 2019

# PRODUCT CATALOGUE

SYSTEMS FOR LOCAL EXHAUST VENTILATION - FANS- ATEX - AUTOMATICS  
HIGH VACUUM - EXTRACTION ARMS - FILTERS - WELDING BOOTHS - HOSES



CLEAN AIR - PURE SENSE

[www.geovent.com](http://www.geovent.com)



# **GEOVENT**

## Clean air – Pure sense

GEOVENT A/S is a dynamic company specialising in development and production of components and systems for advanced industrial ventilation. Since 1968 we have earned our reputation as being pioneers in this field.

GEOVENT manufactures local exhaust ventilation and process extraction for industry, defence, power plants, technical schools, laboratories, off-shore, fire- and emergency departments and auto repair shops.

All our products live up to statutory requirements for effective and environmentally safe extraction.

We focus on our customers' demands for functional and effective ventilation.

GEOVENT offers fast delivery of both smaller and larger complete ventilation solutions. To be able to do this, we keep stock of a wide ranges of pre produced components and have a versatile and modern factory.

We take pride in a dedicated staff of competent and experienced employees who know it is important to satisfy our customers and to meet the deadline. Our products are sold via professional distributors in many countries.

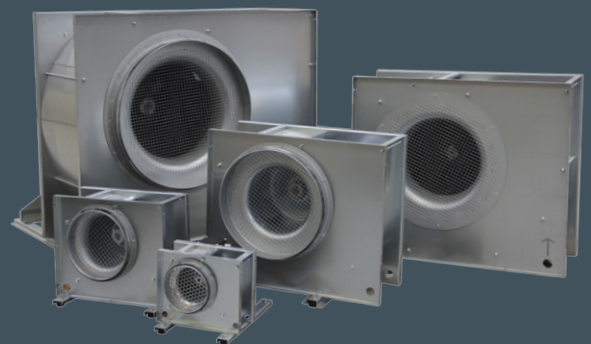

Member of

Association for good Indoor Climate

# Table of Content

<b>Exhaust fumes</b>		<b>High Vacuum</b>	
Hose reels	4	HVU Lite / HVU	92
Channel Duct	10	HVU-IT	93
Spring Balancer	13	HVU Solo	95
Garland system	14	Accessories for High Vacuum	97
Extraction for emergency vehicles	15	HVU Duct and fittings	98
Nozzles	16		
Extraction Hood	20		
<b>Extraction Arms</b>		<b>ATEX</b>	
WING arm	32	ATEX Fan	103
COMPACT arm	33	ATEX Extraction Arms	106
ASA 3 and 4 arm	34	ATEX Filters and High Vacuum	107
ESA arm	36		
Miniarm	37		
FLEXI arm	39		
PERMA arm	41		
<b>Filters</b>		<b>Workplace design</b>	
Oil Mist Filters	52	Welding Booths and welding curtain	110
Filters for dust, welding and more	53	Grinding	112
Filter media	54	Welding table	112
Geofilter GFB2 Tower	58	Smoking Cabin	112
		Spray Booth	112
<b>Fans</b>		<b>Air Handling Units - GRTU</b>	
LSFG/MSFG	62	GRTU roof top unit	116
LEF/MEF 250-630	64	GRTU accessories	116
LEF 800-1000	68		
Sound boxes for fans	70		
Accessories for fans	71		
MSQ and MHF fans	73		
Plastic Fans	74		
Portable Fans	76		
EC-Fans	78		
<b>Automatics</b>		<b>Hoses and accessories</b>	
Automatics for fans	87	Hoses	117
Frequency Inverters	88	Accessories	120
		Ducts and Bends	121
		<b>Sales- and delivery terms</b>	
		Sales and delivery terms	124
		Guide for point extraction	125

# HOSE REEL GTE/GTS



Over the years Geovent has built a considerable know-how in the field of repair shop health and safety. Shown in the photos are results of complete extraction installations in auto repair shops. Among other things Geovent has supplied hose reels for exhaust extraction, general ventilation and welding extraction. The result is a safer working environment for the mechanics and leaves the customers with an impression of a professional and well run repair shop.







The hose reels are used for exhaust extraction in garages or repair shops. The hose reel is always available and there are no hoses lying on the floor.

Geovent type GTS (spring) or GTE (electrical), is a series of hose reels based on a joint platform, which means great quality and quick delivery time, and furthermore, makes it easy to upgrade from spring to electrical – should the need occur.

The hose reels come as standard in widths of 1.000 mm (750 and 1.400mm upon request), and fits  $\varnothing 80$ ,  $\varnothing 100$ ,  $\varnothing 125$ ,  $\varnothing 150$  and  $\varnothing 200$  mm hose, in lengths up to 10m (15m upon request).

Hose reel GTE is supplied with a strong motor and radio remote control for improved operating comfort.

The GTS, is supplied with a steel spring. The spring in the hose reel GTS works the same way as a blind (pull down, and wait for the lock to settle).

The hose reel is solidly built, with a construction of galvanized and powder coated parts, to ensure long time permanence. A spherical ball bearing assures trouble-free and easy operation.



## Hose reel GTE



Electric hose reel with wireless remote control. ø160 mm nipple and 1x 230V. With hose but without nozzle.

Art. No.	Description
----------	-------------

04-714	Hose reel GTE-05-080
04-715	Hose reel GTE-07-080
04-716	Hose reel GTE-10-080
04-717	Hose reel GTE-05-100
04-718	Hose reel GTE-07-100
04-719	Hose reel GTE-10-100
04-720	Hose reel GTE-05-125
04-721	Hose reel GTE-07-125
04-722	Hose reel GTE-10-125
04-723	Hose reel GTE-05-150
04-724	Hose reel GTE-07-150
04-725	Hose reel GTE-10-150
04-730	Hose reel GTE-1400-15-100
04-731	Hose reel GTE-1400-15-125
04-732	Hose reel GTE-1400-15-150
04-735	Hose reel GTE-200-1400-05-200
04-736	Hose reel GTE-200-1400-07-200
04-737	Hose reel GTE-200-1400-10-200
04-738	Hose reel GTE-200-1400-15-200



Electric hose reel GTE-200 with wireless remote control. ø200 mm nipple. With hose, but without nozzle.

## Hose reel GTS



Spring operated hose reel with click-lock. ø160 mm nipple connection, with hose, but without nozzle.

Art. No.	Description
----------	-------------

04-700	Hose reel GTS-05-080
04-701	Hose reel GTS-07-080
04-702	Hose reel GTS-10-080
04-703	Hose reel GTS-05-100
04-704	Hose reel GTS-07-100
04-705	Hose reel GTS-10-100
04-706	Hose reel GTS-05-125
04-707	Hose reel GTS-07-125
04-708	Hose reel GTS-10-125
04-709	Hose reel GTS-05-150
04-710	Hose reel GTS-07-150
04-711	Hose reel GTS-10-150

Hose Reel GTS-10-150

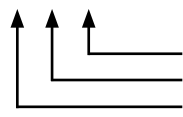

Legend

Hose diameter

Hose length

Type-description

By default all GTS hose reel have hose stop included.  
For other combinations please enquire.

## Accessories for hose reel type GTE and GTS



Art. No.	Description
04-293	Switch for automatic start/stop of fan or damper activation.

## Accessories for hose reel



Art. No.	Description
04-680	Remote control for hose reel type GTE - 1 channel (for one reel)



Remote controls for old hose reels	
04-630	Remote control 25-27 MHz. Before 2001
04-621	Remote control 434 MHz. 2001-2005
04-627	Remote control 433,42 MHz. 2005-2007
04-624	Remote control 2007
04-631	Remote control 433,92 MHz. 2008 and forward

Fan MSQ for direct mounting on the side of the hose reel.  
See Fans section of this catalogue

## Pressure drop - Hose Reel

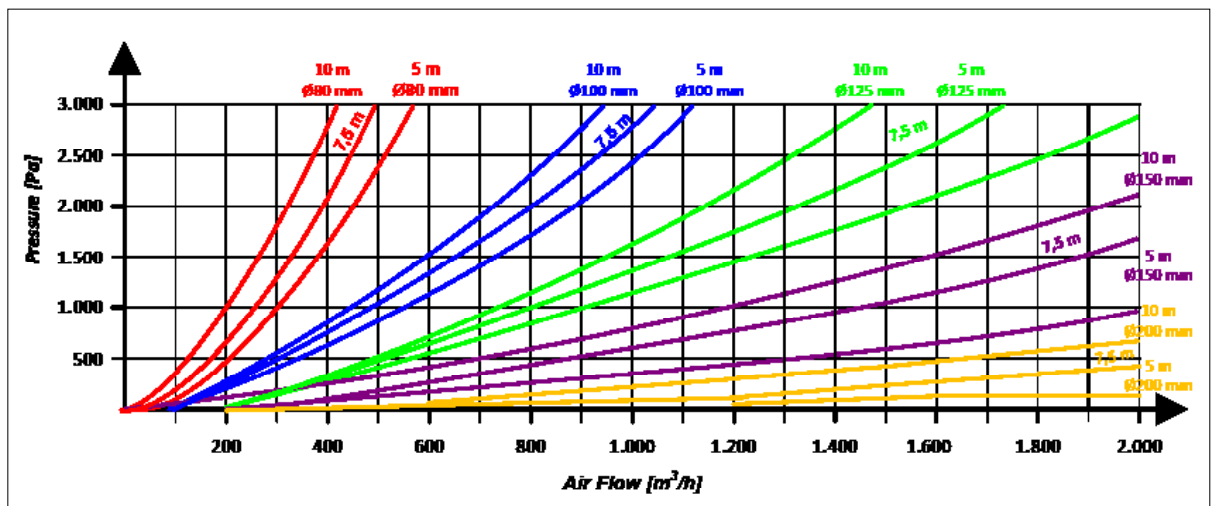

## Dimensions - Hose reel

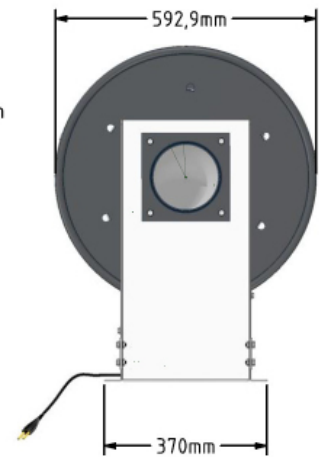
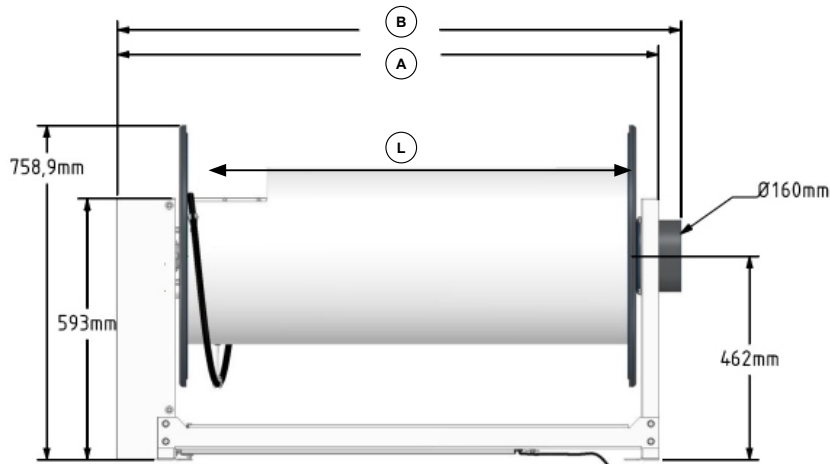

Hose reel  
Ø200 mm

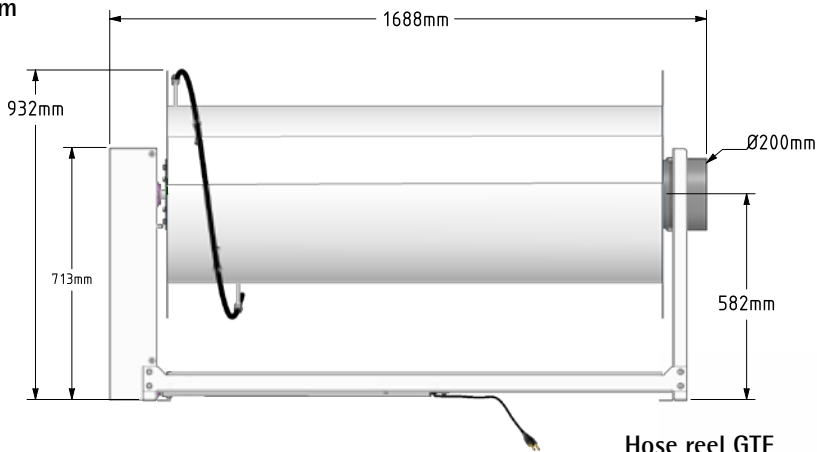

Hose reel GTE

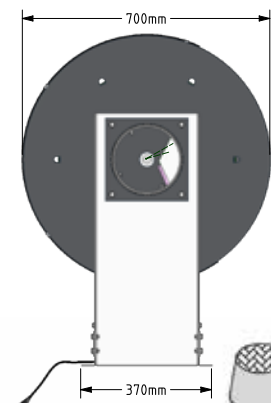

Hose reel ø80, ø100, ø125, ø150 mm

Hose	L	A	B
Hose ø 750 mm	750 mm	980 mm	1031 mm
Hose ø 1000 mm	1000 mm	1230 mm	1281 mm
Hose ø 1400 mm	1400 mm	1630 mm	1681 mm

- A: Outlet with jet hood
- B: Outlet flange
- C: Fan MSFG
- D: Wall mounting bracket
- E: Start/stop control LWS
- F: Fast action motor Damper ø160 mm
- G: Hose reel GTE
- H: Radio remote control
- I: Rubber nozzle

## Installation examples - hose reels

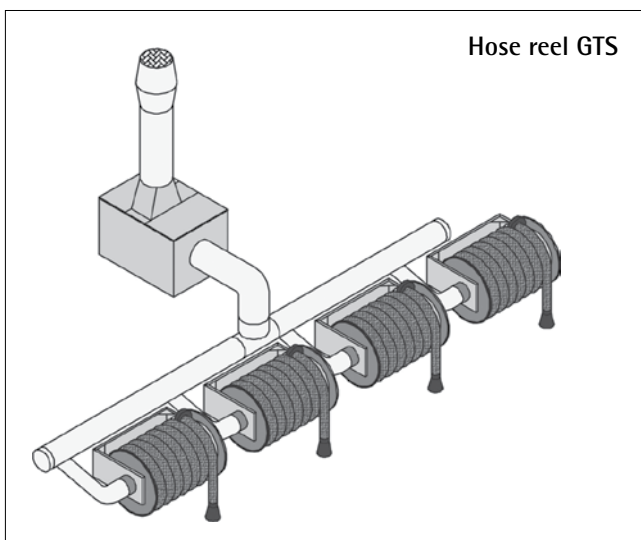

Optional:  
Start/stop switch for fan  
and open/close motor  
damper.

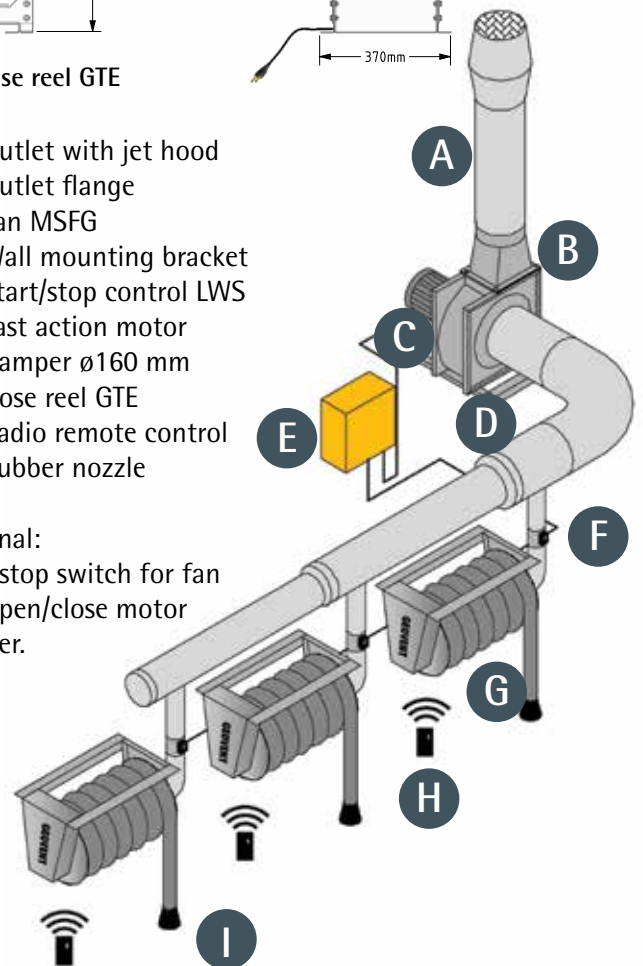



# EXTRACTION HOODS



Extraction Hood



At DSB (The Danish National Railways) they had a challenge with exhaust gas from their diesel locomotives. The hoods, they were using were not working properly, which resulted in exhaust gas polluting the air in the garage. The airflow was too low and the hood was not designed to do the job properly. Geovent, along with the consulting engineer, the installation company and DSB, ended up with a specialized product for removing exhaust gas fumes from locomotives. The hood is constructed of galv. sheet metal, and electrically controlled, with a motorized telescopic function, which makes operation easy. The hood can be controlled by a switch, or central BMS, for automatic positioning, when the train is at the correct location. It means, when the train drives into the maintenance garage, the hoods are automatically lowered to a position right above the exhaust pipe of the train and all gas is extracted effectively. When the staff is done servicing the train, the hood automatically winds up below the roof and the train can leave the garage.



Motor: 3x400V 50Hz

Standard supplied with out control panel, but can be supplied upon request.

Recommended Airflow: App. 3.000 m<sup>3</sup>/h

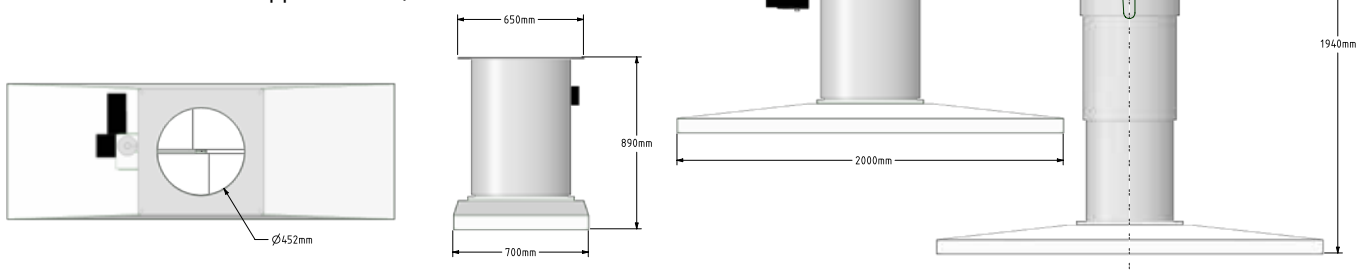

Dimensions Extraction hood

# CHANNEL DUCT



The channel duct is a versatile system, suitable for numerous applications, from exhaust gas extraction to weld fumes, it is the ideal choice, when a flexible and efficient extraction system is required to cover a large working area.

The channel duct system can be combined with extraction arms, hose reels for even wider range, or it can be mounted on a wall or ground column, which can make it 360° pivotable.

Recommended air flow:  
Standard trolley, up to 1.000 m<sup>3</sup>/h per trolley.  
Up to 2.000 m<sup>3</sup>/h with 2000M trolley.





Photo: Sergeant Tina G. Anker, Jydske Dragonregiment (INFOSEK/GSE).

For the operator, the channel duct system ensures flexibility within a large working area. The channel duct is suitable for medium and large garages/shops, where several working bays may share one or more trolleys.

**Easy operation:**

The hose trolley is equipped with 6 smoothly rolling nylon wheels, ensuring easy movement of the trolley. The irritation of having heavy, rolled-out hoses on the floor is avoided – simply push the trolley to work area.

**Mounting friendly**

We have put great focus on making our channel duct system as mounting friendly as possible. It is possible to install the channel duct with a minimum use of time and therefore save on the installation expenses.

We naturally offer our guidance and know-how.

**Accessories:**

Besides standard equipment, there is a large range of extra equipment for the channel duct:

Wireless on/off system for the fan (radio transmitted).

Wide range of spring balancers.

Hoses and nozzles for almost all tasks.

Motorized, forward and return movement of the trolley.

Compressed air nozzle for automatic uncoupling from the exhaust pipe.

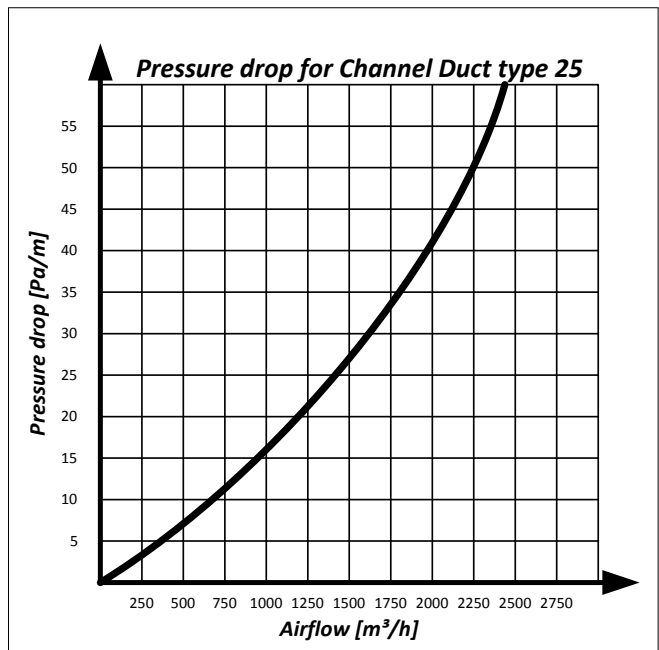
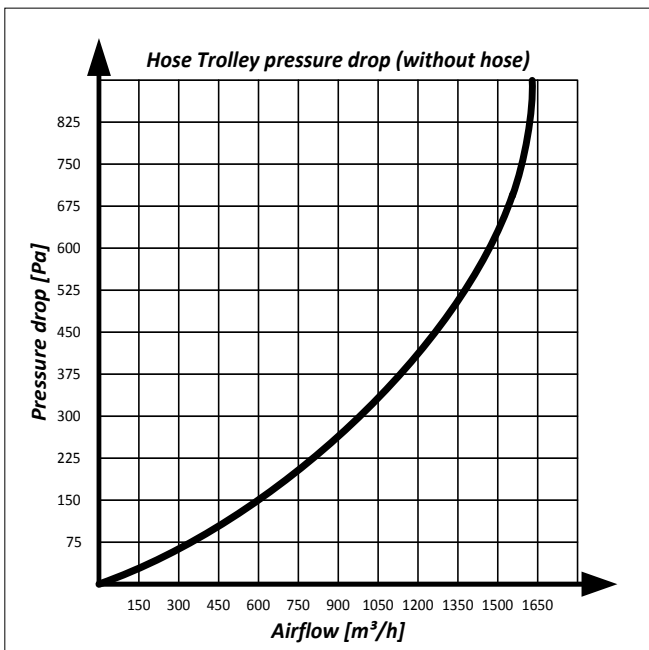
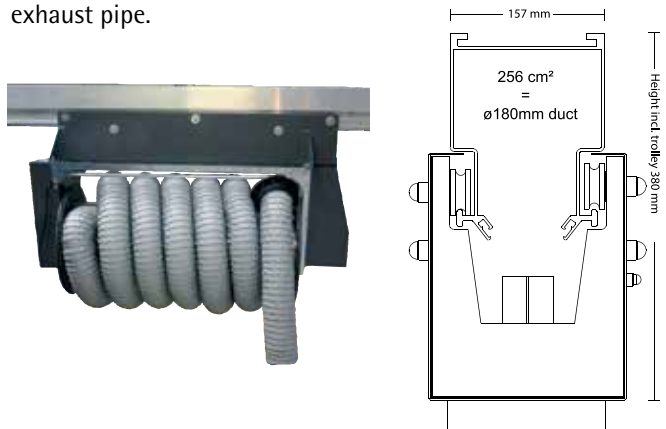



## Channel duct



Art. No.	Description
07-400	Channel duct type 25 extruded aluminium with rubber lips. Lengths of 3 and 6 meter. Height: 291mm. Width: 156mm. Channel = 256 cm <sup>2</sup> = ø180 duct. 9 kg/m. Improved profile and lips
07-400A	Reinforcement for channel duct. Should be used when the pressure exceeds 1.600 Pa in the channel duct and should be placed for every 2 meters.
07-401	Channel connection for connecting 2 lengths of channel duct. Galvanized steel - 0,25 m
07-401A	Channel connection for connecting 2 lengths of channel duct. Galvanized steel - 1 m
07-402	Assembly kit, for assembly of the channel duct. (1 set per length of channel duct.)
07-477	End stop for trolley
07-478	Spring end stop for trolley
07-403	End cover for type 25 galvanized steel
07-406	End reduction nipple ø250 mm. From the end of the channel duct to round spiro duct
56-064	Reduction galvanized, MF ø250 /NP ø160
56-065	Reduction galvanized, MF ø250 /NP ø200
07-408	Top mounted outlet, NP ø160 mm. From the top of the channel duct to round spiro duct
07-409	Top mounted outlet, NP ø200 mm. From the top of the channel duct to round spiro duct
07-410	Top mounted outlet, NP ø250 mm. From the top of the channel duct to round spiro duct
07-411	Trolley type 25, powder coated steel. Complete with 6 smooth-running nylon wheels. Ø160 mm NP connection. For air flows up to 1.200m <sup>3</sup> /h.
07-450	Trolley 27 DX powder coated steel. Complete with smooth-running ball bearing wheels and ø160 mm NP connection. Trolley with minimum friction for effortless positioning.
07-430	Trolley 2000M. 8 wheels and ø250 mm NP (L=1.000mm, W=200mm, H=289mm). For air flows up to 2.000m <sup>3</sup> /h.
07-461	Trolley for hose heel GTE/GTS. Hose reel not included.
56-042	Reduction MF160/NP80
56-043	Reduction MF160/NP100
56-044	Reduction MF160/NP125
56-045	Reduction MF160/NP150
04-460	Adapter for mounting WING/COMPACT arm on trolley 25 - ø160 mm



## Suspension of channel duct – bracket for every 2 – 4 meter channel duct

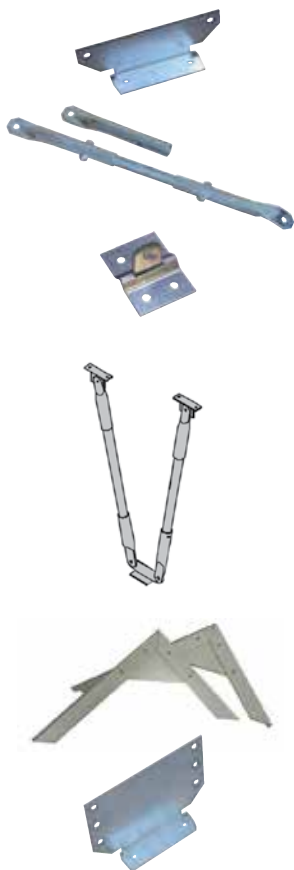

Art. No.	Description
07-656	Suspension bracket type 60 galvanized steel.
07-424	Spacer tube for suspension bracket 3/8" galv. per meter
07-422	Set with 2 coupler brackets for spacer pipes. 2 sets required for each point of fixation.
07-662	Ceiling bracket with tilt function
Suspension kit for channel duct - Content: Suspension bracket type 60 (07-656), spacer tube (07-424), coupler brackets (07-422) and ceiling bracket (07-662) 1 kit required for each point of fixation.	
07-620	1 meter suspension
07-621	2 meter suspension
07-622	3 meter suspension
07-150	Wall bracket for wall mounting. 500x370 (set of 2)
07-151	Wall bracket for wall mounting. 550x400 (set of 2)
07-152	Wall bracket for wall mounting. 600x440 (set of 2)
07-153	Wall bracket for wall mounting. 650x475 (set of 2)
07-655	Suspension bracket type 160 galvanized

## Automatics for channel duct



Art. No.	Description
07-490	Return system for channel duct. Trolley is returned to initial position with the help of small motor controlled by PLC, frequency inverter and sensor
Wireless start/stop automatics. Transmitter can be connected to start/stop switch on the hose reel or channel duct. Receiver connects to control board LWS for example.	
13-241	Wireless transmitter - end function - 9V
13-240	Wireless receiver - end function - 220V
07-100	Wire switch LWS for start/stop of fan when balancer is extended. Max. 1x250V 5A. Factory mounted on balancer of choice.
07-102	Cable festoon 2x0,75 mm <sup>2</sup> for wire switch. L=6m
07-103	Cable festoon 2x0,75 mm <sup>2</sup> for wire switch. L=12m
07-104	Cable festoon 2x0,75 mm <sup>2</sup> for wire switch. L=18m
07-106	Cable festoon 2x0,75 mm <sup>2</sup> for wire switch. L=24m

## Channel duct mounted on extension arm or floor column

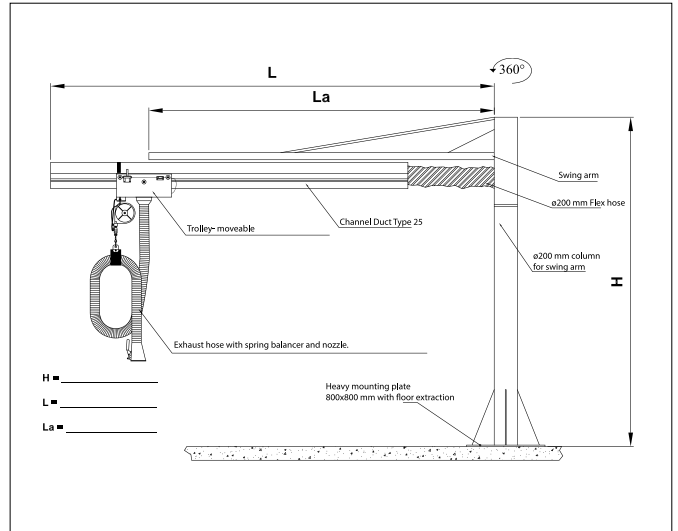
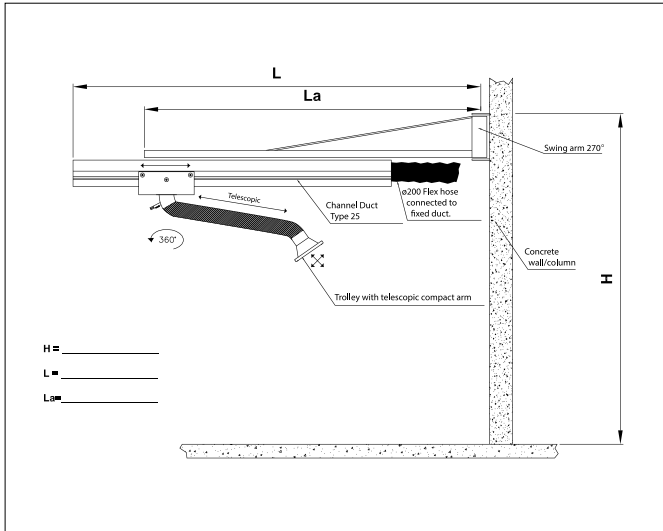

Art. No.	Description	Art. No.	Description
07-730	180° extension arm 6m for wall mounted channel duct. La = 5m Note: channel duct not included.	07-750	360° extension arm 6m with floor column H=7,5 m for channel duct, La=5m, L=6m Custom fitting available upon request. Note: channel duct not included.

## Hose suspension parts / Disconnection systems



### Art. No. Description

07-712	Multi hose suspension LWS with balancer bracket. Suitable for hose dimension $\varnothing 76 - 152$ mm
--------	---



07-716	Multi hose suspension $\varnothing 76-152$ mm
07-716A	Multi hose suspension $\varnothing 203$ mm



06-600	Safety coupling $\varnothing 100$ mm - separates the hose in two if pulling too hard
06-601	Safety coupling $\varnothing 125$ mm - separates the hose in two if pulling too hard
06-602	Safety coupling $\varnothing 150$ mm - separates the hose in two if pulling too hard



07-107	Automatic detachment system with compressed air for garland/channel duct, including mounting brackets and $\varnothing 10$ mm push-in fittings. Including end stop for activating the release valve. When the trolley reaches the end, it will release the pressure in the inflatable-nozzle.
07-120	As above, but with switch for the inflatable nozzle - with hand pump
07-770	Complete electromagnetic detachment system with control, car nozzle, electromagnet and high temperature hose

## Spring balancer



Art. No.	Description	Lock	[m]	[kg]
Aluminium spring balancer with steel wire. Progressive* pulling force. Weight: 2 - 4 kg				
07-220	DT-9336	No	2,5	2,0 - 4,0
07-221	DT-9337	No	2,5	4,0 - 6,0
07-221A	DT-9347D	Yes/No	4,5	4,0 - 6,0
07-223	DT-9338	No	2,5	6,0 - 8,0
07-223A	DT-9348D	Yes/No	4,5	6,0 - 8,0
07-224	DT-9339	No	2,5	8,0 - 10,0
07-224A	DT-9349D	Yes/No	4,5	8,0 - 10,0
07-225	DT-9340	No	2,5	10,0-14,0
07-225B	DT-9350D	Yes/No	4,5	10,0-14,0
07-225A	DT-9346	Yes	2,5	2,0 - 4,0
07-226	DT-9347	Yes	2,5	4,0 - 6,0
07-227	DT-9348D	Yes	2,5	6,0 - 8,0
07-228	DT-9349D	Yes	2,5	8,0 - 10,0
07-229	DT-9350	Yes	2,5	10,0-14,0
07-230	DT-9362	No	2	15,0-20,0
07-231	DT-9363	No	2	20,0-25,0

\* When released, the hose will accelerate all the way up

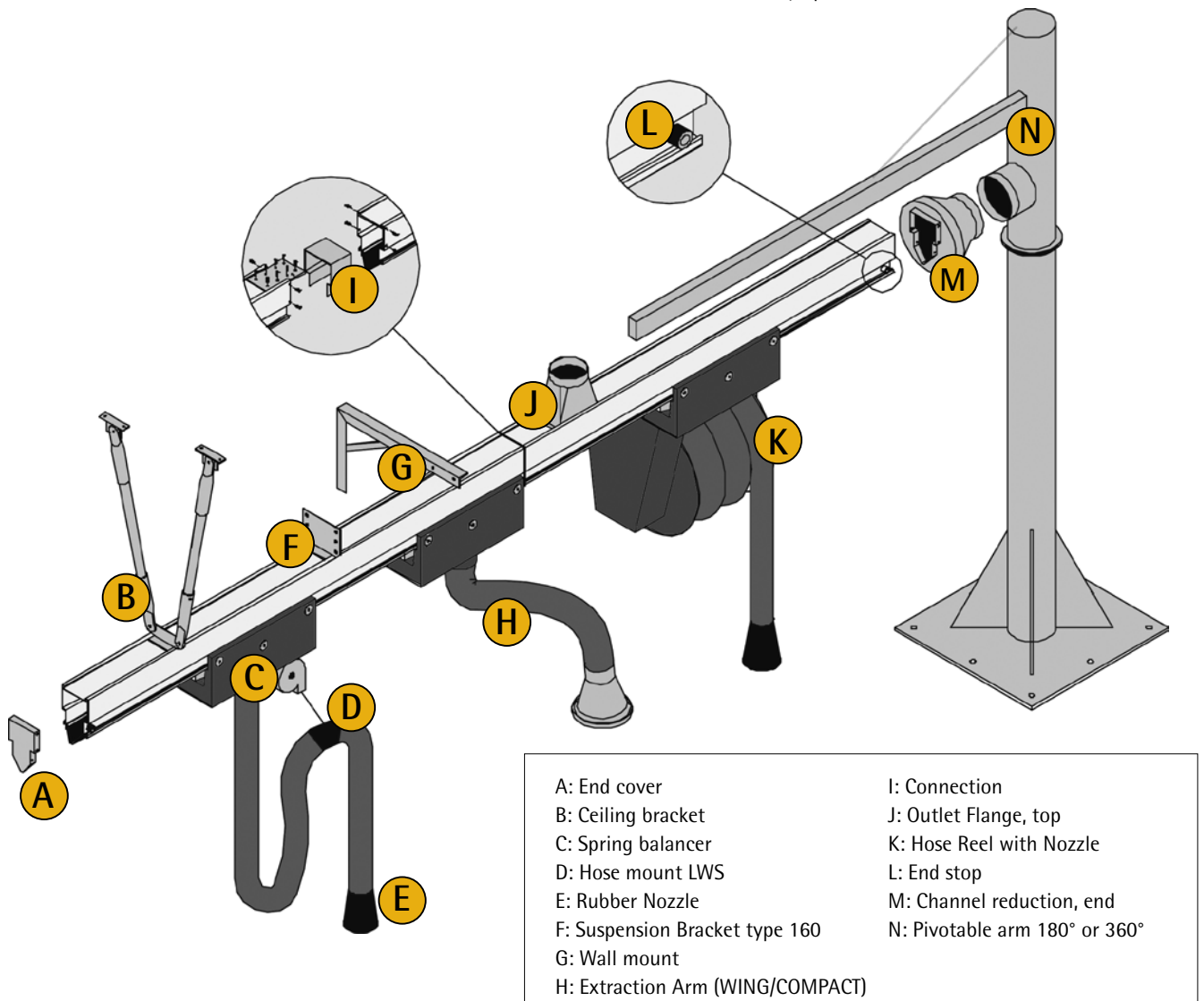

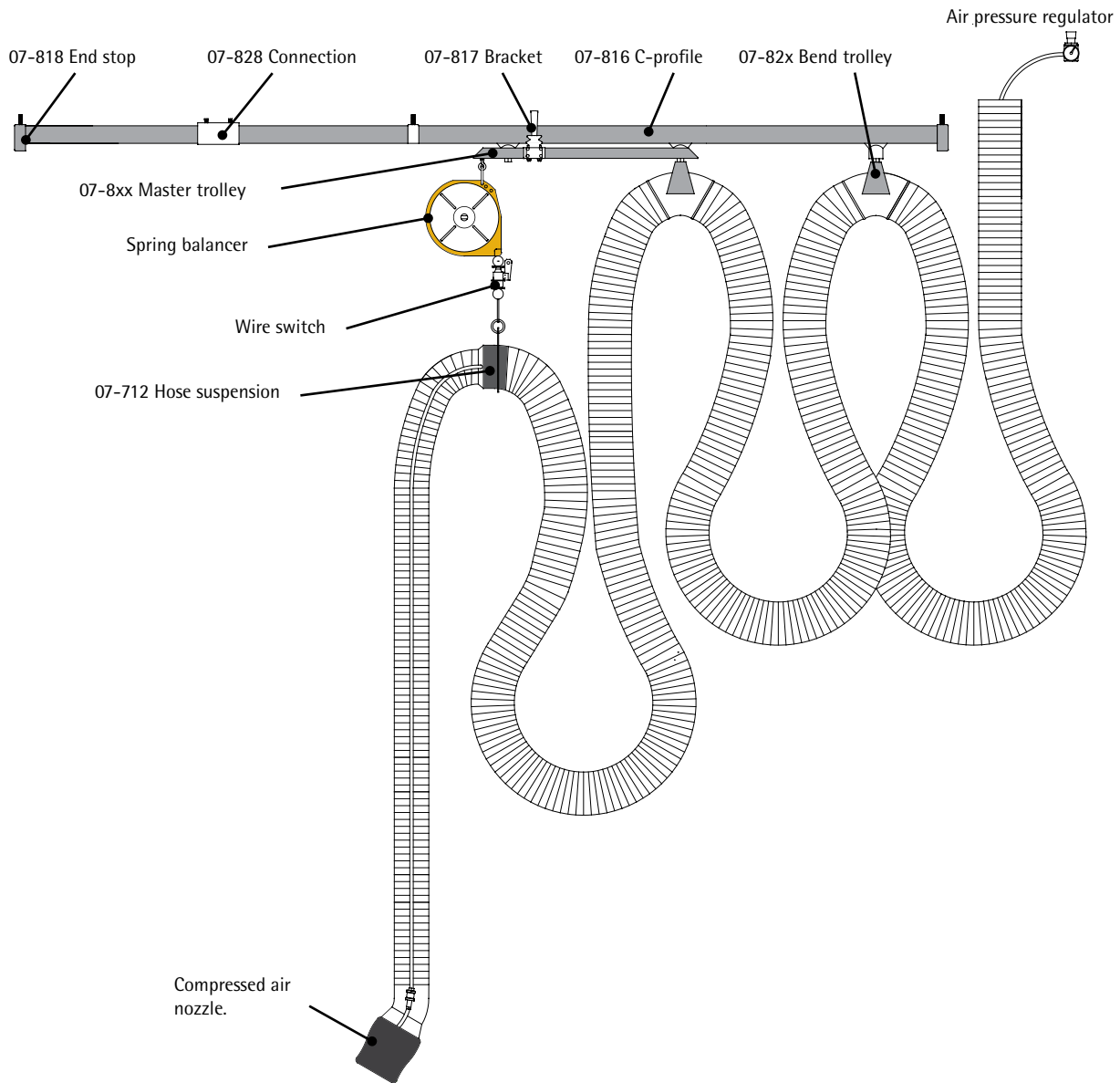

All master and bend trolleys are fitted with smooth running and low noise rubber clad steel wheels with ball bearings.

Art. No.	Description
07-821	Master trolley $\varnothing$ 100 mm – with bend 360° pivotable
07-820	Master trolley $\varnothing$ 125 mm – with bend 360° pivotable
07-819	Master trolley $\varnothing$ 150 mm – with bend 360° pivotable

We recommend one bend trolley for every 2 meters of profile. Between two bend trolleys is 2,5m GeoFlex Exhaust hose.

07-824	Bend trolley 100 – 360° pivotable
07-823	Bend trolley 125 – 360° pivotable
07-822	Bend trolley 150 – 360° pivotable

One bearing for every 3 meters of C-profile e.g. 10 m C-profile needs to be fitted with two 07-818 and two 07-817.

01-340	C-profile for festoon, length= 7,0m
07-828	Connection for C-profile
07-818	Bracket for C-profile. M10 thread - end stop included
07-817	Bracket for C-profile. M10 thread

Tip: By tilting the C-profile 2-7° the hose will automatically return



## Rail system – for vehicles with vertical exhaust pipes



Art. No.	Description
07-990	Channel duct system for emergency vehicles L = 6.0 m – complete set incl. 2 slidable, self-centering suspension brackets for the ceiling, inlet guide and exhaust adapter. The suspension bracket is height adjustable from 1.0 – 2.5m. The channel duct system is 500 mm slidable to both sides. The exhaust adapter may be mounted on exhaust pipes from app. 95 – 120 mm. The channel duct system for emergency vehicles is connected to the duct system via an ø250 mm reduction piece at the end.
07-991	Channel duct system for emergency vehicles L = 9.0 m – complete set incl. 2 slidable, self-centering suspension brackets for the ceiling, inlet guide and exhaust adapter. The suspension bracket is height adjustable from 1.0 – 2.5m. the channel duct system is 500 mm slidable to both sides. The exhaust adapter may be mounted on exhaust pipes from app. 95 – 120 mm. The channel duct system for emergency vehicles is connected to the duct system via an ø250 mm adapter at the end.

Other models available on request

## Emergency Rail System- type FBER



Art. No.	Description
07-995	Emergency rail system L = 7,0 m – complete solution including horizontally moveable profile, suspension bracket, hose and inlet guide. The extraction will follow the exhaust pipe all the way to the end of the rail. 10 m ø160 mm compressable hose is suspended for every 0,7 m. Max. temp. 150°C.
07-996	As above but for vehicles with side mounted exhaust pipes. Electromagnetic detachment system.
07-997	As above but for vehicles with side mounted exhaust pipes. Pneumatic detachment system
07-998	Complete extraction rail 6m long (galv), with ø100 mm hose and automatic decoupling
07-999	Complete extraction rail 6m long (galv), with ø150 mm hose and automatic decoupling
19-115	Pressure sensor for exhaust gas extraction. Can be used to turn fan/damper on/off. The use of damper is required

## Automatics for emergency vehicles



Art. No.	Description
19-111	Control panel for remote controlled transmitter. Automatically starts the fan, when the car is started. Range 50-100 m, subsequently the fan is turned off.
19-110	Wireless transmitter for start/stop of the fan. To be connected to 24V battery on the vehicle.

## Exhaust nozzles



Art. No.	Description	Exhaust	Hose Conn.	Weight
SK - nozzle - Powder coated steel with flap and opening for CO-probe.				
06-008	SK-80	ø77	ø80	1,30 kg
06-009	SK-100	ø97	ø100	2,05 kg
06-029	SK-125	ø122	ø125	3,05 kg
06-028	SK-150	ø147	ø150	3,10 kg



HT - nozzle - Powder coated steel w. vice grip. For very hot exhaust.				
06-328	HT-100	ø80	ø100	1,6 kg
06-329	HT-125	ø105	ø125	1,9 kg
06-330	HT-150	ø140	ø150	2,15 kg
06-331	HT-200	ø180	ø200	2,7 kg



S - funnel shaped rubber nozzle.				
06-168	S-65/90	ø90	ø80	0,65 kg
06-168A	S-65/90, with tight damper	ø90	ø80	1,35 kg
06-167	S-80/130	ø130	ø80	0,80 kg
06-167A	S-80/130, with tight damper	ø130	ø80	1,50 kg
06-166	S-100/150	ø150	ø100	0,85 kg
06-166A	S-100/150, with tight damper	ø150	ø100	1,40 kg
06-169	S-125/150	ø150	ø125	0,90 kg
06-169A	S-125/150, with tight damper	ø150	ø125	1,45 kg



SA - funnel shaped rubber nozzle. With vice grip and net.				
06-163	SA ø100/150	ø150	ø100	1,45 kg
06-163A	SA ø100/150, with tight damper	ø150	ø100	2,00 kg
06-164	SA ø125/190	ø190	ø125	2,10 kg
06-164A	SA ø125/190, with tight damper	ø190	ø125	3,35 kg
06-165	SA ø150/190	ø190	ø150	1,90 kg
06-165A	SA ø150/190, with tight damper	ø190	ø150	3,15 kg
06-160	SA ø100/150mm w. automatic damper	ø150	ø100	2,05 kg
06-161	SA ø125/190mm w. automatic damper	ø190	ø125	3,05 kg
06-162	SA ø150/190mm w. automatic damper	ø190	ø150	2,85 kg

Note: Standard automatic damper shuts off 90% of the airflow.



SE - Oval rubber nozzle with vice grip and a 60° bend.				
For cars				
06-170	SE-75/150	150/75	ø80	1,75 kg
06-171	SE-100/150	150/75	ø100	1,70 kg
06-172	SE-125/150	150/75	ø125	1,75 kg
For lorries				
06-173	SE-125/200	200/120	ø125	2,40 kg
06-174	SE-150/200	200/120	ø150	2,60 kg



SEI - oval rubber nozzle for car with exhaust pipe integrated in bumper.				
06-180	SEI-100/150 - For cars	165/88	ø100	2,30 kg
06-181	SEI-150/200 - For lorries	165/88	ø150	2,70 kg

## Exhaust nozzles



Art. No.	Description	Exhaust	Hose Conn.	Weight
06-182	SFI-100/200 with internal gripper	ø100	ø200	2,80 kg
06-184	SFI-150/200 with internal gripper	ø150	ø200	2,85 kg

### PO - Oval rubber nozzle with 60° bend

06-193	PO-80/130	125/65	ø80	0,85 kg
06-195	PO-80/130, with tight damper	125/65	ø80	1,55 kg
06-194	PO-100/130	125/65	ø100	0,65 kg
06-196	PO-100/130, with tight damper	125/65	ø100	1,20 kg

### GeoFlexGrip - Oval rubber nozzle, which will close when not in use.

06-140	GeoFlexGrip 140/25	ø75	ø100	0,55 kg
06-139	GeoFlexGrip 180/30	ø100	ø100	0,90 kg
06-142	GeoFlexGrip 240/15, damper recommended	ø125	ø150	1,30 kg

### SB - Round rubber nozzle with bellows for hand pump or compressed air.

06-350	SB 100/80	ø100	ø80	0,90 kg
06-354	SB 100/100	ø100	ø100	0,90 kg
06-355	SB 160/150	ø160	ø150	1,30 kg
06-360	SB 200/150	ø200	ø150	1,60 kg
06-360A	SB 250/150	ø250	ø150	2,00 kg

### SBM - Oval rubber nozzle with bellows for hand pump or compressed air.

06-364A	SBM 120/40 (mini cars)	120/40	ø80	0,85 kg
06-364B	SBM 120/40 (mini and smaller cars)	120/40	ø100	0,70 kg
06-368A	SBM 200/100 (smaller lorries with stroke bore less than 3,0 l)	200/100	ø125	1,35 kg
06-368B	SBM 200/100 (lorries)	200/100	ø150	1,60 kg

### SBM - Oval rubber nozzle with bellows for hand pump or compressed air. With 45° bend.

06-365A	SBM 150/80 (small and medium sized cars)	150/80	ø100	1,00 kg
06-365B	SBM 150/80 (medium and larger cars less than 3,0 L)	150/80	ø125	1,10 kg

### SBI - internal nozzles for newer cars with inaccessible exhaust pipes, like Volvo V60, Mercedes C, Ford Mondeo, Audi A6 and Porsche Cayenne. Ask for details.

#### Oval rubber nozzle with bellows for hand pump or compressed air.

06-380	SBIM 131/36	131/36	ø100	0,90 kg
06-381	SBIV 126/50	126/50	ø100	0,90 kg
06-382	SBIA 166/48	169/48	ø100	1,20 kg

#### 06-369 Hand pump for compressed air nozzle

#### 06-369A Fast air vent valve for compressed air nozzle

#### 06-379 Slide valve for compressed air nozzle

### Smart Cool SC is an adapter with damper and with built-in cooling air control.

12-040	SmartCool SC-100 w. damper + extra cooling air	ø100	ø100	0,90 kg
12-041	SmartCool SC-125 w. damper + extra cooling air	ø125	ø125	1,00 kg
12-042	SmartCool SC-150 w. damper + extra cooling air	ø150	ø150	1,35 kg
12-043	SmartCool SC-200 w. damper + extra cooling air	ø200	ø200	2,00 kg

## Exhaust nozzles

Art. No.	Description
06-363	Pressure regulator for nozzle SB with pressure gauge, $\varnothing$ 10 mm push-in fittings and mounting bracket
06-356	Compressed air supply set for hose reel L=max.10 m
06-357	Compressed air feeding set with garland for channel duct: L = max 6 m
06-358	L = max 12 m
06-359	L = max 18 m
06-356A	Compressed air feeding set for hose garland, L=max.18 m
07-035	AU2 $\varnothing$ 150 mm height adjustable holder. Well suited for test stands.
07-040	AU2 $\varnothing$ 200 mm height adjustable holder. Well suited for test stands.
06-250	FBE hose cart $\varnothing$ 100 mm height adjustable and easy to place
06-251	FBE hose cart $\varnothing$ 125 mm height adjustable and easy to place
06-252	FBE hose cart $\varnothing$ 150 mm height adjustable and easy to place
Y-coupling set for cars with dual exhaust pipe.	
06-389	Y-piece 100/100/45° complete, 2 $\varnothing$ 100 GeoFlex Exhaust 1,25m hoses
06-390	Y-piece 100/100/45° complete with click coupling VL, 2. $\varnothing$ 100 GeoFlex Exhaust 1,25m hoses
06-390A	Y-piece 100/100/45° complete with click coupling VL, 2. $\varnothing$ 100 GeoFlex Exhaust 1,25m High temperature hoses
Note: Nozzles not included.	
06-200	Extended nozzle $\varnothing$ 125/250 - H = 2m. Well suited for construction equipment with vertical exhaust pipe.
06-200A	Extended nozzle $\varnothing$ 125/250 - H = 2m. Well suited for construction equipment with vertical exhaust pipe. With 300°C hose.
06-202	Extended nozzle $\varnothing$ 150/250 - H = 2m. Well suited for agricultural machinery and trucks with exhaust pipe upwardly. With 300°C hose.
01-870	Smart Exhaust Arm, Telescopic arm with nozzle
07-411	Hose trolley type 25





## Hood for hose reel and more



Art. No.	Description	Weight
10-244	Ø160 mm hood with magnet	1,7 kg
10-246	Ø200 mm hood with magnet	1,9 kg
10-245	Ø160 mm hood with magnet incl. adaptor ø150 mm	1,9 kg



12-006	Tight damper ø100 mm	0,19 kg
12-012	Tight damper ø125 mm	0,25 kg
12-008	Tight damper ø160 mm	0,39 kg
12-009	Tight damper ø200 mm	0,55 kg



06-014	Welding hood ø80 with magnet	1,0 kg
06-015	Welding hood ø80 with magnet and tight damper	1,2 kg
06-020	Welding hood ø100 with magnet	1,1 kg
06-021	Welding hood ø100 with magnet and tight damper	1,3 kg
06-025	Welding hood ø125 with magnet	1,3 kg
06-026	Welding hood ø125 with magnet and tight damper	1,5 kg



06-051	MINI-hood ø80 with magnet	0,65 kg
06-052	MINI-hood ø80 with magnet and tight damper	0,65 kg
06-053	MINI-hood ø100 with magnet	0,65 kg
06-054	MINI-hood ø100 with magnet and tight damper	0,65 kg



10-265	Flange f/hood-ø125 hose
10-266	Flange f/hood-ø160 hose
10-267	Flange f/hood-ø200 hose

Custom hoods available on request. Please enquire.

Vacuum cup instead of magnet available. Please enquire.

## Extraction Hoods for train



Extraction Hood for train

## Extraction Hoods for train

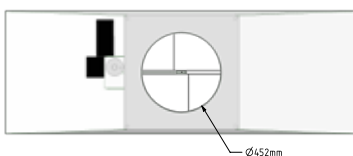

Motor: 3x400V 50Hz. Standard supplied with out control panel, but can be supplied upon request. Recommended Airflow: App. 3.000m<sup>3</sup>/h

Art. No.	Description
02-200	Hood for train exhaust 2000 x 700 mm

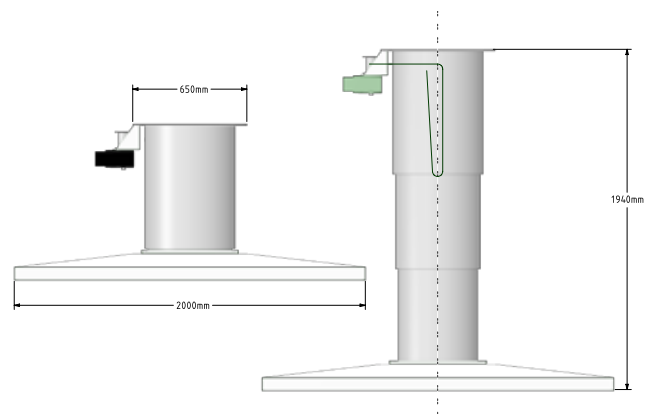
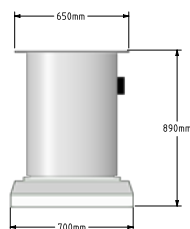

# EXTRACTION HOODS



Extraction hood with light

Do you have problems with smoke and fumes, and is it not possible to use an extraction arm? Then a hood in galvanized construction could be the right solution.

We offer two sizes: Hood 1200 x 1000 x 400 mm recommended airflow: 1.000-1.500 m<sup>3</sup>/h and hood 2200 x 1000 x 400 mm recommended airflow: 2.000-3.000 m<sup>3</sup>/h

Option: Can be offered with LED spots.

Other sizes available upon request.

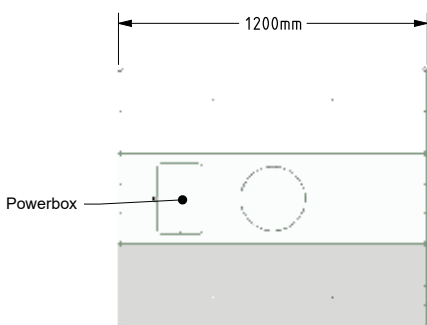
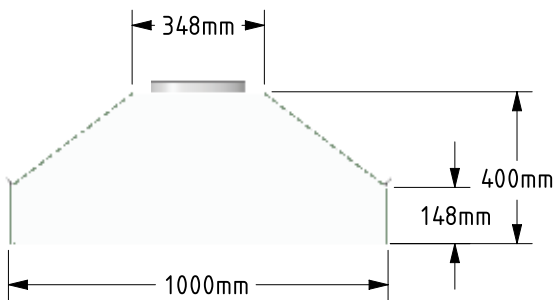
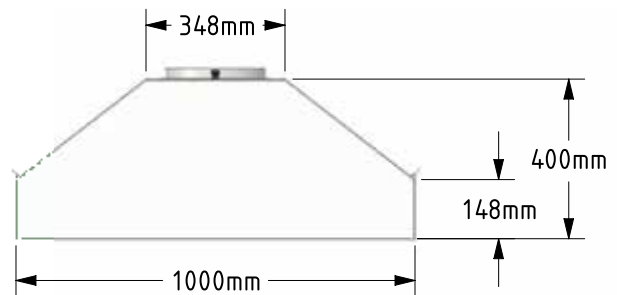

02-210 Hood

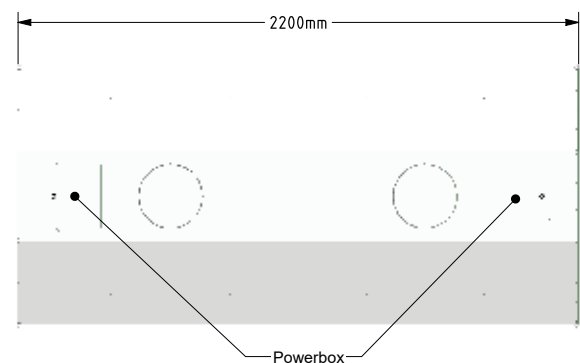

02-211 Hood

## Extraction hoods with edge extraction



Do you have problems with smoke and fumes, and is it not possible to use an extraction arm? Then a hood in galvanized construction, could be the right solution. We offer two sizes: Hood 1200 x 1000 x 400 mm recommended airflow: 1.000-1.500 m<sup>3</sup>/h and hood 2200 x 1000 x 400 mm recommended airflow: 2.000-3.000 m<sup>3</sup>/h  
Option: Can be offered with LED spots.

Art. No.	Description
02-210	Hood 1200 x 1000 x 400 mm, recommended airflow: 1.000-1.500 m <sup>3</sup> /h, connection 1xø250 mm
02-211	Hood 2200 x 1000 x 400 mm, recommended airflow: 2.000-3.000 m <sup>3</sup> /h, connection 2xø250 mm

## Accessories

Art. No.	Description
02-215	Light kit consisting of 4 lights, 7 watt per. bulb, 24V, incl. electronic transformer
02-216	Light kit consisting of 8 lights, 7 watt per. bulb, 24V, incl. electronic transformer

## Extraction hoods in modules



Geovent manufactures hoods in customised or standard versions. They are available with different kinds of suspension types, depending on the installation plans – on a wall or from the ceiling. The airflow can be adapted to the individual job by adjusting the width of the slit as well as the diameter measurement of the connection to the Spiro pipe. As standard, we offer two sizes: hood 1275 x 700 x 250 mm with an airflow from 100 m<sup>3</sup>/h and 2550 x 700 x 250 mm with an airflow from 200 m<sup>3</sup>/h and upwards. These hoods have LED spots. As standard, the slit is 20 mm. Upon request, the slit can be made in different measurements. As shown on the picture, the hoods can be installed in series, making an almost endless length of the actual hood possible.

Art. No.	Description
02-212	Hood 1275x700x250mm with LED spots
02-213	Hood 2550x700x250mm with LED spots

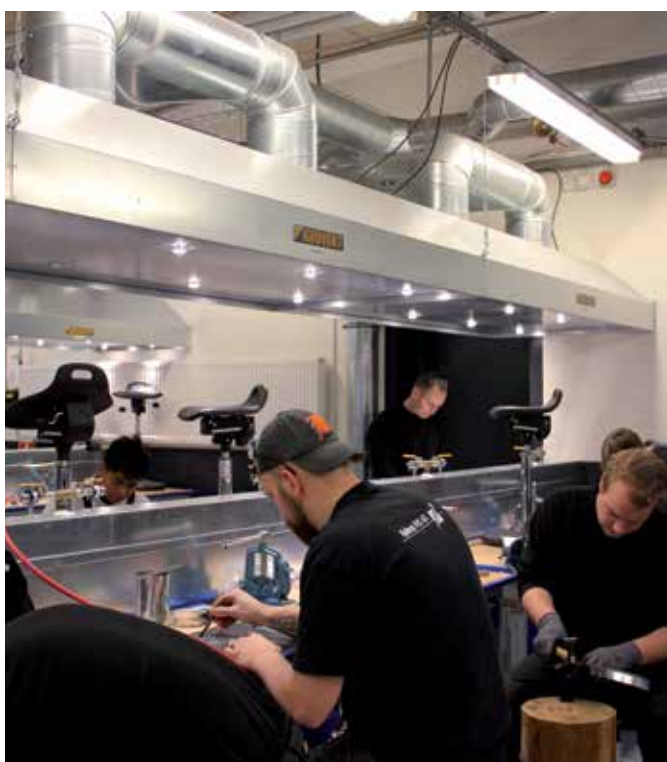

Extraction Hood at a school



As seen in the picture, the hoods can be mounted in series so that the length of the hood itself can almost become infinite.



## Examples of equipment for emergency vehicles

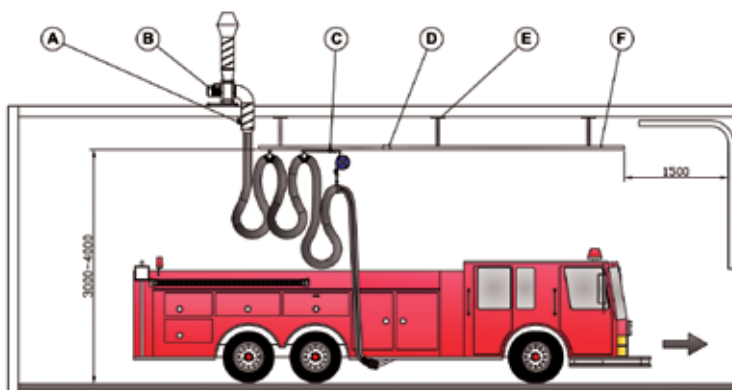

### GARLAND RAIL W. AUT. DETACHMENT

- A: Spiro duct  $\varnothing$ 160 mm with reduction valve for compressed air
- B: Fan MSFG-200-3, 1.1kW – capable of supplying up to 2.100 m<sup>3</sup>/h air.
- C: Balancer trolley. The trolley slides horizontally in the direction of travel.
- D: Connecting piece for rail system. The system consists of 6 meter pieces to be assembled to the required length.
- E: Suspension bracket for the mounting of the rail system in the ceiling.
- F: Release device, transmitting a signal to reduce the pressure in the nozzle, and then the nozzle is detached from the exhaust pipe.

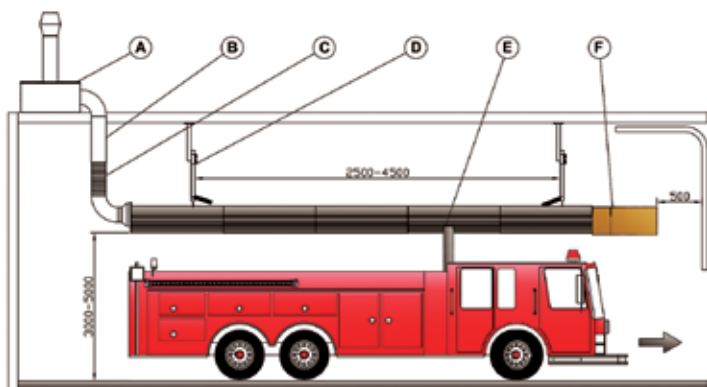

### CHANNEL DUCT FOR EMERGENCY VEHICLES

- A: Box fan – for the extraction from a vehicle, MSFG-200-3, 1.1kW – Max 2.100 m<sup>3</sup>/h.
- B: Fixed spiro duct connection.
- C: Flexible hose, securing the regulation/movement of the channel duct.
- D: Suspension bracket, which can slide the channel duct in the same direction as the vehicle.
- E: The vertical exhaust pipe of the vehicle.
- F: Inlet guide to catch the exhaust pipe in order for it to be guided into the channel duct. The system is activated via excess pressure.

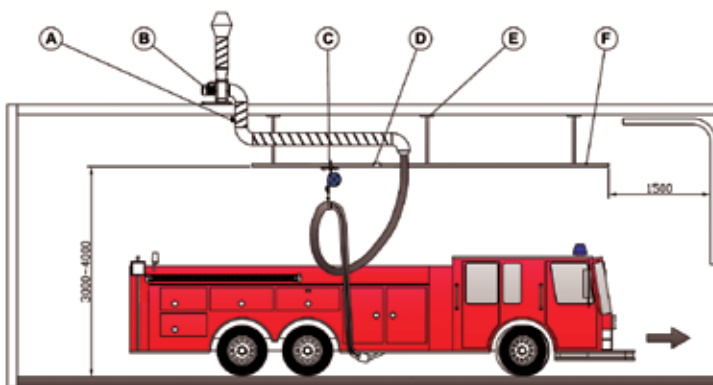

### GARLAND RAIL SYSTEM / C-PROFILE SYSTEM

- A: Spiro duct  $\varnothing$ 200 mm, reduction valve for compressed air.
- B: Fan MSFG-200-3, 1.1 kW – capable of supplying up to 2.100 m<sup>3</sup>/h air.
- C: Spring balancer holder with wheels, capable of sliding horizontally in the rail system.
- D: Connecting piece for rail system. The system consists of 6 meter pieces to be assembled to the required length.
- E: Suspension bracket for the mounting of the rail system in the ceiling.
- F: Release device, transmitting a signal to reduce the pressure in the nozzle, and then the nozzle is detached from the exhaust pipe.

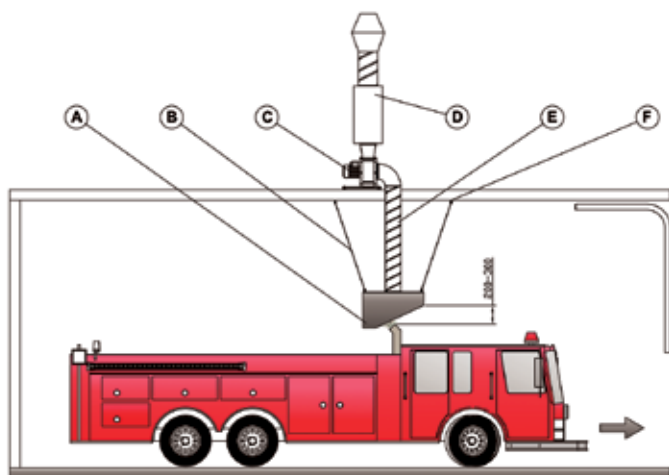

### EXTRACTION HOOD

- A: Extraction hood 1000 x 1000 x 800 mm with vertical outlet and suspension bracket.
- B: Steel wire with turnbuckles.
- C: Fan MSFG-200-3 – for the extraction from one vehicle.
- D: Silencer  $\varnothing$ 250 mm.
- E: Spiro duct  $\varnothing$ 200 mm.
- F: Ceiling bracket

## Examples of equipment for emergency vehicles

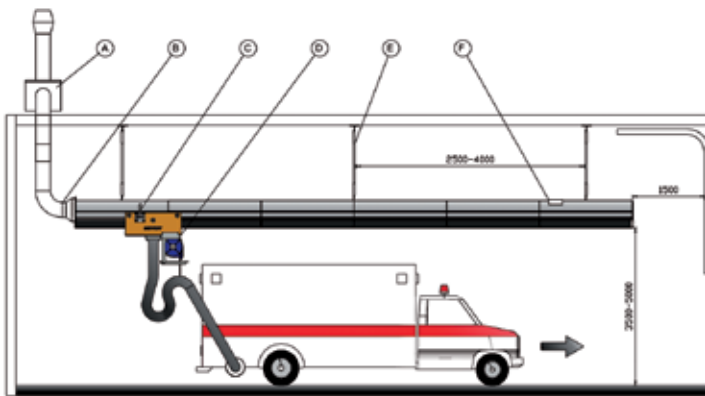

### CHANNEL DUCT W. MECHANICAL REL. SYSTEM

- A: Box fan - MSFG-200-3
- B: Transition piece to round channel from the duct.
- C: Mechanical release system; releases the nozzle from the exhaust pipe at the end of the channel duct. The mechanism works by means of a steel wire releasing the vice grip on the nozzle.
- D: Spring balancer to facilitate the operation of the equipment and which ensures that the hose is not in the way.
- E: The suspension brackets must be fixed at intervals of 2500 to 4000 mm in order to secure the stable installation.
- F: Release station, activating the wire set in such a way that the nozzle is released just before the trolley reaches the end of the channel duct.

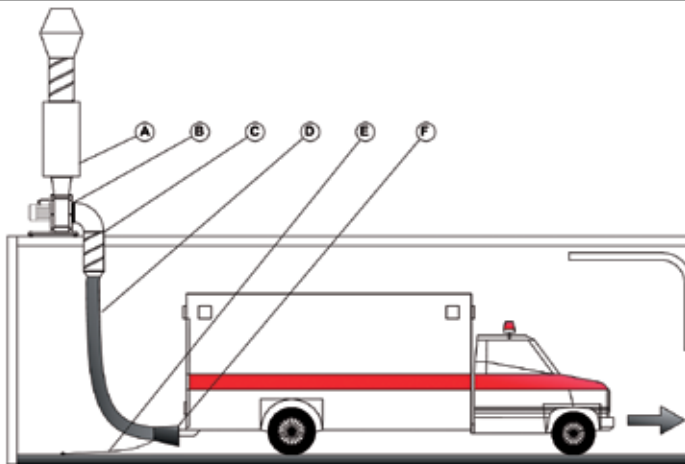

### CONICAL NOZZLE, FIXED TO THE FLOOR

- A: Silencer
- B: Fan MSFG-200-3, 1.1 kW, max. 2.100m<sup>3</sup>/h.
- C: ø200 mm spiro duct and bend.
- D: GeoFlex exhaust hose with a temperature resistance of up to 150°C.
- E: Wire, fixed to the floor, ensuring that the nozzle detaches from the vehicle.
- F: Rubber nozzle to be pushed over the exhaust pipe. Suits several exhaust pipe dimensions.

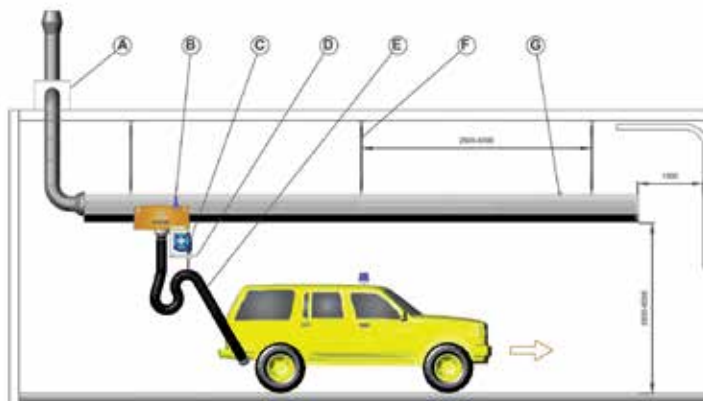

### CHANNEL DUCT W. PNEUMATIC DETACHMENT

- A: Box fan - MSFG-200-3 1.1 kW
- B: Activation switch, sending a signal to the control panel to start or stop the fan.
- C: Spring balancer, securing easy operation of the equipment and that the hose is not in the way.
- D: GeoFlex exhaust pipe with a temperature resistance of up to 150°C. The lower part of the hose is a safety pull-out coupling, securing that the nozzle is released in case of defects.
- E: Wire switch LWS for the start/stop of the fan.
- F: The suspension brackets must be fixed at intervals of 2.500 to 4.000 mm in order to secure the stable installation.
- G: Bracket, which at the end station sends a signal to reduce the compressed air in the nozzle so that immediately hereafter it is released automatically from the vehicle.

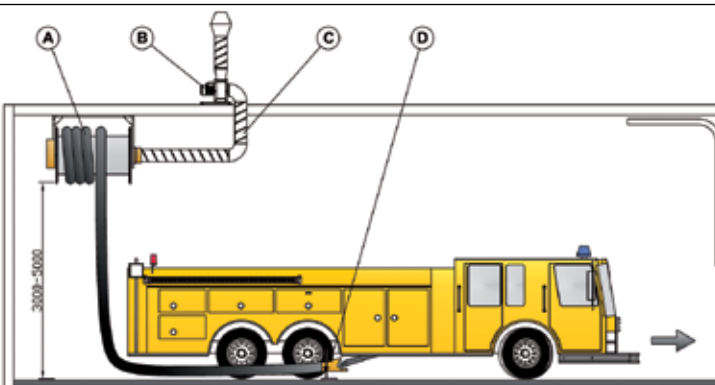

### HOSE REEL WITH AU2 FUNNEL

- A: Hose reel with 10 meters of ø150 mm GeoFlex exhaust (max 150°C).
- B: Fan MSFG-200, 1.1kW - Max 2.100 m<sup>3</sup>/h.
- C: Spiro pipe ø200 mm.
- D: AU2 funnel, placed immediately behind the exhaust pipe



### SINGLE DUCT WITH MOTOR DRIVEN HOSE TROLLEY FOR CHANNEL DUCT

Channel duct system with motor driven trolley. When the hose is pulled down and the nozzle is connected to the car exhaust pipe, the fan is switched on automatically. The trolley is pulled forward by the hose connected to the exhaust pipe. When the trolley reaches the end of the duct, the nozzle is disconnected automatically, the fan turns off and the trolley returns to the starting point.



### PNEUMATIC RELEASE SYSTEM

Pneumatic release system with automatic start/stop of the fan and compressed air nozzle, which is automatically released, when the trolley reaches the end of the channel duct. The system is available with standard brackets, adjustable to any ceiling. The compressed air nozzle fits perfectly on the exhaust pipe and is completely tight. The nozzle can be used in combination with a motor driven trolley for automatic return of the trolley.



### INLET GUIDE

Channel duct system for fire engines with vertical exhaust pipes.

Horizontally sliding suspension makes driving to and from the garage effortless. Even if the vehicle is not completely parallel to the system, when driving into the garage, the channel duct will slide in the same direction as the vehicle. The inlet guide is placed at the end of the channel duct. When parking the vehicle, the exhaust pipe of the vehicle must point in the direction of the inlet guide, and subsequently the channel duct will follow the exhaust pipe and remove the exhaust gasses.

The Channel Duct Systems are highly customizable – Enquire for further possible solutions

# WING ARM



The classic point extraction arm.  
The WING arm construction dates more than 40 years back, but with improvements over the years, it is still one of the best choices when selecting a new extraction arm.

**Lengths:** 2, 3 and 4 m.  
Up to 9 m, when using an extension arm.

**Dimensions:**  
ø160 and ø200 mm

## Dimensions WING arm

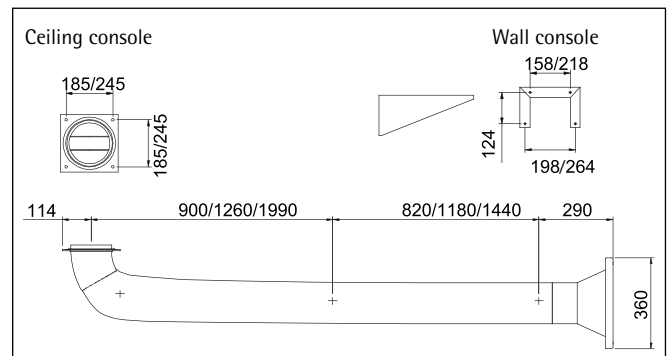

## Extension arms

All arms may be extended with an extension arm.  
The 2 meter long extension arm will generate a pressure drop of app 70 Pa at 1.000 m<sup>3</sup>/h.  
The 4,0 meter link extension arm shown will generate a pressure drop of app 200 Pa at 1.000 m<sup>3</sup>/h.



# COMPACT ARM

The Geovent COMPACT arm is the ideal solution when there is confined space for example in welding booths. The telescope function within the COMPACT arm offers the perfect balance between larger arms extraction capacity and smaller arms easy maneuverability. When you are done with the operation, simply move the arm up/away, and it does not take up any extra space.

The arm is supplied ready for installation in the ceiling (360° rotatable) or on wall (wall console required), together with separate fan or to central fan.

**Lengths:** 1-2m or 1,4-3m.  
Up to 8m, when using an extension arm.

**Dimensions:**  
ø160 and ø200 mm



White COMPACT arm, customized design.  
Ask for special design



Dimensions COMPACT arm

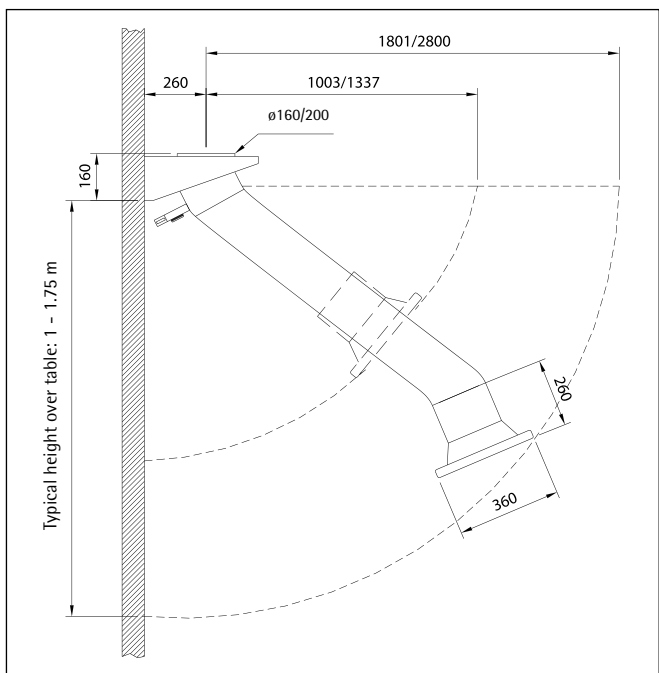



# ASA ARM



GEOVENT ASA-3 and ASA-4 extraction arms is used for welding fumes, grinding dust and various vapours, where the considerations for the operator are ease of positioning, ergonomics and efficiency.

The ASA arm is based on an externally articulated alu arm construction with gas spring, ensuring that it can easily and effortlessly be positioned in the desired position. The ASA-3 is supplied with flexible hose, where the ASA-4 is fitted with aluminum pipes.

Available in lengths 2,0 m, 3,0 m and 4,0 m.

With extension arm the range can be extended up to 8 m.  
We do not recommend ASA arm of 4 meters mounted on a Extension arm.

The ASA arms are also available in ATEX versions (ASX arm)

Arm	A	B	D	E	F	Hood	C	G
2,0 m	920	680	206	120	200	ø80	180	178
3,0 m	1420	1180	206	120	200	ø100	180	198
4,0 m	1870	1710	206	120	200	ø125	180	223
						ø160	318	360
						ø200	318	360



Dimensions ASA arm

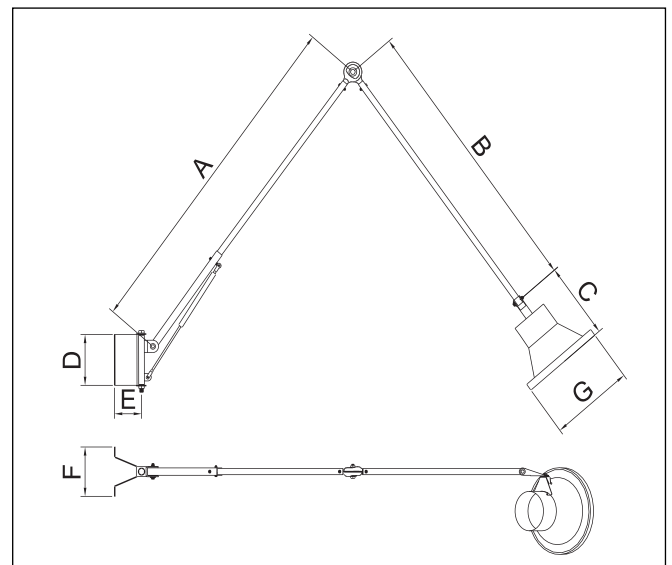

# FLEXI ARM



The unique design of the Geovent FLEXI arm has been developed especially for the purpose of removing polluted air from laboratories, schools, hospital environments, clinics, etc. By removing the polluted air directly at the source, the exposure of the employees to air causing local irritation and toxic vapors is minimized, resulting in a better working environment.

**Dimension:**  $\varnothing$ 100 mm or  $\varnothing$ 125 mm

**Length:** 1,0 or 1,5 meter

**Installation:** Wall, ceiling, table or cupboard

**Hose:** GeoFlex White (140°C)

Three friction joints as well as a 360° smooth-running swivel suspension secures that the arm may be positioned in any required position within the working area, thus resulting in easy and effortless use of the FLEXI arm.

## New version

FLEXI model FSK is for mounting horizontally, direct into a wall or cupboard. Used in laboratories, clinics etc. This model has a detachable version, so you can remove the arm when it is not needed.



A: FLEXI arm with bracket for table mounting and 330 x 445 mm polycarbonate hood.

B: The FLEXI arm is available with several different types of hood, both in aluminium and in clear polycarbonate. Here the arm is shown with an  $\varnothing$ 385 mm clear polycarbonate dome-shaped hood.

C: FLEXI arm, with bracket for wall mounting.

D: FLEXI arm, with bracket for ceiling mounting with 360° swivel. Standard bracket of 1.000 mm or custom, according to customer requirements.

E: FLEXI arm, mounted directly into laboratory cupboard. Complete arm, with hood and mounting bracket.

F: FLEXI arm FSK with horizontal attachment and it comes in two versions.



Custom project, with arms in black, and brackets designed according to customer requirements.

# PERMA ARM



Energy-efficient bends - the market's lowest pressure loss.  
Easy assembly and easy maintenance.

The perfect choice of arm for hairdressers, dentist, pharmacies, hospitals etc. The flexible self carrying construction consist of anodized aluminum pipes with 2 or 3 cast plastic joints.

In addition, the PERMA arm comes in a ESD approved version, suitable for the electronics industry a well as the chemical, plastics and mechanical industries.



PERMA arm with black joints





# ESA ARM



The ESA arm is designed with external support arm for easy positioning, ergonomics and low pressure drop. The support arm is made of extruded 6060 aluminum and the joints are of cast glass infused nylon. The arm joints are both supported with gas springs. The hood is made of aluminum for durability, and it is designed for maximum extraction and capture efficiency.

**Dimensions:**  $\varnothing$ 160 mm or  $\varnothing$ 200 mm

**Lengths:** 2 to 5 meters. At 4 and 5 meters an extension is fitted. Is available up to 8 meters length by using extension arm.

**Hose:** GeoFlex Weld (-10°C to +60°C - briefly 110°C)

### Recommended air flow

Hose Dimension  $\varnothing$ 160 mm

800-1000 m<sup>3</sup>/h

Hose Dimension  $\varnothing$ 200 mm

1000-2000 m<sup>3</sup>/h

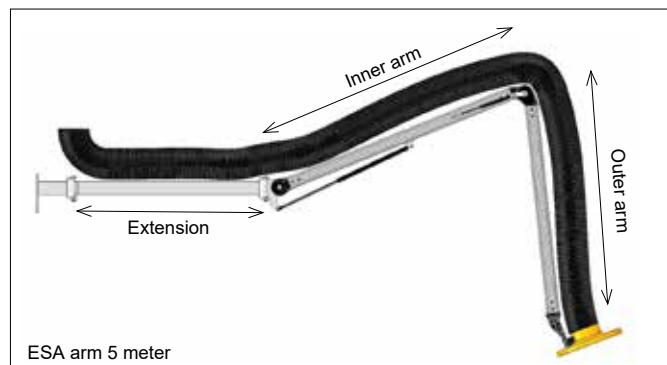

ESA Arm	Inner carrying arm (mm)	Outer carrying arm (mm)	Extension (mm)	Max. working radius (mm)	Max. Radius (mm)
2M	865	696		1600*	2000
3M	1365	1200		2700**	3000
4M	1365	1200	1000	3700**	4000
5M	1365	1200	2000	4700**	5000

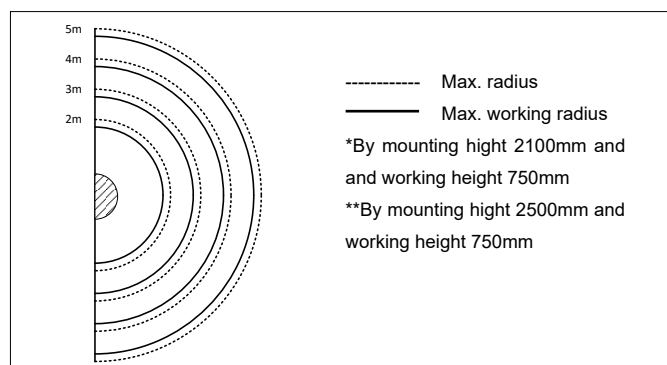

## WING arm, with internal articulated support arm



Note! Wall bracket not included  
- see accessories

### Art. No. Description

01-008	WING-arm 2,0 m $\phi$ 160 mm - rec. air flow 800 - 1.000 m <sup>3</sup> /h
01-009	WING-arm 3,0 m $\phi$ 160 mm - rec. air flow 800 - 1.000 m <sup>3</sup> /h
01-007	WING-arm 4,0 m $\phi$ 160 mm - rec. air flow 800 - 1.000 m <sup>3</sup> /h
01-007A	WING-arm 2,0 m $\phi$ 200 mm - rec. air flow 1.200 - 1.500 m <sup>3</sup> /h
01-008A	WING-arm 3,0 m $\phi$ 200 mm - rec. air flow 1.200 - 1.500 m <sup>3</sup> /h
01-009A	WING-arm 4,0 m $\phi$ 200 mm - rec. air flow 1.200 - 1.500 m <sup>3</sup> /h

## WING arm with quick-coupling and ball swivel joint

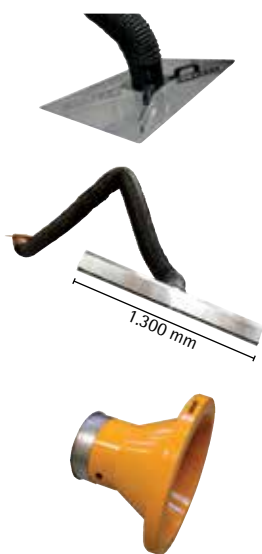

### Art. No. Description

01-202	Wing arm $\phi$ 160 mm, 2 m - with quick-coupling/ball joint - w/o hood
01-202A	Wing arm $\phi$ 200 mm, 2 m - with quick-coupling/ball joint - w/o hood
01-200	Wing arm $\phi$ 160 mm, 3 m - with quick-coupling/ball joint - w/o hood
01-200A	Wing arm $\phi$ 200 mm, 3 m - with quick-coupling/ball joint - w/o hood
12-243	Extraction hood for windscreen gluing 850x600 mm - Prepared for quick-coupling $\phi$ 160 mm
12-243A	Extraction hood for windscreen gluing 850x600 mm - Prepared for quick-coupling $\phi$ 200 mm
12-242	Panel fume extractor $\phi$ 160x1300 mm, aluminium. Prepared for quick-coupling
10-247	Detachable welding hood $\phi$ 160/385 mm, prepared for quick-coupling
10-248	Detachable welding hood $\phi$ 200/385 mm, prepared for quick-coupling
01-226	Counterpart for quick-coupling $\phi$ 160 mm (for hoses)
01-226A	Counterpart for quick-coupling $\phi$ 200 mm (for hoses)
91-289A	Quick-coupling $\phi$ 160 mm
91-290A	Quick-coupling $\phi$ 200 mm

## Pressure drop curves - WING arm

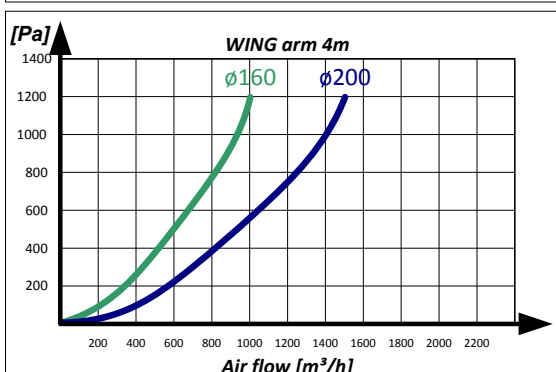
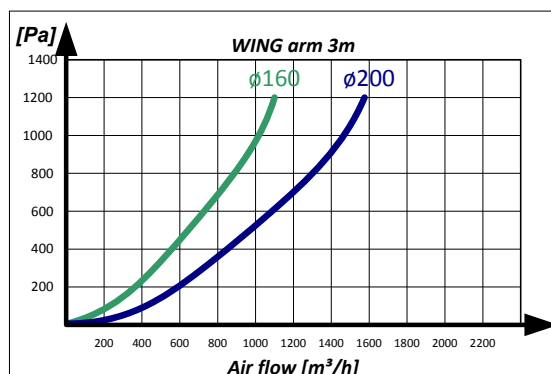
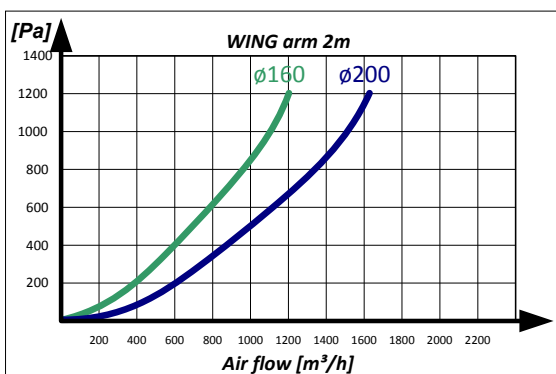



## COMPACT arm, with internal, telescopic support arm

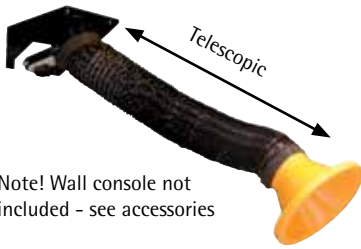

Note! Wall console not included - see accessories

### Art. No. Description

01-700	COMPACT arm 1 – 2 m., telescopic, ø160 mm
01-706	COMPACT arm 1,4 – 3 m., telescopic, ø160 mm
01-701	COMPACT arm 1 – 2 m., telescopic, ø200 mm
01-707	COMPACT arm 1,4 – 3 m., telescopic, ø200 mm

## Pressure drop curves - COMPACT arm

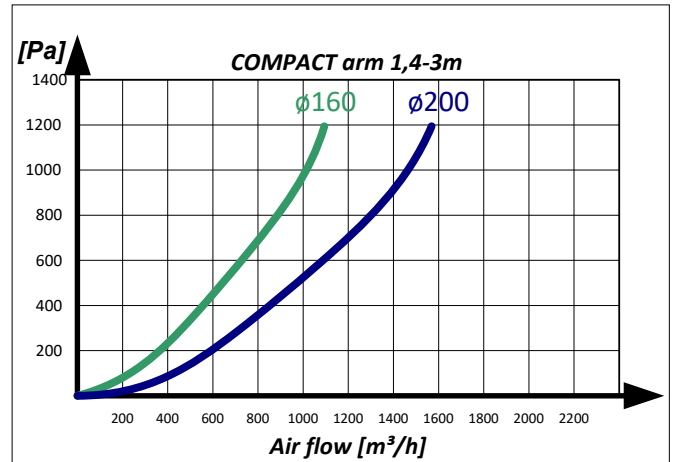
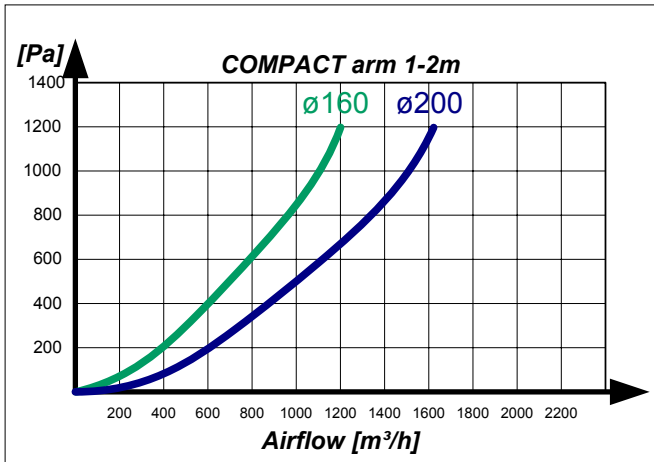

## Accessories for WING and COMPACT arm

### Art. No. Description

01-540	Wall console ø160 mm, 260 mm from wall
01-541	Wall console ø200 mm, 280 mm from wall
01-551	Wall Console Ø160 L=1m WING/COMPACT
01-552	Wall Console Ø200 L=1m WING/COMPACT
01-553	Wall Console L=1m ASA
01-160	Ceiling console ø160, 0,4-1,2M
01-161	Ceiling console ø160, 1,2-2,4M
01-162	Ceiling console ø200, 0,4-1,2M
01-163	Ceiling console ø200, 1,2-2,4M
12-008	Tight damper for hood - ø160 mm
12-009	Tight damper for hood - ø200 mm
01-172	LED set R2 incl. mesh - excl. trafo, ø125 mm
01-173	LED set R2 incl. mesh - excl. trafo, ø160 mm + ø200 mm
01-173A	LED set R3 - excl. trafo, ø160 mm + ø200 mm
01-179	Trafo 70 W electronic, 12V
10-253	Hood WING/COMPACT ø160 mm
10-256	Hood WING/COMPACT ø200 mm

Fan (MSQ) for mounting on wall console - see fan section.

Polycarbonate hoods for WING/COMPACT-arm - see under accessories for FLEXI arm.



## ASA-3 arm, with external, articulated arm, hose and gas spring



Art. No.	Description
ASA-01	ASA-3 arm 2,0 m ø80 mm, complete
ASA-11	ASA-3 arm 3,0 m ø80 mm, complete
ASA-02	ASA-3 arm 2,0 m ø100 mm, complete
ASA-12	ASA-3 arm 3,0 m ø100 mm, complete
ASA-22	ASA-3 arm 4,0 m ø100 mm, complete
ASA-03	ASA-3 arm 2,0 m ø125 mm, complete
ASA-13	ASA-3 arm 3,0 m ø125 mm, complete
ASA-23	ASA-3 arm 4,0 m ø125 mm, complete
ASA-04	ASA-3 arm 2,0 m ø160 mm, complete
ASA-14	ASA-3 arm 3,0 m ø160 mm, complete
ASA-24	ASA-3 arm 4,0 m ø160 mm, complete
ASA-31	ASA-3 arm 2,0 m ø200 mm, complete
ASA-33	ASA-3 arm 3,0 m ø200 mm, complete
ASA-35	ASA-3 arm 4,0 m ø200 mm, complete
12-005	Tight damper for hood - ø80 mm
12-006	Tight damper for hood - ø100 mm
12-012	Tight damper for hood - ø125 mm
12-008	Tight damper for hood - ø160 mm
12-009	Tight damper for hood - ø200 mm

The ASA-3 arm can also be delivered in ø50 mm or with special hose upon request.

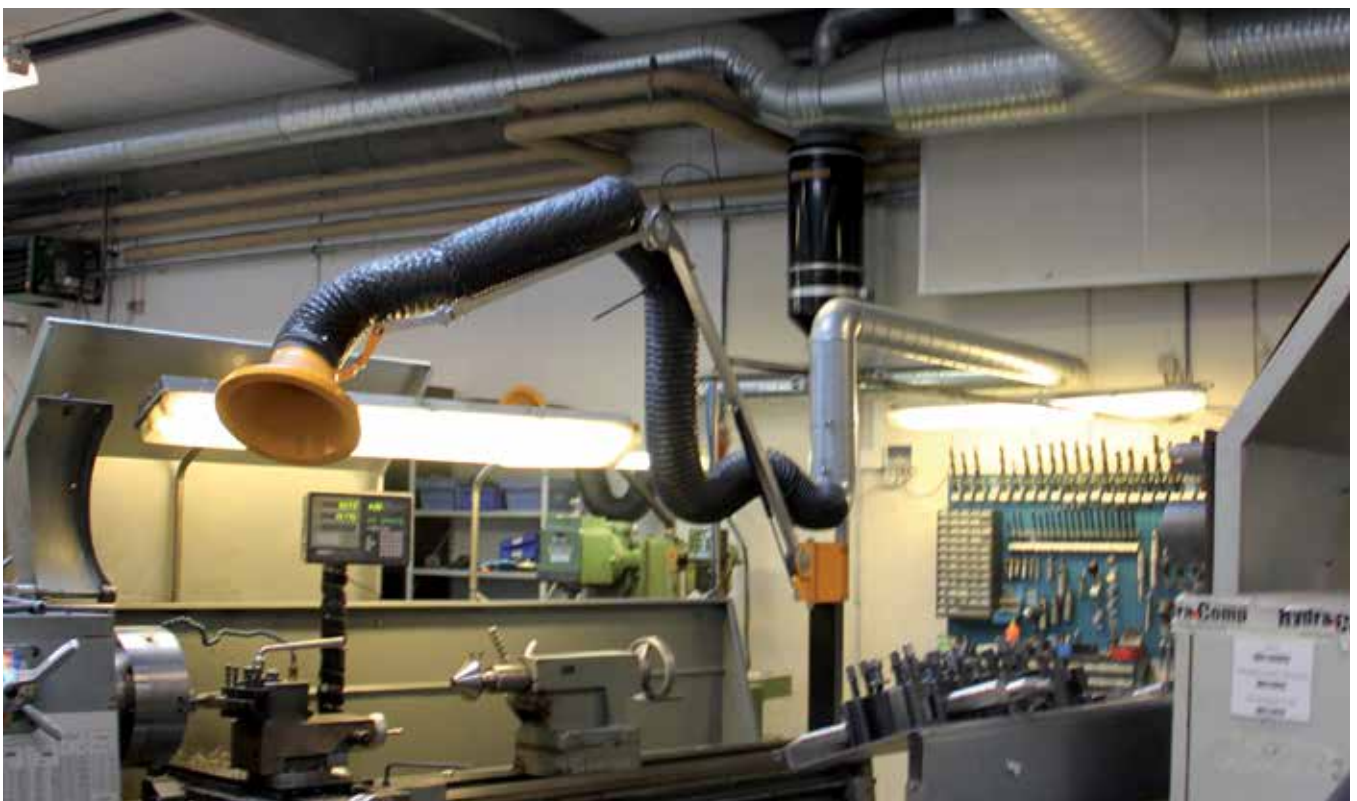

## ASA-4 arm, with external, articulated arm, alu pipe and gas spring



Art. No.	Description
ASA4-2-160	ASA4 arm 2m with $\varnothing$ 160mm alu-pipe, complete
ASA4-2-200	ASA4 arm 2m with $\varnothing$ 200mm alu-pipe, complete
ASA4-3-160	ASA4 arm 3m with $\varnothing$ 160mm alu-pipe, complete
ASA4-3-200	ASA4 arm 3m with $\varnothing$ 200mm alu-pipe, complete
ASA4-4-160	ASA4 arm 4m with $\varnothing$ 160mm alu-pipe, complete
ASA4-4-200	ASA4 arm 4m with $\varnothing$ 200mm alu-pipe, complete
12-008	Tight damper for hood - $\varnothing$ 160 mm
12-009	Tight damper for hood - $\varnothing$ 200 mm

### Pressure drop curves - ASA-3 arm

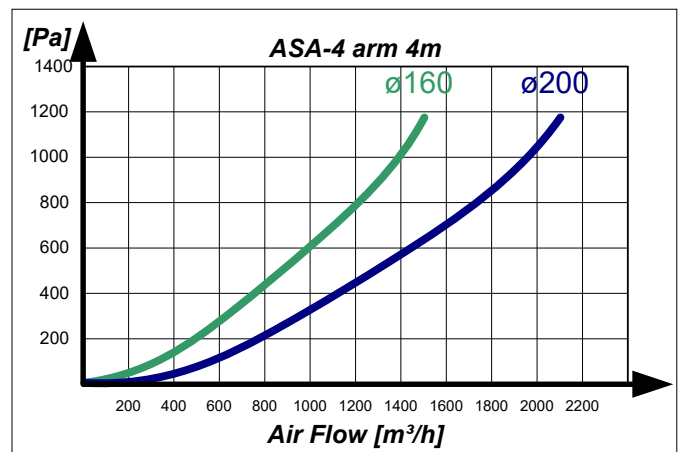
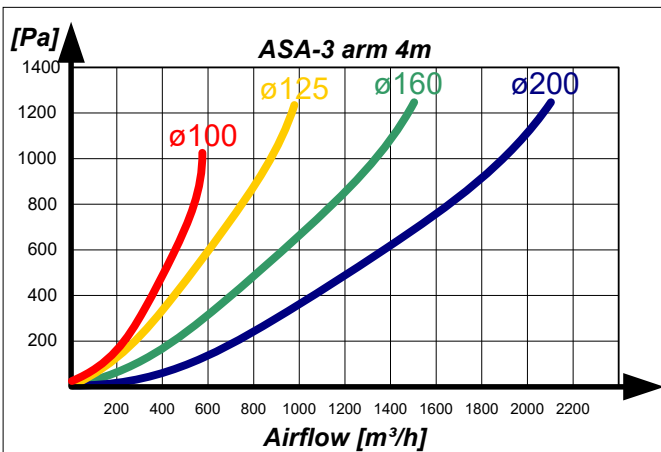
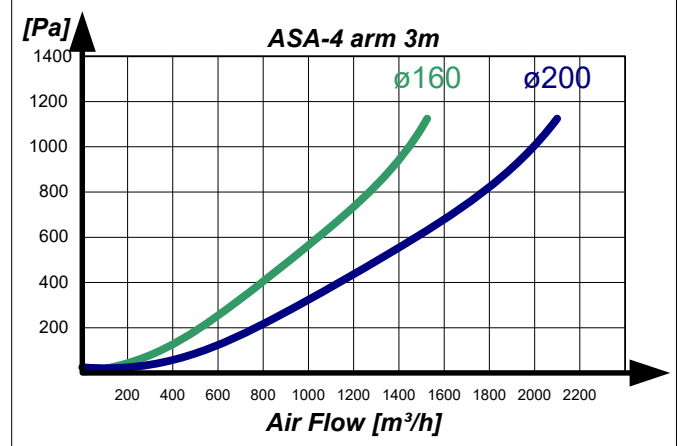
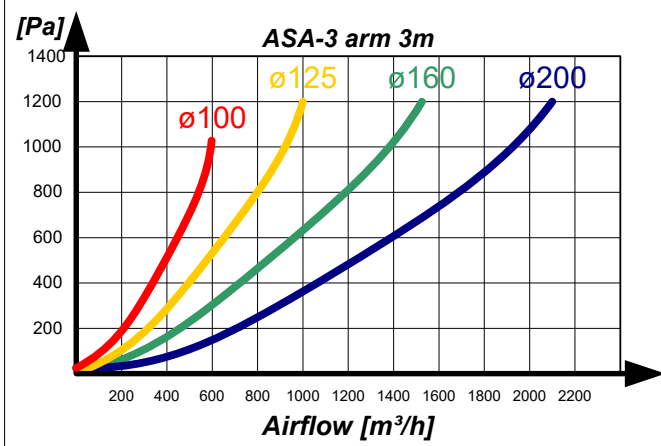
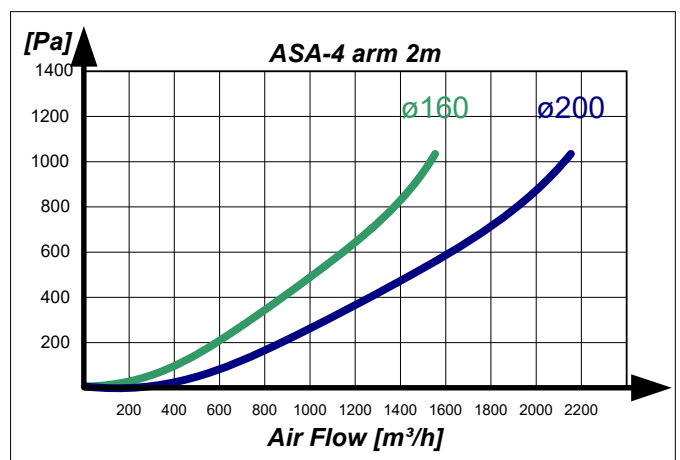
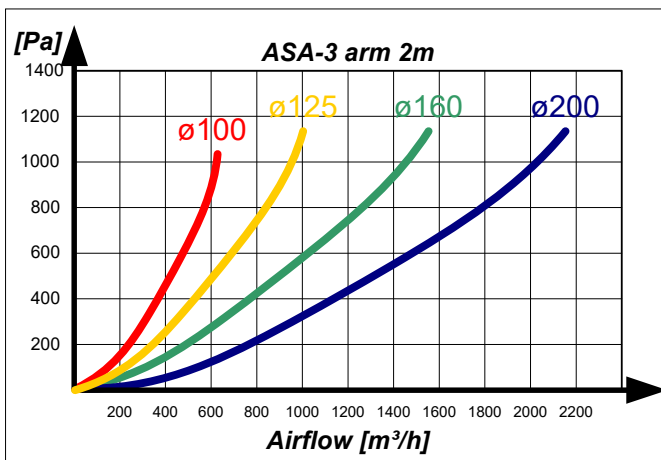

## ESA arm



### Art. No. Description

01-650	ESA Arm 2,0m $\varnothing$ 160 mm, complete arm incl. hose and wall bracket
01-651	ESA Arm 3,0m $\varnothing$ 160 mm, complete arm incl. hose and wall bracket
01-652	ESA Arm 4,0m $\varnothing$ 160 mm, complete arm incl. hose, wall bracket and extender
01-653	ESA Arm 5,0m $\varnothing$ 160 mm, complete arm incl. hose, wall bracket and extender

01-660	ESA Arm 2,0m $\varnothing$ 200 mm, complete arm incl. hose and wall bracket
01-661	ESA Arm 3,0m $\varnothing$ 200 mm, complete arm incl. hose and wall bracket
01-662	ESA Arm 4,0m $\varnothing$ 200 mm, complete arm incl. hose, wall bracket and extender
01-663	ESA Arm 5,0m $\varnothing$ 200 mm, complete arm incl. hose, wall bracket and extender

01-680	Universal bracket (floor/ceiling) L=400-2500 mm
01-681	Ceiling bracket, swivel 360°
01-682	LED light with on/off for fan

61-094	Motordamper GFD-160
61-095	Motordamper GFD-200

## Pressure drop curves - ESA arm

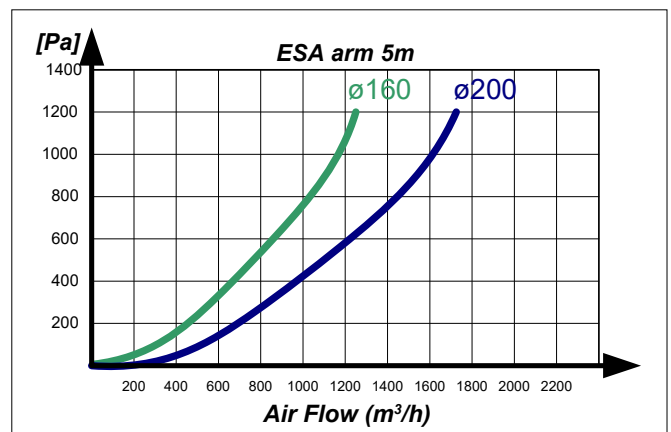
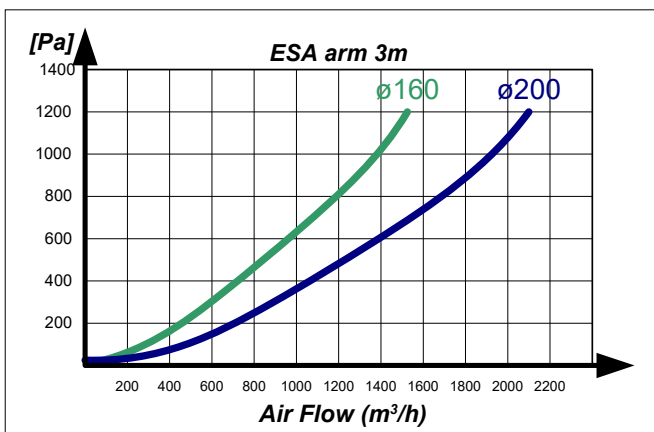
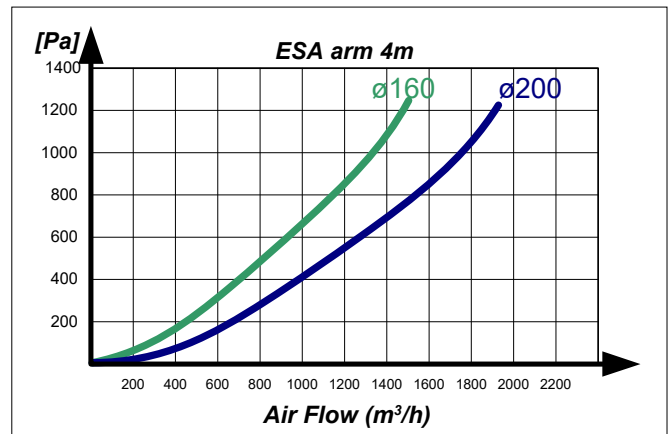
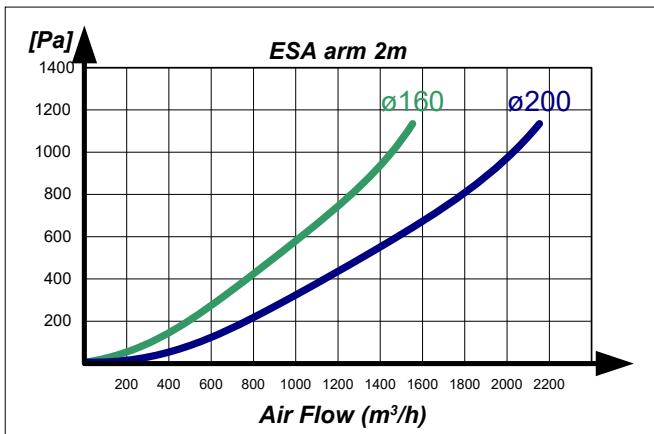



## MINI arm, with external, articulated arm and hose



Art. No.	Description
MINI-01	MINI arm 1,0 m ø80, complete
MINI-02	MINI arm 1,0 m ø100, complete
MINI-03	MINI arm 1,0 m ø125, complete
MINI-07	MINI arm 1,5 m ø80, complete
MINI-08	MINI arm 1,5 m ø100, complete
MINI-09	MINI arm 1,5 m ø125, complete
12-005	Tight damper for hood - ø80 mm
12-006	Tight damper for hood - ø100 mm
12-012	Tight damper for hood - ø125 mm
01-085	MINI arm 1,0m with wall/table console. Hose and hood not included.

See also accessories and hoods.

## Dimensions MINI arm

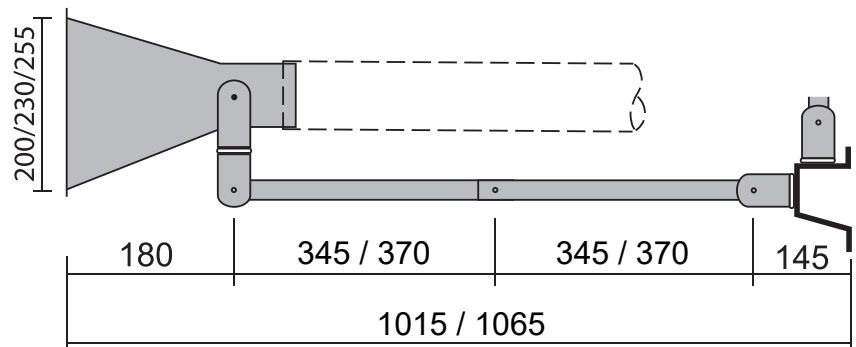

## Pressure drop curves - MINI arm

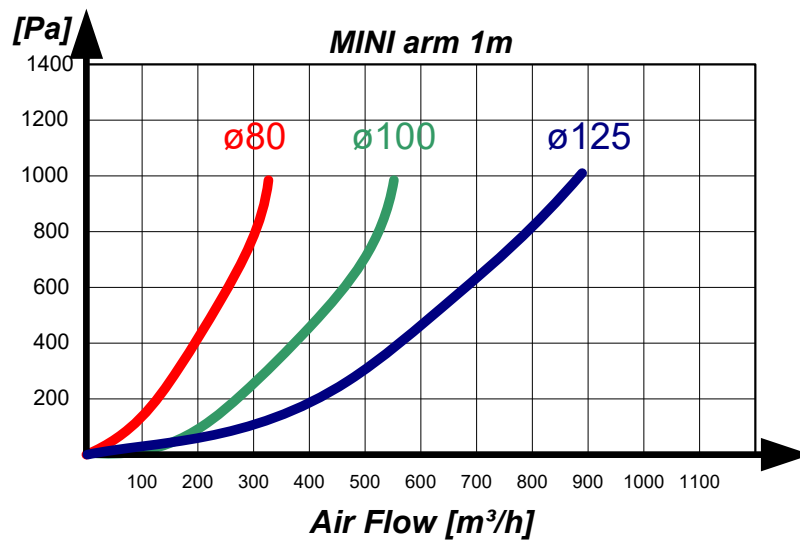

## Accessories for MINI, ASA-3 and ASA-4 arm



Art. No.	Description
06-121	Hood ø80 mm for ASA-3 and MINI arm
06-122	Hood ø100 mm for ASA-3 and MINI arm
06-123	Hood ø125 mm for ASA-3 and MINI arm
10-251	Hood ø160 for ASA-3 arm
10-255	Hood ø200 for ASA-3 arm
01-553	Wall Console L=1m ASA



## Extension arm



Extension arm with WING adapter.

Art. No.	Description
01-181	Extension arm 2m, 1-joint for ø160 mm, incl. wall console, excl. adapter
01-181A	Extension arm 2m, 1-joint for ø200 mm, incl. wall console, excl. adapter
01-182	Extension arm 3m, 1-joint for ø160 mm, incl. wall console, excl. adapter
01-182A	Extension arm 3m, 1-joint for ø200 mm, incl. wall console, excl. adapter
01-183	Extension arm 4m, 1-joint for ø160 mm, incl. wall console, excl. adapter
01-183A	Extension arm 4m, 1-joint for ø200 mm, incl. wall console, excl. adapter
01-184	Extension arm 5m, 1-joint for ø160 mm, incl. wall console, excl. adapter
01-184A	Extension arm 5m, 1-joint for ø200 mm, incl. wall console, excl. adapter
01-186	Extension arm 4m, 2-joint for ø160 mm, incl. wall console, excl. adapter
01-186A	Extension arm 4m, 2-joint for ø200 mm, incl. wall console, excl. adapter
01-195	Adapter for extension arm - WING / COMPACT ø160 mm
01-196	Adapter for extension arm - WING / COMPACT ø200 mm
01-197	Adapter for extension arm - ASA, universal
01-127	Floor column for mounting of extraction arm. (ASA-3, ASA-4, WING and COMPACT). H: 2500 mm Floor plate: 330x330 mm Please state type of arm when ordering.
01-127A	Floor column for mounting of extension arm. (ASA-3, ASA-4, WING and COMPACT). H: 3000 mm Floor plate: 800x800 mm Please state type of arm when ordering.
10-202	ASA-arm, w/ gas spring and wall console. 2,0 m w/o hood and hose
10-203	ASA-arm, w/ gas spring and wall console. 3,0 m w/o hood and hose
10-204	ASA-arm, w/ gas spring and wall console. 4,0 m w/o hood and hose

Smaller 2-joint extension arm can be made on request.

Adapter for WING / COMPACT



Adapter for ASA



Polycarbonate hoods for ASA-arm - see under accessories for FLEXI

## FLEXI arm, with internal, articulated arm and hose - $\varnothing$ 100 mm/ $\varnothing$ 125 mm

### STEP 1.

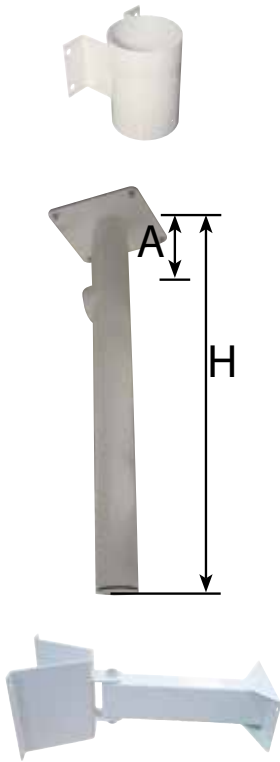

The extraction FLEXI arm's unique design is specifically designed for use in laboratories, hospital environments, clinics, etc. Positioning within the working area is done easily with the help of three friction joints and a 360° smooth-running rotary suspension.

Art. No.	Description
01-420	Wall console FLEXI - $\varnothing$ 100 mm
01-421	Table console FLEXI - $\varnothing$ 100 mm
01-422	Ceiling console FLEXI - $\varnothing$ 100 mm standard (H=1000 mm. A=125 mm) Table/ceiling bracket (direct ceiling mounting)
01-423	Ceiling console FLEXI - $\varnothing$ 100 mm Customized up to 1000 mm
01-424	Ceiling console FLEXI - $\varnothing$ 100 mm Customized 1000 - 2400 mm

Art. No.	Description
01-440	Wall console FLEXI - $\varnothing$ 125 mm
01-441	Table console FLEXI - $\varnothing$ 125 mm
01-442	Ceiling console FLEXI - $\varnothing$ 125 mm Standard (H=1000 mm. A=138 mm)
01-443	Ceiling console FLEXI - $\varnothing$ 125 mm Customized up to 1000 mm
01-444	Ceiling console FLEXI - $\varnothing$ 125 mm Customized 1000 - 2400 mm

01-585	FLEXI FVK Extension 0,5 meters (requiras wall console - 01-420 / 01-440)
01-586	FLEXI FVK Extension 1,5 meters

## FLEXI arm - $\varnothing$ 100 mm/ $\varnothing$ 125 mm

### STEP 2.



NB: Without console and hood.

Art. No.	Description
01-430	FLEXI arm $\varnothing$ 100 mm L=700 mm
01-431	FLEXI arm $\varnothing$ 100 mm L=1000 mm
01-432	FLEXI arm $\varnothing$ 100 mm L=1500 mm

NB: Without console and hood. See above.

01-450	FLEXI arm $\varnothing$ 125 mm L=700 mm
01-451	FLEXI arm $\varnothing$ 125 mm L=1000 mm
01-452	FLEXI arm $\varnothing$ 125 mm L=1500 mm

NB: Without console and hood. See above.

## FLEXI arm - Accessories / Spare parts

### STEP 3.



Art. No.	Description
01-455	Standard Hood $\varnothing$ 100 mm FLEXI
01-456	Standard Hood 125 mm FLEXI

12-006	Tight damper $\varnothing$ 100 mm for use in hood
12-012	Tight damper $\varnothing$ 125 mm for use in hood

FLEXI arm is by default powder coated white, RAL 9016 gloss 60.

STEP 3.



Art. No.	Description
Transparent PolyCarbonate hood ø500 mm:	
01-568	Hood w/ ø100 mm connection
01-569	Hood w/ ø125 mm connection
Transparent PolyCarbonate hood ø385 mm:	
01-566	Hood w/ ø100 mm connection
01-567	Hood w/ ø125 mm connection
Transparent PolyCarbonate hood ø280 mm:	
01-564	Hood w/ ø100 mm connection
01-565	Hood w/ ø125 mm connection
Transparent PolyCarbonate hood ø265 x 168 mm:	
01-558	Hood w/ ø100 mm connection
Transparent PolyCarbonate hood ø330 x 245 mm:	
01-556	ø100 mm connection
01-557	ø125 mm connection
For all PolyCarbonate hoods: please state which arm they are used for: A: ASA (ex. 01-568A) F: Flexi (ex. 01-568F) W: Wing/Compact (ex. 01-568W)	
PolyCarbonate hoods are available in ø160 mm and ø200 mm for ASA, WING and COMPACT	

Pressure drop curves - dimensions FLEXI arm

Guiding pressure drop:



Dimensions:

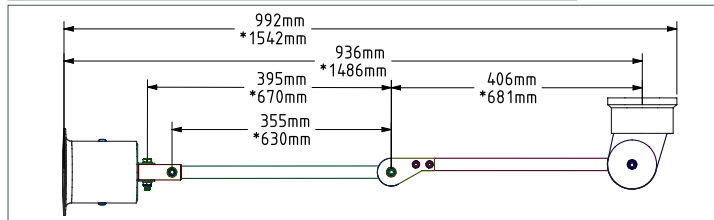
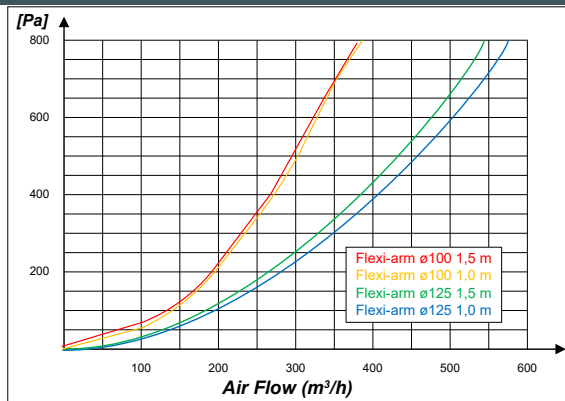

\* FLEXI arm 1,5 m

FLEXI arm FSK



FLEXI arm FSK

FLEXI arm FSK with horizontal attachment and it comes in two versions. One is fixed to the cabinet as standard (fx. 01-578S), the other arm is quick-release (fx. 01-578D) for easy detachment of the arm. Add S after the art. no. to get a fixed arm or add a D for a quick-release.

Art. No.	Description
01-578S/D	FLEXI arm FSK-ø100 mm 1,0 m., incl. hood and wall console
01-579S/D	FLEXI arm FSK-ø100 mm 1,5 m., incl. hood and wall console
01-580S/D	FLEXI arm FSK-ø125 mm 1,0 m., incl. hood and wall console
01-581S/D	FLEXI arm FSK-ø125 mm 1,5 m., incl. hood and wall console



## PERMA arm 2 and 3 joint

PERMA arm is suitable for use in hairdressing salons, dental clinics, jewelers, pharmacies, veterinarians, foot therapists, schools, laboratories / hospitals, slaughterhouse extraction, dairy extraction and extraction in supermarkets. In addition, the suction arm is suitable for the electronics industry (ESD approved) As well as to the chemical, plastics and mechanical industries.

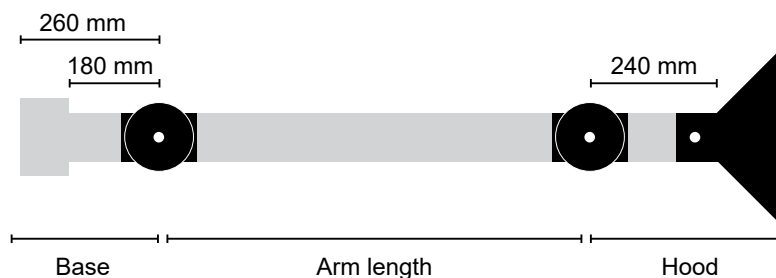

Example: PERMA arm  $\varnothing$ 57 ESD, 580 mm 2 joint  
The 580 mm is from center joint to center joint.



PERMA arm with a white joint

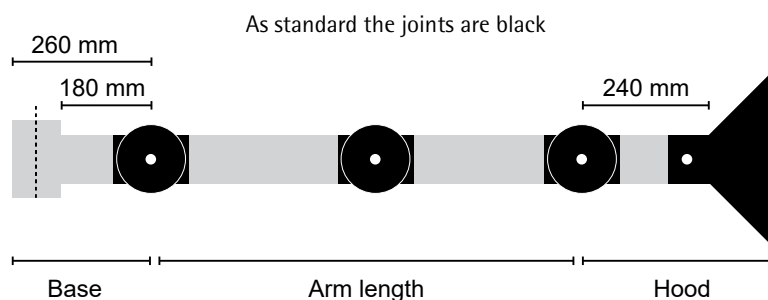

Example: PERMA arm  $\varnothing$ 57 ESD, 1150 mm 3 joint  
The 1150 mm is from center joint to center joint.

### Guide for PERMA arm use:

Sectors	PERMA arm			
	$\varnothing$ 57	$\varnothing$ 57 ESD	$\varnothing$ 76	$\varnothing$ 76 ESD
Dental Technician	x <sup>1</sup>		x <sup>1</sup>	
Veterinarians and clinics			x <sup>2</sup>	
Podiatrists	x <sup>6</sup>			
Nail Clinic	x <sup>1</sup>			
Doctors and specialists	x <sup>1</sup>		x <sup>5</sup>	
Laboratories		x <sup>1 2</sup>	x <sup>1 2</sup>	x <sup>1 2</sup>
Hospitals			x <sup>1</sup>	
Pharmacies			x <sup>2</sup>	
Gold and silversmiths	x <sup>1</sup>		x <sup>2</sup>	
Hairdressing	x <sup>3</sup>			
Classrooms in schools, colleges and universities	x <sup>1</sup>		x <sup>1 4</sup>	
Electronics industry		x <sup>1</sup>		x <sup>1</sup>

- Chemicals:                    1 Extraction arm with flexible hoses and suction tip  
                                      2 Extraction arm with dome or funnel  
                                      3 Extraction arm with flat screen, dome or funnel
- Odour:                            2 Extraction arm with dome or funnel
- Gas, smell:                    4 Extraction arm with suction funnel or dome
- Solder Fume:                   1 Extraction arm with flexible hoses and suction tip
- Anaesthetic Gases:         5 Extraction arm with suction funnel
- Dust:                              1 Extraction arm with flexible hoses and suction tip
- Grinding dust:                6 Extraction arm with suction funnel and hose

# STEP 1.

Choose color and size



## Pressure drop - PERMA arm

Guiding airflow:  
 ø57 mm 50-90 m<sup>3</sup>/h  
 ø76 mm 80-180 m<sup>3</sup>/h

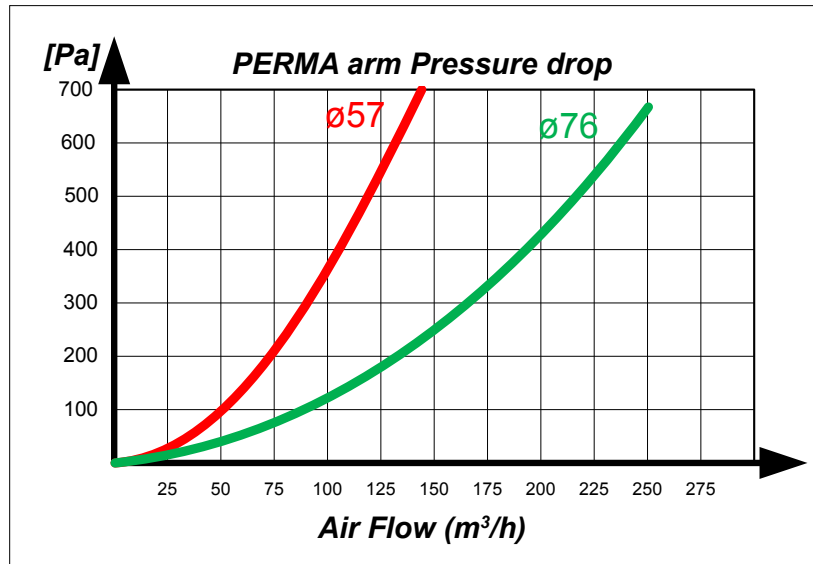

## Working area

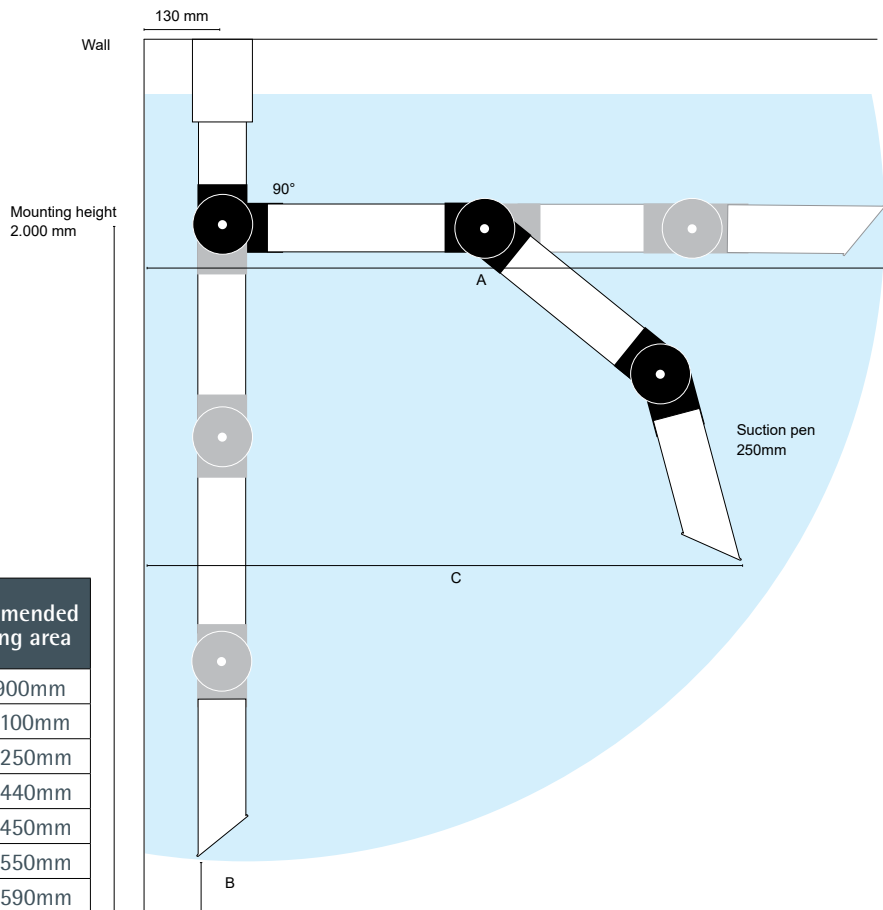

Arm-length	A	B	Recommended working area
750mm	1210mm	900mm	500-900mm
950mm	1410mm	700mm	600-1100mm
1150mm	1610mm	500mm	600-1250mm
1250mm	1710mm	400mm	650-1440mm
1350mm	1810mm	300mm	700-1450mm
1420mm	1880mm	230mm	700-1550mm
1490mm	1950mm	160mm	750-1590mm

PERMA arm, base / mounting bracket

STEP 2.



Art. No	Description
10-315	Base for wall/ceiling L: 180 mm, connection ø100 mm spiro pipe, ø57
10-415	Base for wall/ceiling L: 180 mm, connection ø100 mm spiro pipe, ø76
10-500	Table bracket, install in ø71 mm hole in the table, connection ø63 mm NP, ø57
10-500A	Table bracket, install in ø88 mm hole in the table, connection ø80 mm NP, ø76
10-501	Table bracket, mounted on edge of table, connection ø63 mm NP, ø57
10-501A	Table bracket, mounted on edge of table, connection ø80 mm NP, ø76

PERMA arm, base / mounting bracket - ESD



Art. No	Description
10-365	Base for wall/ceiling L:180 mm, connection ø100 mm spiro pipe, ESD, ø57
10-465	Base for wall/ceiling L: 180 mm, connection ø100 mm spiro pipe, ESD, ø76
10-365B	Table bracket, install in ø71 mm hole in the table, connection ø63 mm NP, ESD, ø57
10-465B	Table bracket, install in ø88 mm hole in the table, connection ø80 mm NP, ESD, ø76
10-365C	Table bracket, mounted on edge of table, connection ø63 mm NP, ESD, ø57
10-465C	Table bracket, mounted on edge of table, connection ø80 mm NP, ESD, ø76

PERMA arm ø57 mm, self carrying arm, 2 or 3 joints

STEP 3.



AS STANDARD  
THE JOINTS ARE BLACK

Art. No. *	Description
10-300H/S	PERMA arm, 380mm 2 joints white or black, ø57
10-301H/S	PERMA arm, 480mm 2 joints, white or black, ø57
10-302H/S	PERMA arm, 580mm 2 joints, white or black, ø57
10-303H/S	PERMA arm, 750mm 3 joints, white or black, ø57
10-304H/S	PERMA arm, 950mm 3 joints, white or black, ø57
10-305H/S	PERMA arm, 1150mm 3 joints, white or black, ø57
10-306H/S	PERMA arm, 1250mm 3 joints, white or black, ø57
10-307H/S	PERMA arm, 1350mm 3 joints, white or black, ø57
10-308H/S	PERMA arm, 1420mm 3 joints, white or black, ø57
10-309H/S	PERMA arm, 1490mm 3 joints, white or black, ø57

All Perma arms are incl. damper.  
\*H=White - S=Black

PERMA arm  $\varnothing$ 76 mm, self carrying arm, 2 or 3 joints

STEP 3.



AS STANDARD  
THE JOINTS ARE BLACK

Art. No. \* Description

10-400H/S	PERMA arm, 380mm 2 joints, white or black, $\varnothing$ 76
10-401H/S	PERMA arm, 480mm 2 joints, white or black, $\varnothing$ 76
10-402H/S	PERMA arm, 580mm 2 joints, white or black, $\varnothing$ 76
10-403H/S	PERMA arm, 750mm 3 joints, white or black, $\varnothing$ 76
10-404H/S	PERMA arm, 950mm 3 joints, white or black, $\varnothing$ 76
10-405H/S	PERMA arm, 1150mm 3 joints, white or black, $\varnothing$ 76
10-406H/S	PERMA arm, 1250mm 3 joints, white or black, $\varnothing$ 76
10-407H/S	PERMA arm, 1350mm 3 joints, white or black, $\varnothing$ 76
10-408H/S	PERMA arm, 1420mm 3 joints, white or black, $\varnothing$ 76
10-409H/S	PERMA arm, 1490mm 3 joints, white or black, $\varnothing$ 76

All Perma arms are incl. damper.  
\*H=White - S=Black

PERMA arm  $\varnothing$ 57mm, self carrying arm, 2 or 3 joints, ESD/antistatic. Only available in black



ONLY IN BLACK

Art. No. Description

10-350	PERMA arm, 380mm 2 joints, ESD, $\varnothing$ 57
10-351	PERMA arm, 480mm 2 joints, ESD, $\varnothing$ 57
10-352	PERMA arm, 580mm 2 joints, ESD, $\varnothing$ 57
10-353	PERMA arm, 750mm 3 joints, ESD, $\varnothing$ 57
10-354	PERMA arm, 950mm 3 joints, ESD, $\varnothing$ 57
10-355	PERMA arm, 1150mm 3 joints, ESD, $\varnothing$ 57
10-356	PERMA arm, 1250mm 3 joints, ESD, $\varnothing$ 57
10-357	PERMA arm, 1350mm 3 joints, ESD, $\varnothing$ 57
10-358	PERMA arm, 1420mm 3 joints, ESD, $\varnothing$ 57
10-359	PERMA arm, 1490mm 3 joints, ESD, $\varnothing$ 57

All Perma arms are incl. damper.

PERMA arm  $\varnothing$ 76 mm, self carrying arm, 2 or 3 joints, ESD/antistatic. Only available in black



ONLY IN BLACK

Art. No. Description

10-450	PERMA arm, 380mm 2 joints, ESD, $\varnothing$ 76
10-451	PERMA arm, 480mm 2 joints, ESD, $\varnothing$ 76
10-452	PERMA arm, 580mm 2 joints, ESD, $\varnothing$ 76
10-453	PERMA arm, 750mm 3 joints, ESD, $\varnothing$ 76
10-454	PERMA arm, 950mm 3 joints, ESD, $\varnothing$ 76
10-455	PERMA arm, 1150mm 3 joints, ESD, $\varnothing$ 76
10-456	PERMA arm, 1250mm 3 joints, ESD, $\varnothing$ 76
10-457	PERMA arm, 1350mm 3 joints, ESD, $\varnothing$ 76
10-458	PERMA arm, 1420mm 3 joints, ESD, $\varnothing$ 76
10-459	PERMA arm, 1490mm 3 joints, ESD, $\varnothing$ 76

All Perma arms are incl. damper.

STEP 4.



Art. No. Description

10-316	Hood ø380 mm, polycarbonate, ø57
10-416	Hood ø380 mm, polycarbonate, ø76
10-317	Hood conical ø250 mm, polycarbonate, ø57
10-417	Hood conical ø250 mm, polycarbonate, ø76
10-318	Hood conical ø250 mm, polycarbonate, with flextube 300 mm, ø57
10-418	Hood conical ø250 mm, polycarbonate, with flextube 300 mm, ø76
10-319	Hood conical ø250 mm, polycarbonate, straight edge, ø57
10-419	Hood conical ø250 mm, polycarbonate, straight edge, ø76
10-320	Hood conical ø250 mm, polycarbonate, with flextube 300 mm, straight edge, ø57
10-420	Hood conical ø250 mm, polycarbonate, with flextube 300 mm, straight edge, ø76
10-321	Aluminium hood conical ø150 mm, ø57
10-421	Aluminium hood conical ø150 mm, ø76
10-366	Aluminium hood conical ø150 mm, ESD, ø57
10-466	Aluminium hood conical ø150 mm, ESD, ø76
10-323	Hood 340x250 mm, polycarbonate, ø57
10-425	Hood 340x250 mm, polycarbonate, ø76
10-324	Suction pen L: 250 mm, ALU, ø57
10-422	Suction pen L: 250 mm, ALU, ø76
10-367	Suction pen L: 250 mm, ALU, ESD, ø57
10-467	Suction pen L: 250 mm, ALU, ESD, ø76
10-325	Suction pen L: 350 mm, ALU, ø57
10-423	Suction pen L: 350 mm, ALU, ø76
10-368	Suction pen L: 350 mm, ALU, ESD, ø57
10-468	Suction pen L: 350 mm, ALU, ESD, ø76
10-324A	Suction pen L: 250 mm, press flange, ALU, ø57
10-422A	Suction pen L: 250 mm, press flange, ALU, ø76
10-367A	Suction pen L: 250 mm, press flange, ALU, ESD, ø57
10-467A	Suction pen L: 250 mm, press flange, ALU, ESD, ø76

Tube 180 mm connecting the hood with the arm are included



## Extraction hoods and suction pen

### STEP 4.



#### Art. No. Description

10-325A	Suction pen L: 350 mm, press flange ALU, ø57
10-423A	Suction pen L: 350 mm, press flange ALU, ø76
10-368A	Suction pen L: 350 mm, press flange ALU, ESD, ø57
10-468A	Suction pen L: 350 mm, press flange ALU, ESD, ø76
10-326	Suction pen L: 150 mm with flextube 300 mm, ALU, ø57
10-424	Suction pen L: 150 mm with flextube 300 mm, ALU, ø76
10-369	Suction pen L: 150 mm with flextube 300 mm, ALU, ESD, ø57
10-469	Suction pen L: 150 mm with flextube 300 mm, ALU, ESD, ø76
10-326A	Suction pen press flange L: 150 mm with flextube 300 mm, ALU, ø57
10-424A	Suction pen press flange L: 150 mm with flextube 300 mm, ALU, ø76
10-369A	Suction pen press flange L: 150 mm with flextube 300 mm, ALU, ESD, ø57
10-469A	Suction pen press flange L: 150 mm with flextube 300 mm, ALU, ESD, ø76
10-370	Suction pen L: 150 mm with flextube 600 mm, 1-joint, with damper, ALU, ø57
10-371	Suction pen L: 150 mm with flextube 600 mm, with damper, ALU, ø57
10-329	Hood oval 140x180 mm, polycarbonate, ø57
10-382	Hood oval 140x180 mm, polycarbonate, ESD, ø57
10-374	Hood ø380 mm, painted polycarbonate, ESD, ø57
10-470	Hood ø380 mm, painted polycarbonate, ESD, ø76
10-375	Hood conical, ø250 mm, painted polycarbonate, ESD, ø57
10-471	Hood conical, ø250 mm, painted polycarbonate, ESD, ø76
10-377	Hood conical, straight edge, ø250 mm, painted polycarbonate, ESD, ø57
10-473	Hood conical, straight edge, ø250 mm, painted polycarbonate, ESD, ø76
10-380	Hood 340x250 mm, painted polycarbonate, ESD, ø57
10-475	Hood 340x250 mm, painted polycarbonate, ESD, ø76
10-476	Oval light kit, LED, incl. trafo
10-477	Kontaksæt for LED Lyssæt

Tube 180 mm connecting the hood with the arm are included

STEP 5.



Art. No.	Description
10-502	Ceiling console, with side connection, 250 mm
10-503	Ceiling console, with side connection, 350 mm
10-504	Ceiling console, with side connection, 500 mm
10-505	Ceiling console, with side connection, 750 mm
10-506	Ceiling console, with side connection, 1000 mm
10-507	Pipe white ø100 - 500 mm
10-508	Pipe white ø100 - 1000 mm
10-509	Wall bracket for pipe, 75 mm from the wall
10-510	Ceiling bracket closed ø100 mm - 200x200 mm
10-511	Ceiling bracket open ø100 mm - 200x200 mm
10-512	Branch pipe ø100 mm, 620x250 mm - used for 1 outlet and 2 arms
10-514	Support bracket for ceiling pipes
We recommend that all arms and hoods are cleaned with water	



# OIL MIST FILTERS



## GFO 315 Filter

The Geovent GFO 315 filter is used for filtration of oil mists from CNC lathes, cutting and drilling machinery etc., and has a capacity of up to 1.000 m<sup>3</sup>/h and up to 99% separation degree.

The filter is easy to install and service, and is equipped with a drain tap for recycling of collected oil.

The filter cartridge consist of a polyester filter membrane, which tolerates both oil and water-based mists and smoke.

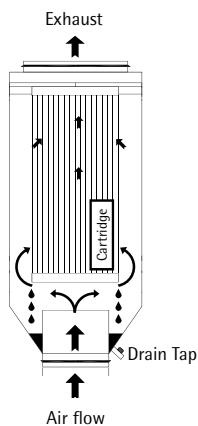

GEOVENT oil mist filters are available in different versions to suit different needs.

The smaller Geofilter Oil covers cutting machines up to 600 m<sup>3</sup>/h.

GFO XT has a capacity of up to 10.000 m<sup>3</sup>/h per unit.

The filters can be connected in parallel for filtration of larger air flows.

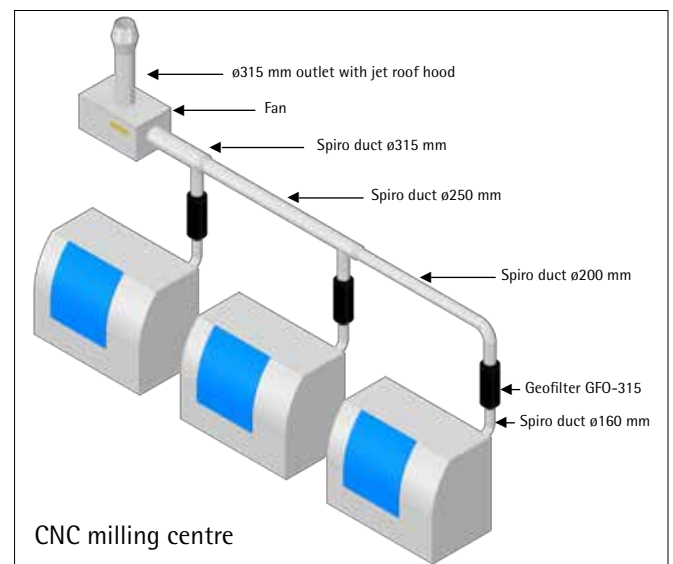



# FILTERS



## Customized oil filter solution

In cooperation with the customer and the installer, Geovent designed a solution for filtration of oil mist from a melting process. The oil mist also contains particles of soot, which complicates the filtration. The solution is based on standard products and takes place in 3 steps for optimized separation and long service life.



Motorized height adjustable hood (customized solution), mounted on standard extension arm.

# DUST FILTERS



GEOVENT filters are used in a number of different processes, such as filtering welding smoke and various kinds of dust. Our filters meet the increasingly strict requirements and ensure a healthy working environment.

With our series of compressed air cleaning cartridge filters, we can handle most filtering tasks - including ATEX.

With an effective filtration of the extracted air, heat recovery is possible. By recovering heat from the extracted air, the energy use is minimized, and therefore contributes to a reduction in CO<sub>2</sub> consumption.





# FILTERS



Project with 2 complete filter systems and pressure controlled fans.



GFB2 filter customized design with isolation and painted gray.

## GeoFilter Oil – oil mist filtration



### Art. No. Description

15-020	GeoFilter Oil 100 400x400 – up to 95% filtration. Max. airflow: 400 m <sup>3</sup> /h. Initial pressure drop: 100 Pa v. 400 m <sup>3</sup> /h.
15-220	GeoFilter Oil 160 400x600 – up to 95% filtration. Max. airflow: 600 m <sup>3</sup> /h. Initial pressure drop: 150 Pa v. 600 m <sup>3</sup> /h.
15-030	Aluminium filter mat 400x400
15-031	Aluminium filter mat 400x600

## GFO 315 – 99% oil mist filtration



### Art. No. Description

15-320	GFO-315 - up to 99% oil mist filtration. Max airflow: 800 m <sup>3</sup> /h. Inlet =ø200 mm, outlet = ø315 mm
15-335	Filter cartridge for GFO filter
15-338	Filterwrap for 15-335. Acts as prefilter for the filter cartridge, so it is charged less. An efficient and cheap solution, recommended for heavy load processes.
15-321	GFO-315- EXT - up to 99% oil mist filtration. Max airflow: 1.000 m <sup>3</sup> /h. Inlet =ø200 mm, outlet = ø315 mm Extended filter, for increased filter load
15-336	Filter cartridge for GFO filter, extended cartridge
15-339	Filterwrap for 15-336. Acts as prefilter for the filter cartridge, so it is charged less. An efficient and cheap solution, recommended for heavy load processes.

## GFO XT – for oil mist filtration at several work stations



GFO XT – up to 99% oil mist filtration. The filter is used as zone filter for large processing centers, for example, or as central filter for several lathers/cutters etc. The filter is equipped with polypropylene filter cartridges. Recommended end pressure drop = 1.200 Pa. Reservoir with drain tap and sight glass for oil level control. Normal load should be less than max. load.

Art. No.	Description	Filter area	Max m <sup>3</sup> /h
15-353	GFO XT-3	14,7 m <sup>2</sup>	2.400
15-354	GFO XT-6	29,4 m <sup>2</sup>	4.800
15-355	GFO XT-9	44,1 m <sup>2</sup>	7.200
15-356	GFO XT-12	58,8 m <sup>2</sup>	9.600

### Example of installation GeoFilter Oil

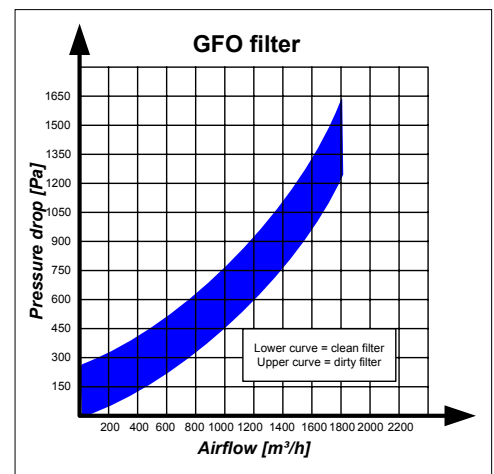
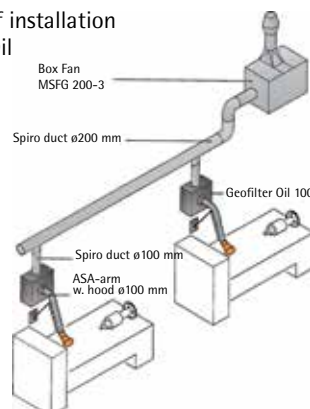

## GeoFilter GF4

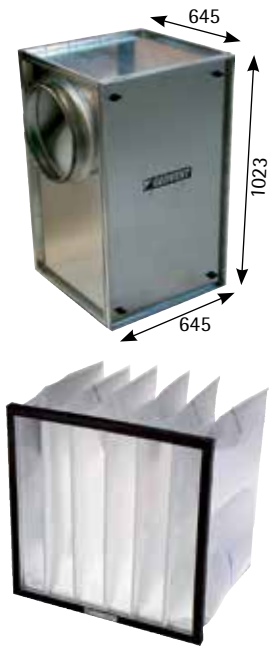

### Art. No. Description

The GF4 filter is designed for smaller concentrations of dust. Filtration up to 99%, dep. on filter type. Max. airflow: 4.000 m<sup>3</sup>.

15-504	GeoFilter GF4-1 EU3 86% filtration at 0,3 µm – ø400 mm
15-503	GeoFilter GF4-2 EU5 95% filtration at 0,3 µm – ø400 mm
15-502	GeoFilter GF4-3 EU9 >99% filtration at 0,3 µm – ø400 mm

15-516	Filter G35 1/1 EU3 595x595x330 – 86% filtration*
15-517	Filter G50 1/1 EU5 595x595x650 – 95% filtration*
15-518	Filter G95 1/1 EU9 595x595x650 – >99% filtration*
15-519	Active coal filter f/GF4 F9 filter added active coal
15-520	HEPA-filter H13 f/GF4

\*According to DIN24185

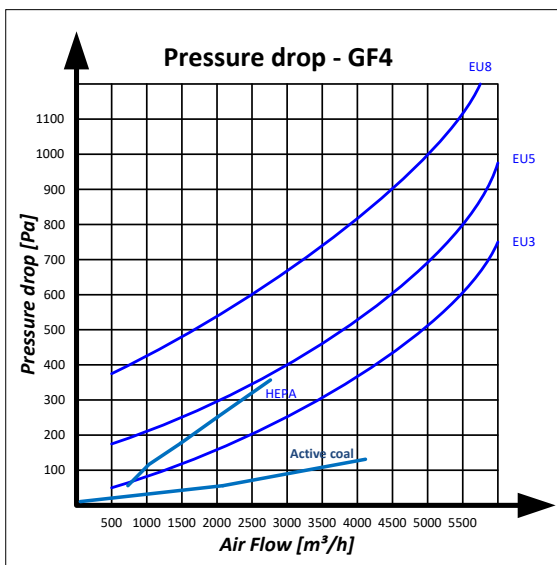

### Installation example GeoFilter Dust

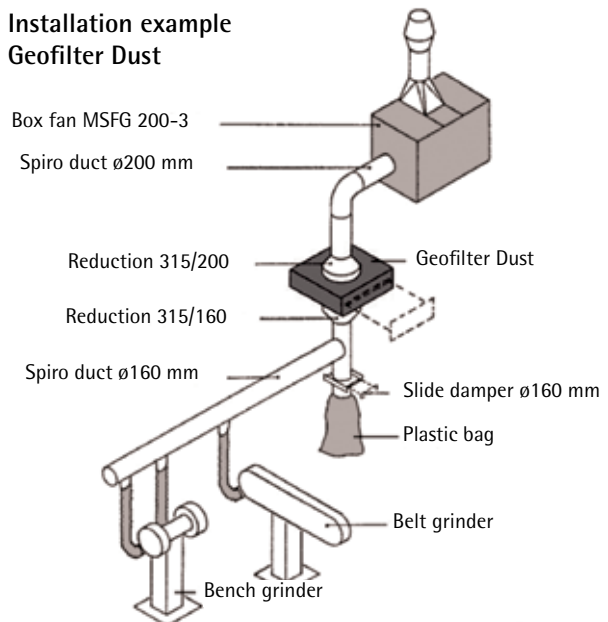

## GeoFilter Dust



15-322 GeoFilter GF 315

### Art. No. Description

15-051	GeoFilter Dust with 500 x 500 mm EU3 surface filter (85% filtration at 0,3µm). Start pressure drop 55 Pa v. 1.500 m <sup>3</sup> /h. Max. airflow: 1.500 m <sup>3</sup> /h. Connection ø315 mm NP
--------	---

15-035	Replacement filter EU5 (95% filtration v. 0,3µm) 500x500 mm for GeoFilter Dust
15-036	Replacement filter EU3 (85% filtration v. 0,3µm) 500x500 mm for GeoFilter Dust

56-074	Reduction MF315/NP160 mm for GeoFilter Dust
56-075	Reduction MF315/NP200 mm for GeoFilter Dust

15-322	GeoFilter GF 315. Patron filter for smoke/dust. 18m <sup>2</sup> – without cleaning system. Inlet/outlet = ø200 mm. H: 800 mm – ø400 mm. Air Flow: 800 – 1.500 m <sup>3</sup> /h. With snap flanges for easy service access.
--------	--

## Dustbox CFU-1000



Dustbox with fan and manual compressed air cleaning.



### Art. No. Description

The Dustbox CFU-1000 is a compact filter unit, well suited for extraction of particles from grinding processes and more. 10 m<sup>2</sup> polyester filter cartridge, filtration efficiency 99,9% at 0,3µm. H: 880 mm, W: 500 mm, D: 500 mm. Inlet/outlet: 160 mm NP

- Max. airflow: 1.500 m<sup>3</sup>/h, recommended 1.000 m<sup>3</sup>/h.
- Well suited for grinding dust, welding smoke and more.
- Recommended end pressure drop before cartridge replacement: Max 1.800 Pa
- The ideal filter for smaller filtration needs with high demands for filtration efficiency.

15-100	Dustbox CFU-1000, ex. fan
15-101	Fan for Dustbox CFU-1000 with enclosed B-impeller, 1,1kW, 3x400V, 50Hz, 2800 rpm
15-102	Soundproofing for Dustbox CFU-1000
15-103	Automatic control for Dustbox CFU-1000 (motor guard, pressure guard and more)
15-104	Manual compressed air cleaning, CFU-1000
15-105	Automatic compressed air cleaning, CFU-1000
15-108	Filter cartridge for CFU-1000

## GeoFilter GFB2 - 99,9% filtration at 0,3µm



### Art. No. Description Filter area Max m<sup>3</sup>/h

15-460	GeoFilter GFB2-3-1	30 m <sup>2</sup>	1.800
15-461	GeoFilter GFB2-6-2	60 m <sup>2</sup>	3.600
15-462	GeoFilter GFB2-9-3	90 m <sup>2</sup>	5.400
15-463	GeoFilter GFB2-12-4	120 m <sup>2</sup>	7.200

All GFB2-filters are by default fitted with cartridges FT/11. Other cartridge types available, see below.

## GeoFilter GFB HD - 99,9% filtration at 0,3µm



### Art. No. Description Filter area Max m<sup>3</sup>/h

15-400-HD	GeoFilter GFB-3-1 HD	30 m <sup>2</sup>	1.050
15-401-HD	GeoFilter GFB-6-2 HD	60 m <sup>2</sup>	2.100
15-402-HD	GeoFilter GFB-9-3 HD	90 m <sup>2</sup>	3.150
15-403-HD	GeoFilter GFB-12-4 HD	120 m <sup>2</sup>	4.400

By default supplied with 1,5" shot valves for improved cleaning at heavy load and PTFE coated filter cartridges (FT/18) for easier dust release.

By default supplied with timer control. Pressure control available on request.

## Replacement cartridges for GFB and GFB2 - Filterarea pr. cartridge: 10m<sup>2</sup>



Filter cartridges are selected according to the kind of dust that needs separation. All GFB and GFB2-filters are by default fitted with cartridge FT/11 for dust filled air without smoke or oil mists. See page 52 for selection of correct filter cartridge. When ordering, indicate whether the unit is top- or front operated.

Art. No.	Description
15-480FL	FT/11 - 99,9% v/0,3µm (grinding dust / All-Round)
15-480AFL	FT/11 - 99,9% v/0,3µm ALUTEC (All-Round)
15-481FL	FT/13 - 99,9% v/0,3µm (welding smoke)
15-482FL	FT/18 - 99,9% v/0,3µm (laser/plasma) PTFE (for GFB HD)
	Additional charge for alu-coating - pr. filter cartridge.
15-479	Pre-coat - ensures longer service life. Pr. kg. (App. 50 g. pr. cartridge)

## Accessories for GeoFilter GFB2

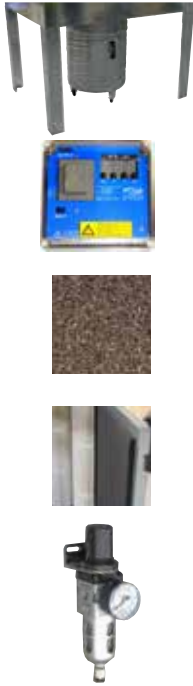

Art. No.	Description
15-440	For large amounts of dust: Bucket w. wheels (54l) and extended legs on filter (new height: 2432 mm).
92-214	Timer control panel GFB2 (mounted as standard)
92-214B	Differential pressure control panel GFB2
15-430	Sound insulation of GFB2 3-1
15-431	Sound insulation of GFB2 6-2
15-432	Sound insulation of GFB2 9-3
15-433	Sound insulation of GFB2 12-4
15-434	Thermal insulation of GFB2 3-1
15-435	Thermal insulation of GFB2 6-2
15-436	Thermal insulation of GFB2 9-3
15-437	Thermal insulation of GFB2 12-4
15-490	Water separator for GFB2 filter with regulator, manometer and mounting bracket.

## Data for GeoFilter GFB2

Model/Dimension [mm]	A	B	C	D	E	H	Inlet	Outlet	Weight	Cabinet
GFB2-3-1	775	935	1830	335	-	2035	ø250np	1xø250np	90 kg.	Hot galv.
GFB2-6-2	810	935	1830	635	-	2035	ø315np	1x315np	135 kg.	Hot galv.
GFB2-9-3	855	935	1830	935	450	2035	ø400np	2x315np	180 kg.	Hot galv.
GFB2-12-4	900	1230	1830	935	373	2035	ø500np	3x315np	225 kg.	Hot galv.

We recommend 500 mm open space on top of the filter for maintenance

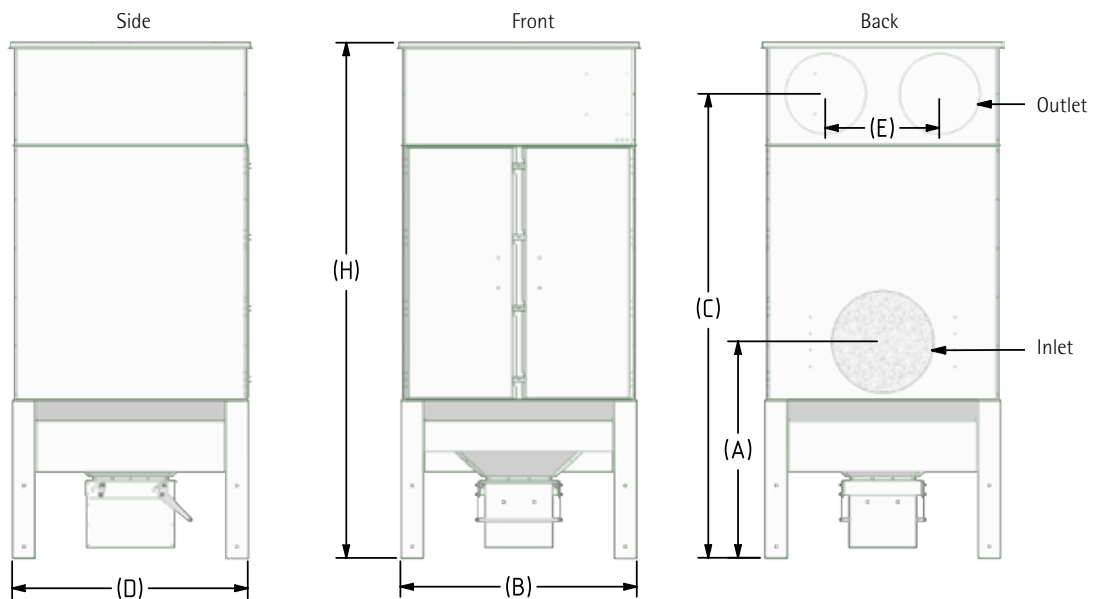

Pressurized air	Air consumption	Power supply	Temperature	Pressure drop	Noise emission	Pipe class
3 - 6 bar* clean and dry air	3,0 liter/min per valve	24V DC or 230V AC	-12°C - +65°C	1000-1500 Pa	<68 dB(A)	Class C

\*Depending on the processes



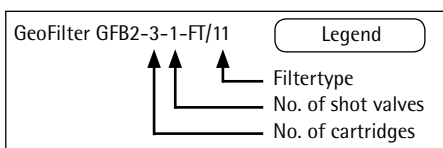
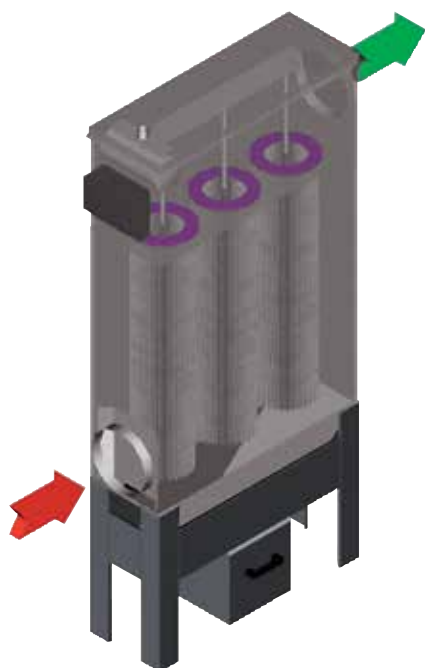

### FILTER CARTIDGES

GeoFilter GFB2 comes with filter cartridges of pleated textiles, with or without coating. (minimum filtering of 99,90% according to IFA-test (DIN EN 60335-2-69))

### FILTER CLEANING

The cleaing of the filter is automatically carried out with a shot of compressed air through the cartridges. This will cause the particles caught in the textile to fall in to the collection bucket below for disposal.

### FILTER REPLACEMENT

Dismantle the front cover and twist the cartridges out from the bayonet mount.

### INSTALLATION

Generally the filter should be placed indoors to avoid condensation. However, if needed, the filter can be placed outside on account of the fully galvanized housing. The filter requires a power supply of 230V AC and 3 - 6 bar clean and dry compressed air. The filter should not be used with a differential pressure higher than 3000 Pa.

### FILTER AUTOMATICS

The GFB2 filter comes with a user friendly filter control panel with digital display. Adjust the shot length (0-9 sek.), shot interval (1-999 sec.) and after-run cycle (1-9 cycle). Connects to 230 V AC 50 Hz. For differential pressure control use 92-214B.

## Geovent filter media use

Application	Art. No.	15-335	15-480 FL	15-108 Dustbox	15-482	03-260 HVU	03-259 HVU	03-260 HVU-it	15-480A	15-481FL	15-483FL
Oil Mist		X									
Dry welding smoke										X	
Oil saturated welding smoke										P*	
Foundry										X	
Zink						X	X	X			X
Powder Coating			X						X		
Plasma/laser cutting					P*						
Sand blasting / Sand			X								
Sand blasting/ Glas									F*		
Sand blasting / enamel, steel, aluminium						X	X	X			
Grinding				X		X	X	X		X	
Unspecified dust without smoke			X								
Milk powder											X
Spice											A*
Tobacco											A*
Paper									X		
Chalk										X	
Cement										X	
Wood dust									A*		

\*Notes: P = Prekote F = Moisture resistant A = ATEX approved

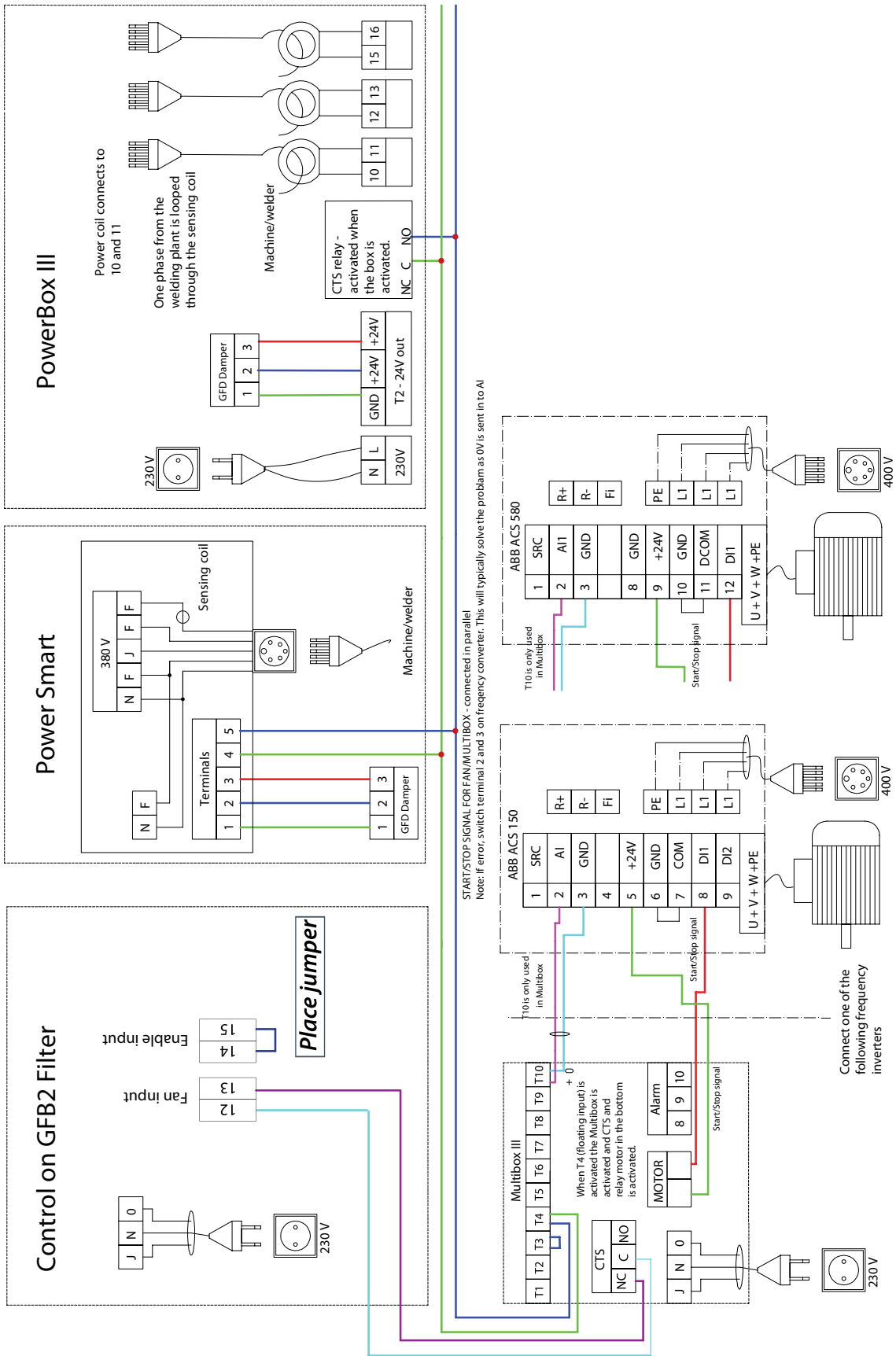

**Adjusting Multibox III:**  
 Quickguide - also see manual  
 P0: Version selector - select 530 (most common)  
 P1: Adjustment set point [Pa]  
 P2: Min. Alarm limits [s] at too low pressure  
 P3: Max. Alarm limit [s] at too high pressure  
 P10: Shows current pressure.

**OBS - IMPORTANT - ACS 150**  
 Jumper on the bottom (SI) must be switched from "I" to "U" This will change output from current to voltage.  
 Remember to bridge GND and COM.

**Adjusting frequency inverter:**  
 See manual - important parameters to adjust:

**Motordata:** Typically parameter group 99  
**Ramp up/down:** Typically parameter group 22  
**Frequency Max/Min:** Typically parameter group 20 and 11

# GFB2 TOWER

GeoFilter GFB2 Tower is a all in one, self-cleaning cartridge filter solution, with a built-in fan on top. The GFB2 Tower is based on our popular GFB2 filter and high efficient MEF fans with B-type impellers. Complete solution, ready to connect to power and compressed air. The construction is made of robust galvanized sheet metal, easy access to filter change through the front hatch, and emptying of the bin, is swiftly done, by releasing the handle on the bin. Compressed air tank is built into the clean side of the filter, and the unit is supplied with a TIMER controller as standard. A wide selection of filter material is available, and should always be selected to match the specific process.

Differential pressure control, frequency inverter and insulation can be offered.

Airflow capacity of up to 7.200 m<sup>3</sup>/h.

We normally recommend placing the filter indoor. Outdoors placing can result in condensation issues.

If the filter is placed outside, however, we suggest using a protective roof/shed to shield the filter from rain.

Filter cartridges come in a wide variety of pleated fabric, custom fitted to the specific process.

As standard, the GFB2 Tower is supplied with filter cartridge FT/11 for dust (dry air without fumes or oil mist).

See also range of available standard filter media.



Model	GFB2 Tower 6-2	GFB2 Tower 9-3	GFB2 Tower 12-4
Number of filter cartridges	6	9	12
Filter type	Standard	Standard	Standard
Filter area [m <sup>2</sup> ]	60	90	120
Number of shot valves	2	3	4
Max Airflow [m <sup>3</sup> /h] (Dependant on volume)	3600	5400	7200
Air tank [liter]	8	12	16
Filter control w. display, Protection class	IP65	IP65	IP65
Inlet/outlet, sealing class	Classe C	Classe C	Classe C
Collection bucket [liter]	25	25	25
Galvanized cabinet, Corrosion class	III	III	III
Order number	15-471	15-472	15-473
Fan	MEF 400-3, 4,0 kw / 5,5 kw	MEF 450-3, 5,5 kw / 7,5 kw	MEF 500-3, 7,5 kw

## GFB2 Tower



Art. No.	Description	Filter area	Max m <sup>3</sup> /h
15-471	GeoFilter GFB2 Tower 6-2 incl. MEF 400-3	60 m <sup>2</sup>	3600
15-472	GeoFilter GFB2 Tower 9-3 incl. MEF 450-3	90 m <sup>2</sup>	5400
15-473	GeoFilter GFB2 Tower 12-4 incl. MEF 500-3	120 m <sup>2</sup>	7200

Pressurised air	Air usage	Power supply	Temperature	Typical pressure drop	Sound level
3 - 6 bar clean and dry air	3,0 l/min pr. valve	24VDC or 230 VAC	-12° - +65° C	1000-1500 Pa	<68 dB(A)

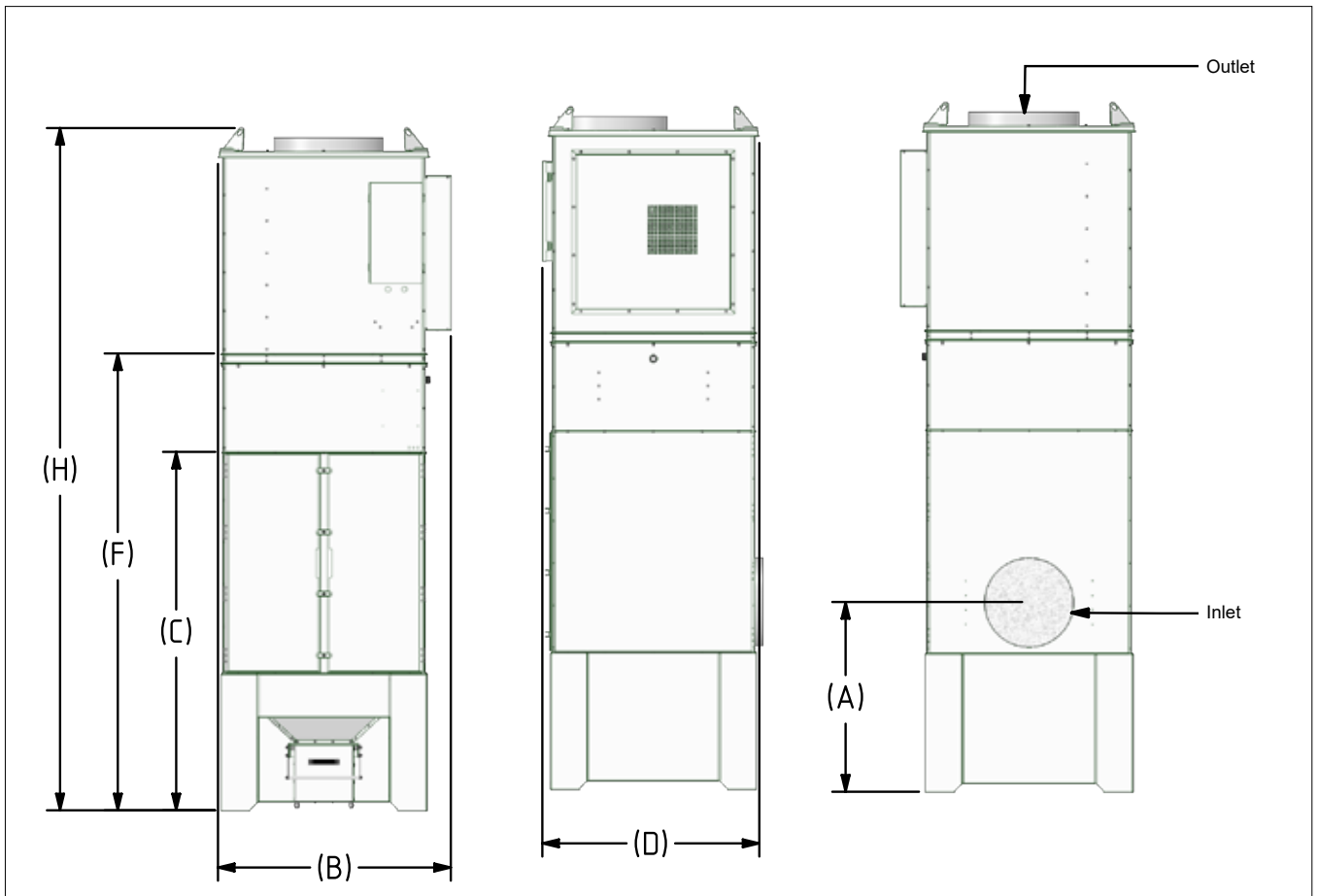

Model/Dimensions [mm]	A	B	C	D	F	H	Inlet	Outlet	Weight	Cabinet
GFB2 Tower 6-2	810	985	1630	910	2080	3040	ø315np	ø400np	kg	Hot galvanized
GFB2 Tower 9-3	855	1060	1630	985	2080	3100	ø400np	ø500np	360 kg	Hot galvanized
GFB2 Tower 12-4	900	1230	1630	985	2080	3150	ø500np	ø500np	kg	Hot galvanized

# FANS

GEOVENT offers a wide range of fans with air flow up to 55.000 m<sup>3</sup>/h. Further we can provide fans up to 4.800 Pa and can deliver fans to almost every task.

- Fans are available as central and decentral fans
- Mobile, portable fans
- Energy saving fans
- Two-speed motor
- Motor with 6- and 8-poles
- With frequency inverter
- High temperature fans
- Stainless or plastic
- ATEX version

At Geovent we are ready to do our best to help you with your ventilation project.

We produce the fans ourselves on the Geovent factory in Løgstrup, where we also keep a stock of intermediate goods such as fan housings, motors and wheels.

This means we offer high flexibility and fast delivery. Most of our fans are made of galvanized steel to last for a long period.





# FANS



GEOVENT centrifugal fans LSFG/MSFG (with forward curved blades) and LEF/MEF (with backwards curved blades) are used for process extraction in industry or for comfort ventilation.

The fans LEF/MEF has a high efficiency of up to 87% and is suitable for PID / constant pressure control. The fan is made of 100% galvanized steel for maximum corrosion resistance and therefore suitable for outdoor installation on a roof or wall.

Our fans can be placed in a sound box to reduce noise emission.

Some of the advantages of backward curved blades:

- Efficiency of up to 87%
- Well suited for pressure control causing for substantial savings on operation.

Full range of accessories, such as flex connectors, mounting brackets, rain cover, motor protection, pressure gauge and sound box are available in the model program.

As standard included feet with vibration dampers, inlet connection with net, and fixtures for mounting of outlet flange.

The fans can also be delivered in ATEX design according to 2014/34 / EU Directive. In this case, the type is LSX / MSX and comes as standard with EExe motor, see ATEX.

Note: Most models are available in ATEX versions.

Other variations, can be offered on request.

The fan can be delivered in stainless steel (ANSI 316L), with (built-in) frequency converter, two-speed motor, 6- and 8-pole motor, special-voltage motors or higher efficiency, special high temperature version ect.

Air volumes up to 55.100 m<sup>3</sup>/h

Pressure up to 4.800 Pa

Electrical data / Additional data / Features

Motor: Direct drive B5 or B35 flange motor protection class IP-55.

A SIROCCO impeller (forward curved blades) is low noise, low vibration, delivers a high output per kW and provides a relatively high pressure.

Due to the relatively flat curve of the SIROCCO impeller it is not recommended for pressure regulation.



## Fans LSFG/MSFG 146 to 250

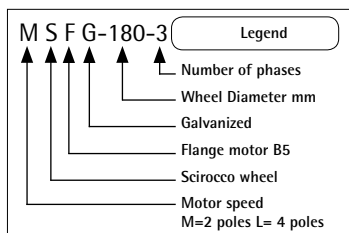

Art. No.	Description	[kW]	[A]	Max [m <sup>3</sup> /h]	Max [Pa]
38-001	LSFG-146-3	0,25	0,8	700	160
38-002	MSFG-146-3	0,55	1,4	900	620
38-005	LSFG-146-1	0,25	2,05	700	160
38-006	MSFG-146-1	0,55	3,57	900	620

30-001	LSFG-180-3	0,25	0,8	1.175	230
30-002	MSFG-180-3	0,55	1,4	1.670	950
30-005	LSFG-180-1	0,25	2,05	1.175	230
30-006	MSFG-180-1	0,55	3,57	1.670	950

31-001	LSFG-200-3	0,55	1,5	1.750	320
31-002	MSFG-200-3	1,1	2,4	2.100	1.450
31-005	LSFG-200-1	0,55	3,83	1.750	320
31-006	MSFG-200-1	1,1	6,5	2.100	1.450

32-001	LSFG-225-3	1,5	3,45	2.500	450
32-002	MSFG-225-3	2,2	4,4	2.950	1.500
32-005	LSFG-225-1	1,5	9,5	2.500	450
32-006	MSFG-225-1	2,2	13,2	2.950	1.500

33-001	LSFG-250-3	2,2	4,6	3.150	470
33-002	MSFG-250-3	4	7,2	4.900	1.840

Motor configurations - please ask

## Pressure drop for fans LSFG/MSFG 146 - 250

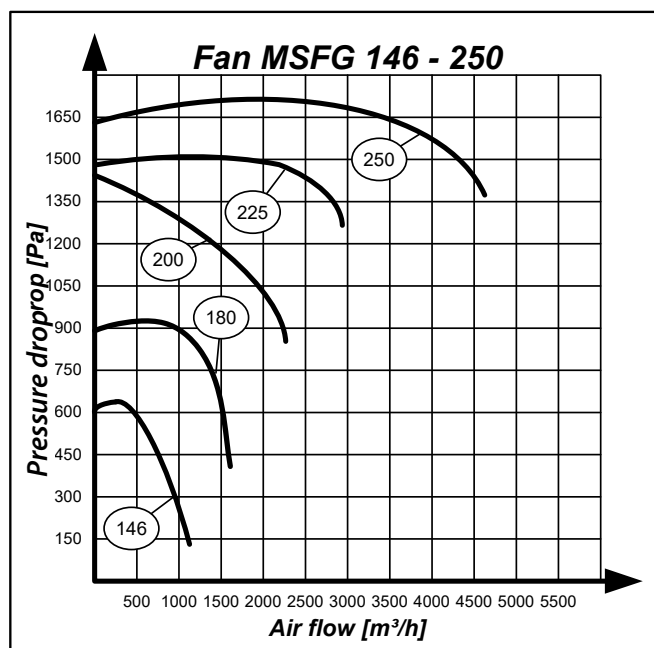
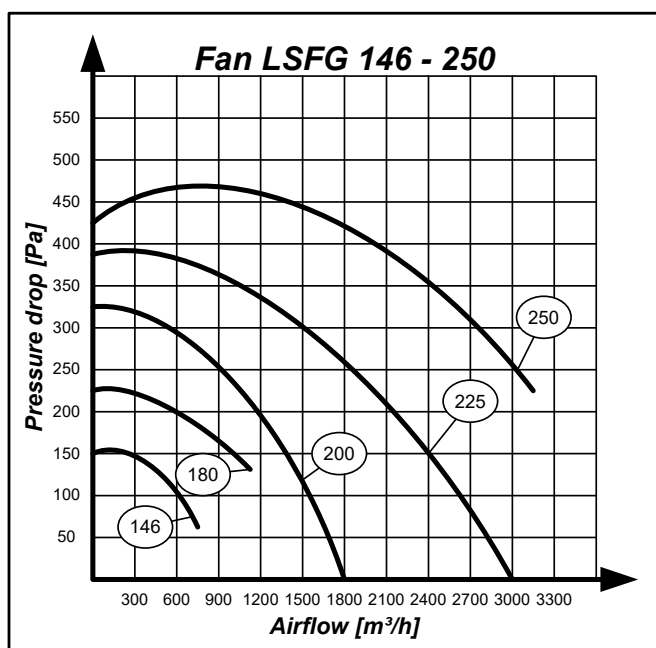

## Sounddata for fans LSG/MSFG 146 - 250

Noise emission																			
Type	125 Hz	250 Hz	500 Hz	1000 Hz	2000 Hz	4000 Hz	8000 Hz	Lp, dB(A)	Lp, 1m	Type	125 Hz	250 Hz	500 Hz	1000 Hz	2000 Hz	4000 Hz	8000 Hz	Lp, dB(A)	Lp, 1m
LSFG 146	46	47	48	46	45	41	35	51	45	MSFG 146	61	62	65	63	64	58	51	69	63
LSFG 180	54	57	53	50	47	42	36	56	50	MSFG 180	70	80	69	64	65	59	54	74	68
LSFG 200	61	62	58	57	50	45	40	61	55	MSFG 200	80	83	72	71	71	66	61	78	72
LSFG 225	62	63	59	58	54	51	45	63	57	MSFG 225	82	85	75	73	74	68	63	81	75
LSFG 250	66	67	64	63	60	54	46	67	61	MSFG 250	86	90	77	75	76	71	65	84	78

## Dimensions, fans LSG/MSFG 146 - 250 and LSX/MSX 146 - 250

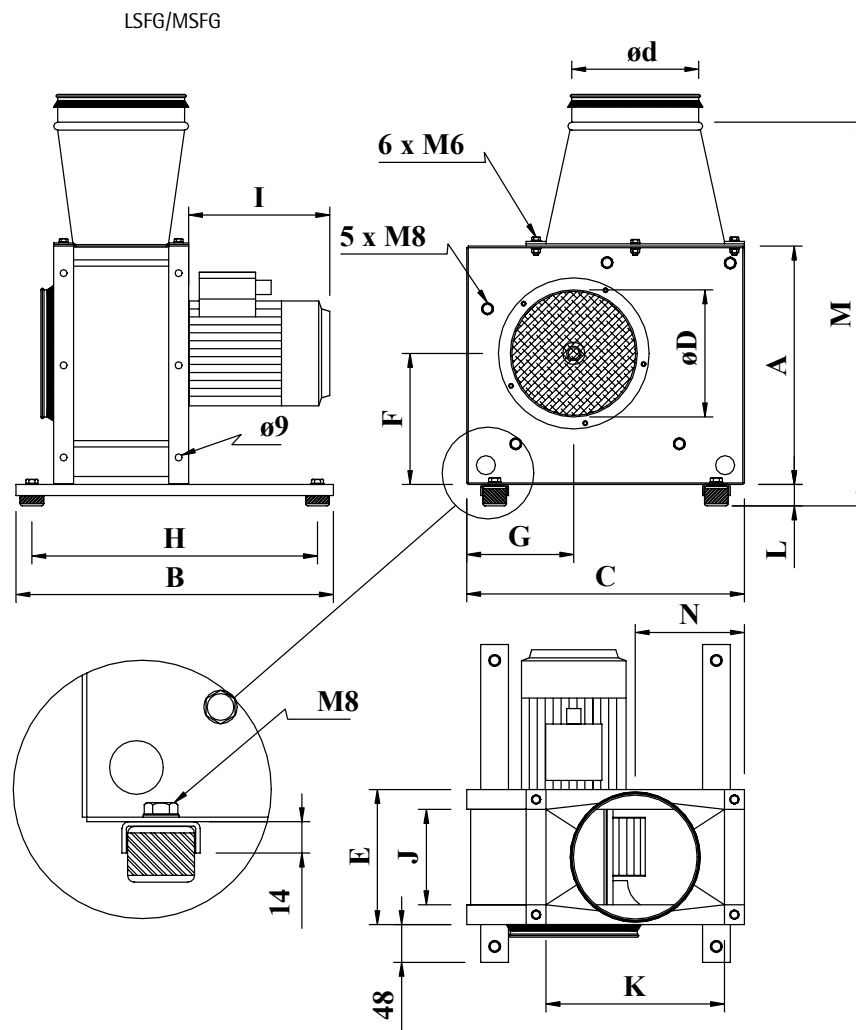

Dimensions, fans LSG/MSFG 146 - 250																
Type	A	B	C	øD	ød	E	F	G	H	I**	J	K	L	M	N	Weight**
L-/MSFG 146	245	400	295	160	*	145	134	113	360	178	95	185	27	402	118	12 kg
L-/MSFG 180	300	400	350	160	*	168	165	135	360	178	120	225	27	527	138	14 kg
L-/MSFG 200	350	400	400	200	*	180	205	165	360	205	130	250	27	577	150	18 kg
L-/MSFG 225	370	500	450	250	*	195	210	190	460	219	145	280	27	597	165	24 kg
L-/MSFG 250	410	500	500	250	*	215	230	210	460	300	170	320	27	637	185	38 kg

\* depending on outlet flange \*\* depending on motor

Fans LEF/MEF 250 to 400 – B-impeller, efficiency up to 87%



Incl. inlet with safety mesh and carrying feet with anti-vibration pads



B-impeller with backward curved blades.

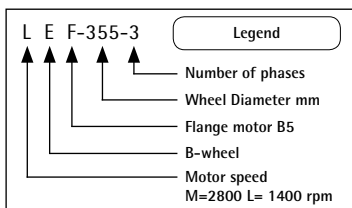

Art. No.	Description	[kW]	[A]	Max[m <sup>3</sup> /h]	Max [Pa]
33-701	LEF-250-3	0,25	0,8	700	230
33-702	MEF-250-3*	0,37	0,95	1.650	1.200
33-703	MEF-250-3*	0,55	1,4	1.900	1.575
33-704	LEF-250-1	0,25	2,05	700	230
33-705	MEF-250-1	0,37	2,73	1.400	825
34-651	LEF-315-3*	0,25	0,8	1.450	360
34-652	MEF-315-3*	0,55	1,4	2.600	1.070
34-653	MEF-315-3	0,75	1,9	2.850	1.330
34-654	MEF-315-3*	1,1	2,4	3.200	1.640
34-655	LEF-315-1	0,25	2,05	1.450	360
34-656	MEF-315-1	0,75	4,9	2.850	1.330
34-701	LEF-355-3	0,25	0,8	2.250	425
34-702	MEF-355-3*	0,75	1,9	3.350	1.000
34-703	MEF-355-3*	1,1	2,4	3.800	1.240
34-704	MEF-355-3	1,5	3,15	4.350	1.550
34-705	MEF-355-3*	2,2	4,4	5.000	2.150
34-706	MEF-355-3*	3	5,75	5.500	2.550
34-707	MEF-355-1	1,5	8,75	4.350	1.550
34-708	LEF-355-1	0,25	2,05	2.250	425
35-201	LEF-400-3	0,55	1,5	2.500	500
35-202	LEF-400-1	0,55	3,83	2.500	500
35-203	MEF-400-3*	2,2	4,4	3.600	2.150
35-204	MEF-400-1	2,2	13,2	3.600	2.150
35-206	MEF-400-3	4	7,2	6.300	2.150
35-206A	MEF-400-3*	5,5	9,8	7.500	2.810

\* Requires frequency inverter

Pressure drop for LEF/MEF 250 til 315

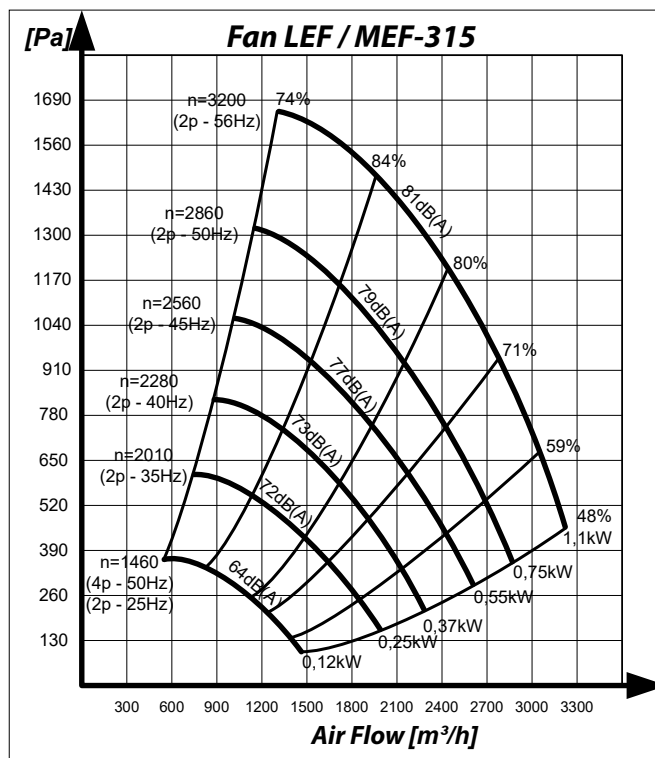
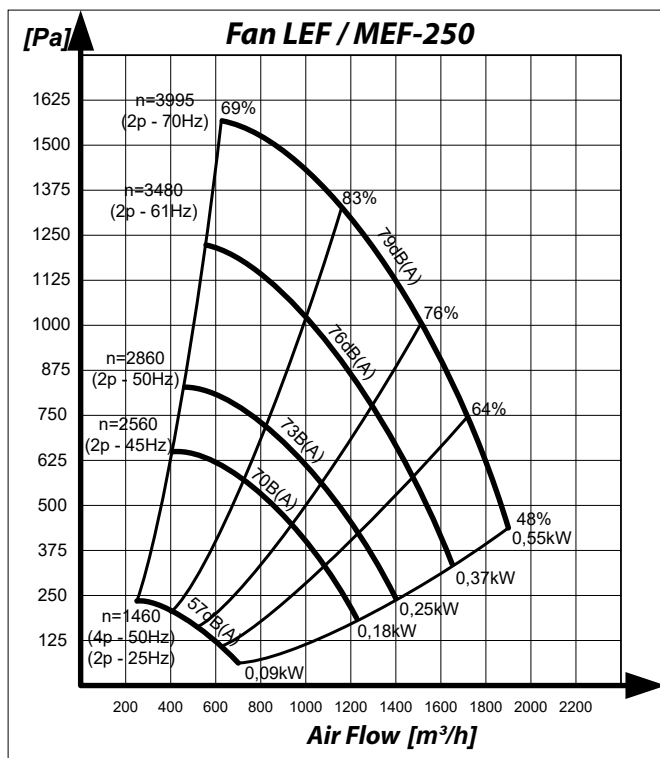

Fans LEF/MEF 450 to 630 – B-impeller, efficiency up to 87%



NB. For motors with power greater than 4kw are supported with console

Art. No.	Description	[kW]	[A]	[m <sup>3</sup> /h]	Max [Pa]
35-701	LEF-450-3	0,75	1,8	4.700	700
35-702	LEF-450-1	0,75	4,9	4.700	700
35-705	MEF-450-3*	4	7,2	6.000	2.600
35-706	MEF-450-3	5,5	9,8	9.000	2.600
35-708	MEF-450-3*	7,5	13,8	10.500	3.100
36-500	MEF-500-3	7,5	13,8	11.400	3.350
36-501	MEF-500-3*	11	19,5	12.500	3.950
36-502	MEF-500-3*	5,5	9,8	10.000	2.900
36-503	MEF-500-3*	4	7,2	6.400	1.800
36-504	LEF-500-3	1,1	2,5	3.600	800
35-801	LEF-560-3	2,2	4,6	8.500	1.050
35-802	MEF-560-3*	7,5	13,8	13.000	2.600
35-803	MEF-560-3*	11	19,5	14.800	3.300
35-804	MEF-560-3	18,5	34,3	17.500	4.500
35-750	MEF-630-3*	22	38,1	24.100	4.500
35-750A	MEF-630-3*	15	26,4	21.500	3.300
35-751	LEF-630-3	4	7,9	14.000	1.600
35-752	LEF-630-3*	7,5	10,8	17.000	2.400
35-753	LEF-630-3*	11	14,2	18.200	2.650
35-755	LEF-630-3*	5,5	21,2	16.200	2.030

\* Requires use of external frequency inverter.

Pressure drop for LEF/MEF 355 til 400

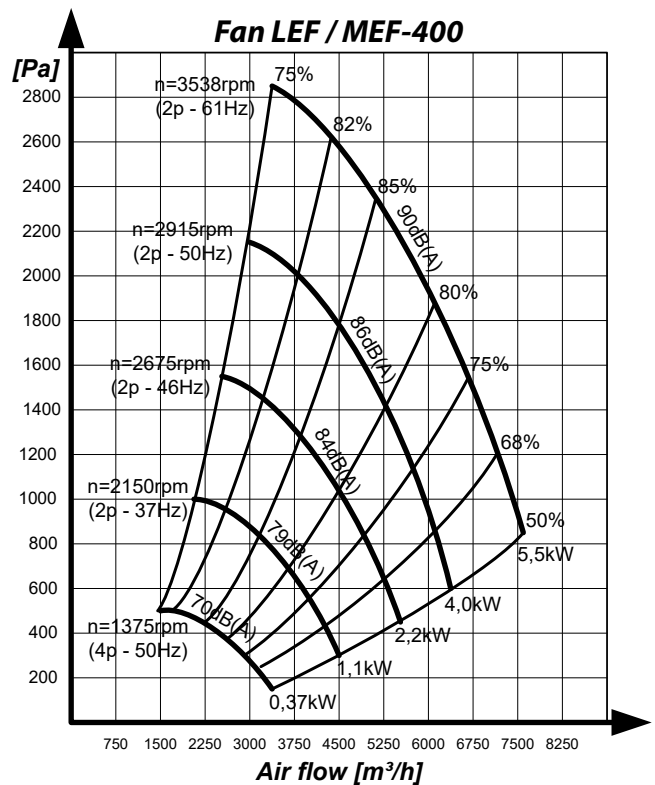
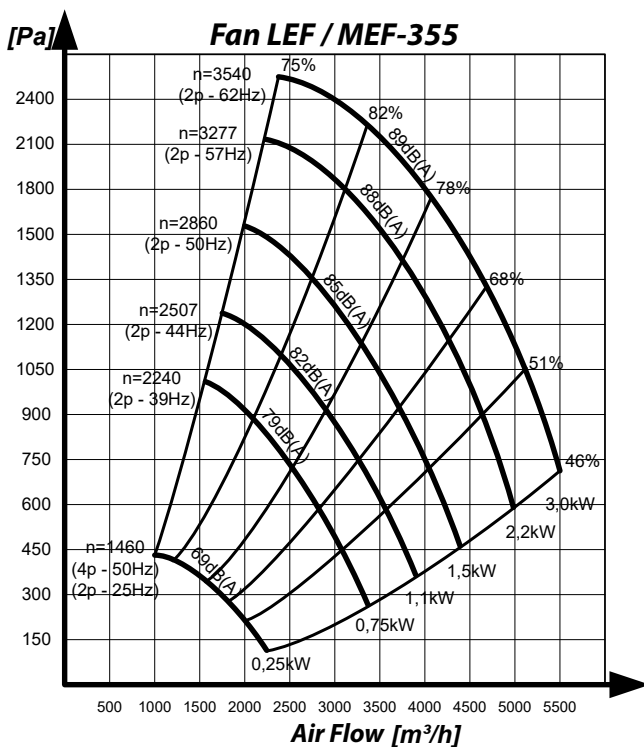



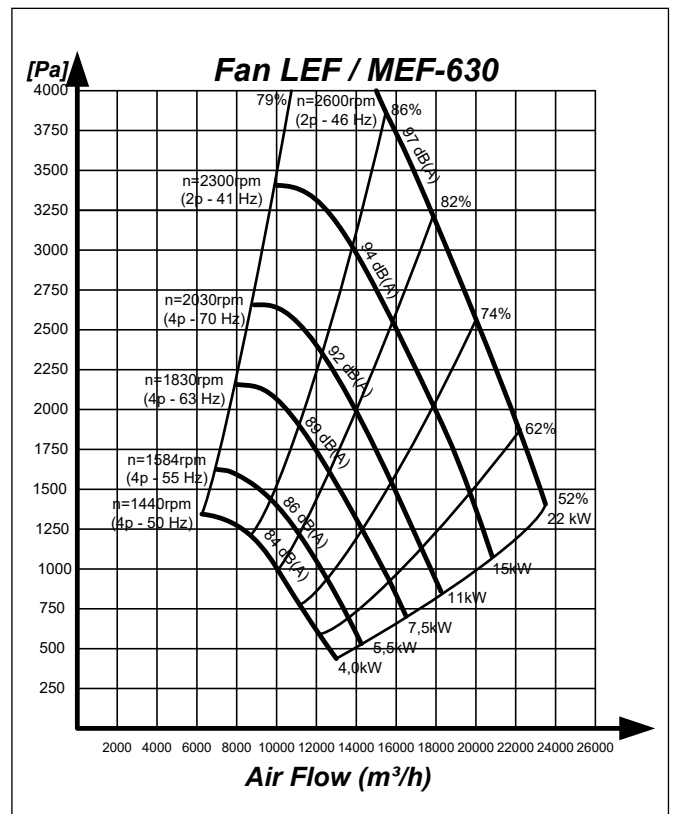
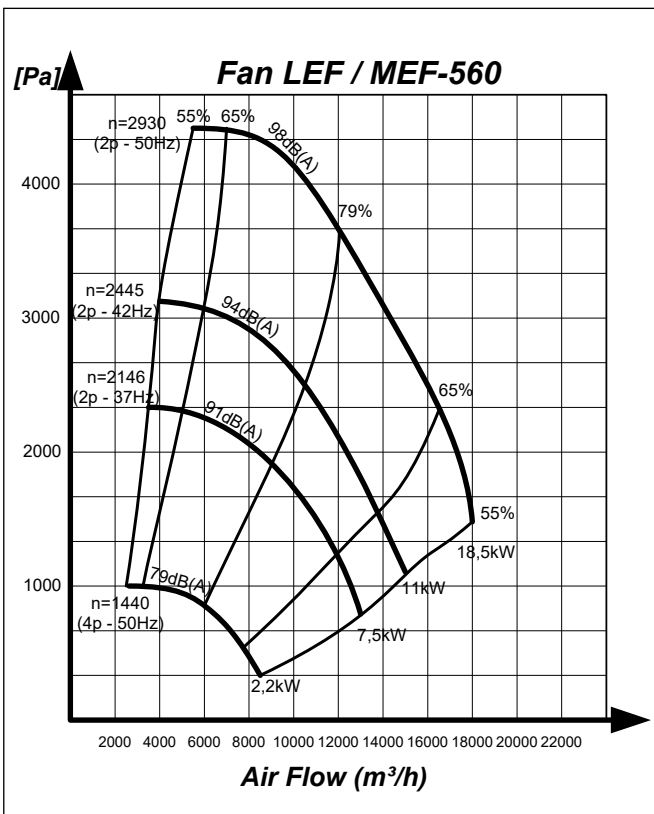
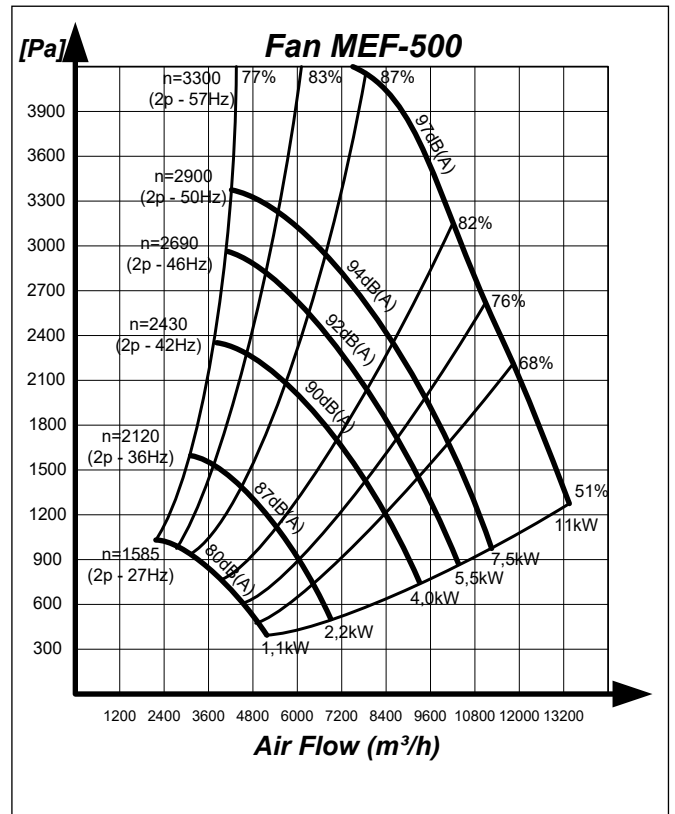
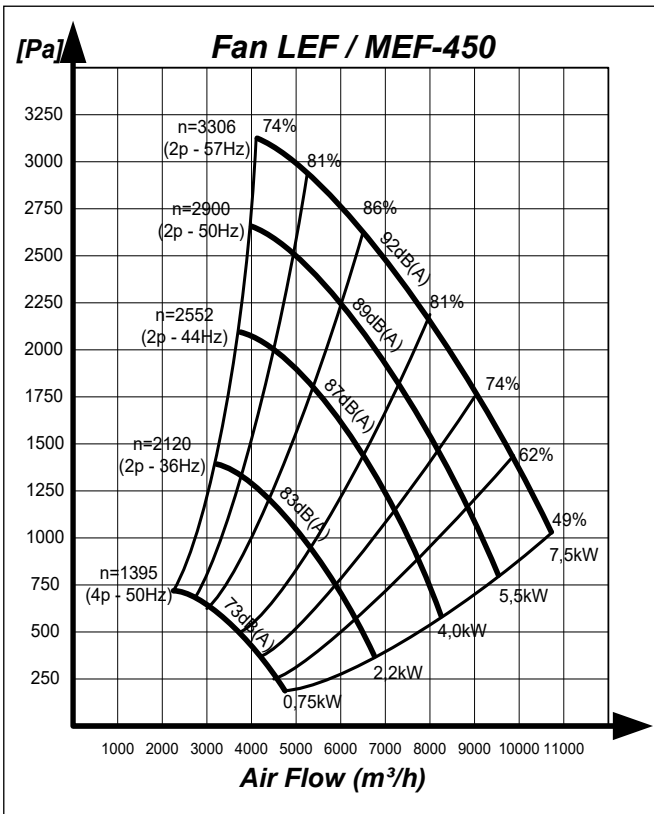

Dimensions, fans LEF/MEF (LEX/MEX)

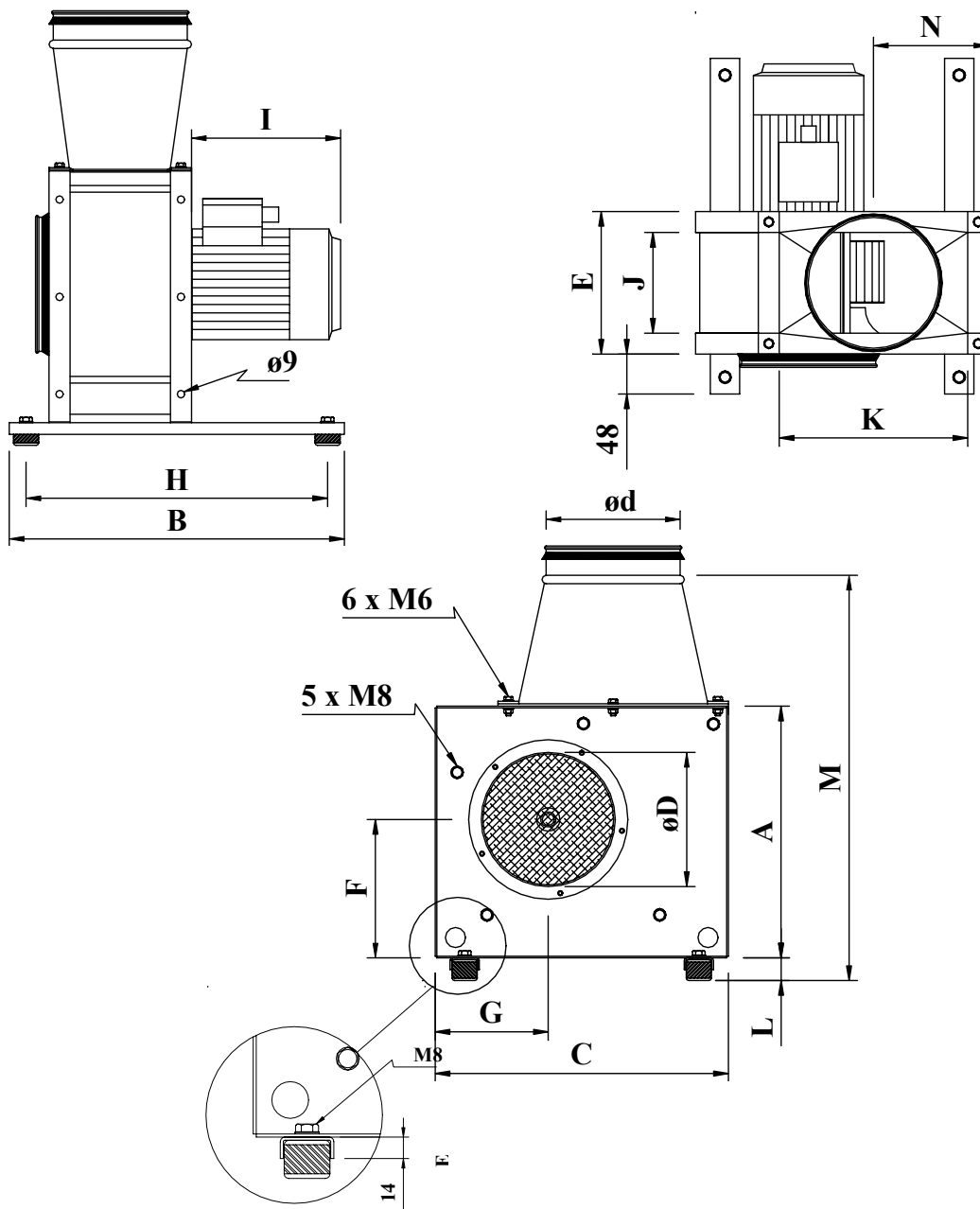

Dimensions, fans LEF/MEF (LEX/MEX)

Type	A	B	C	øD	ød	E	F	G	H	I	J	K	M	N	Weight
250	410	500*	500	250	***	215	230	210	460	**	170	320	637	185	38kg*
315	510	700*	600	315	***	260	290	240	660	**	210	400	720	225	43kg*
355	570	700*	680	400	***	284	329	272	660	**	234	450	797	250	48kg*
400	648	700*	756	400	***	308	367	304	660	**	260	500	965	275	56kg*
450	715	800*	850	500	***	340	408	340	760	**	290	560	1045	305	71kg*
500	758	800*	871	500	***	345	421	362	760	**	295	510	1065	263	81kg*
560	907	800*	1070	630	***	425	523	440	760	**	375	709	1340	380	125kg*
630	989	800*	1175	630	***	446	563	467	760	**	400	800	1340	425	135kg*

\*\*/ - depending on motor. NB: For LEX/MEX versions will the motor typically have larger measures than standard motors, and hence higher weight!

\*\*\* depending on outlet flange

LEF 800 to 1000



Art. No.	Description	[kW]	[A]	Max [m <sup>3</sup> /h]	Max [Pa]
36-600	LEF-800-3	37	67	37.000	4200
36-700	LEF-900-3	37	67	46.000	4100
36-800	LEF-1000-3	45	79,5	55.000	4200

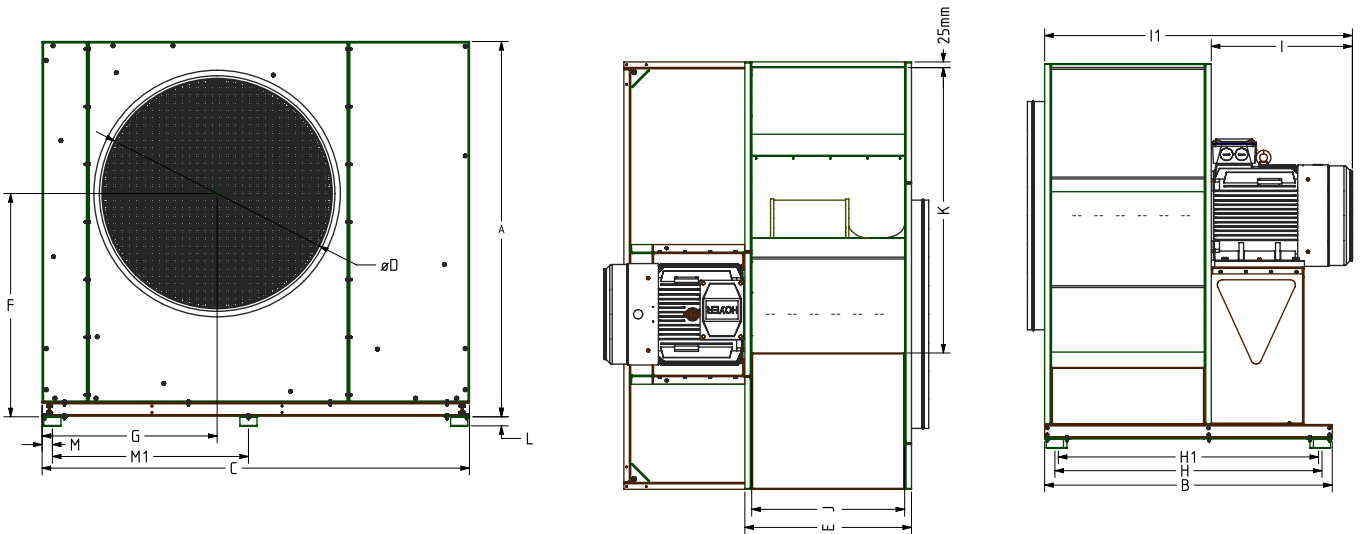

	H1	H	B	I1	I	K	E	J	G	M	M1	C	L	F	A	ØD
LEF-800-3	877	907	997	1200	610	998	590	530	616	45	708	1507	40	801	1339	800
LEF-900-3	995	1020	1110	1253	593	1120	660	600	690	45	800	1690	40	889	1491	1000
LEF-1000-3	1140	1170	1260	1350	620	1250	730	670	766	45	859	1872	40	978	1644	1000



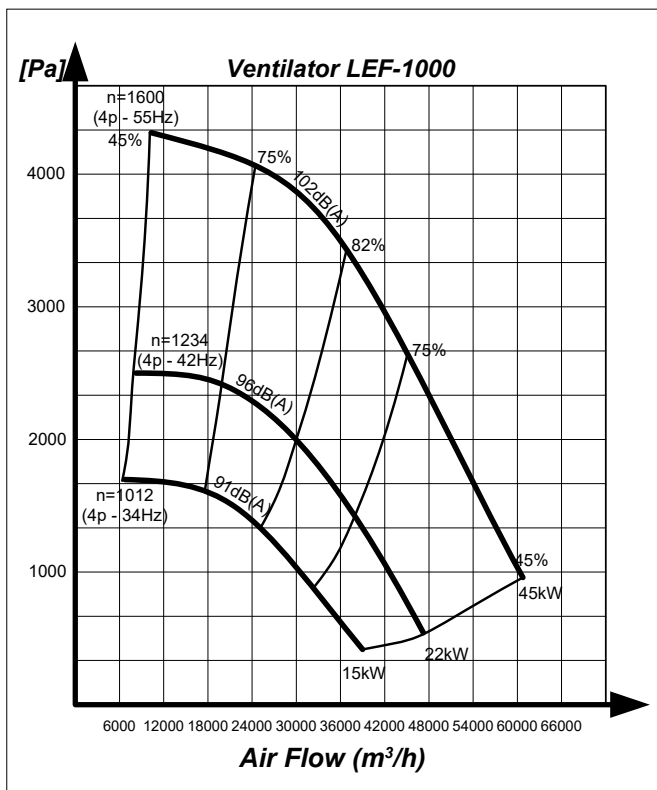
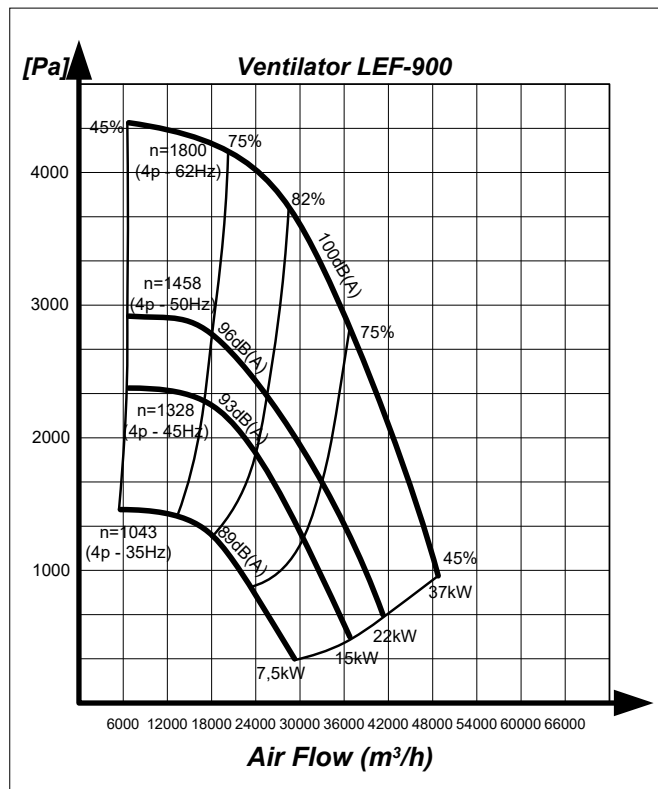
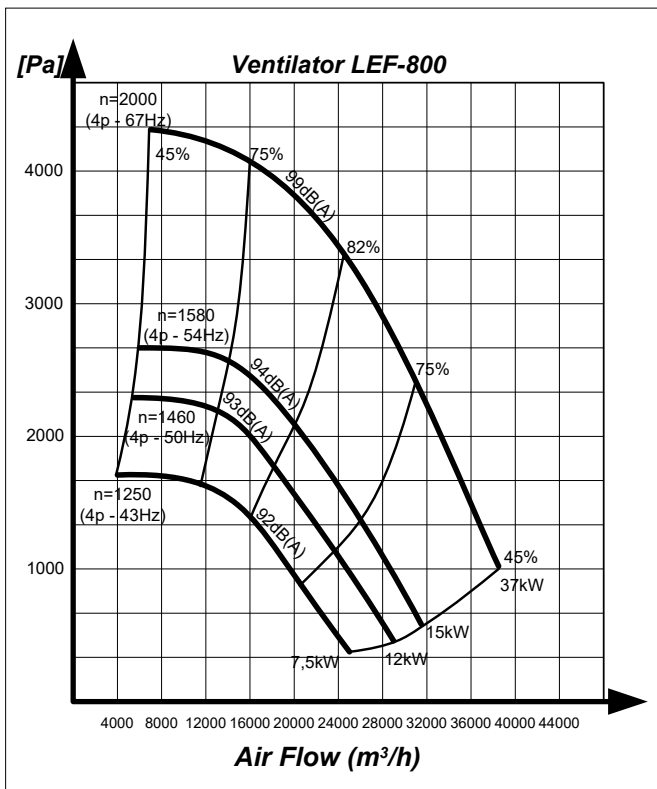

## Accessories for fans



Art. No.	Description
38-072	Sound box2 146
30-072	Sound box2 180
31-072	Sound box2 200
32-072	Sound box2 225
33-072	Sound box2 250
34-072	Sound box2 315
34-572	Sound box2 355
35-072	Sound box2 400
35-572	Sound box2 450
36-572	Sound box2 500
35-872	Sound box2 560
35-772	Sound box2 630

Protects against wind and weather - noise reduction 10-15 dB(A)

## Dimensions, Sound boxes, all measures in mm.

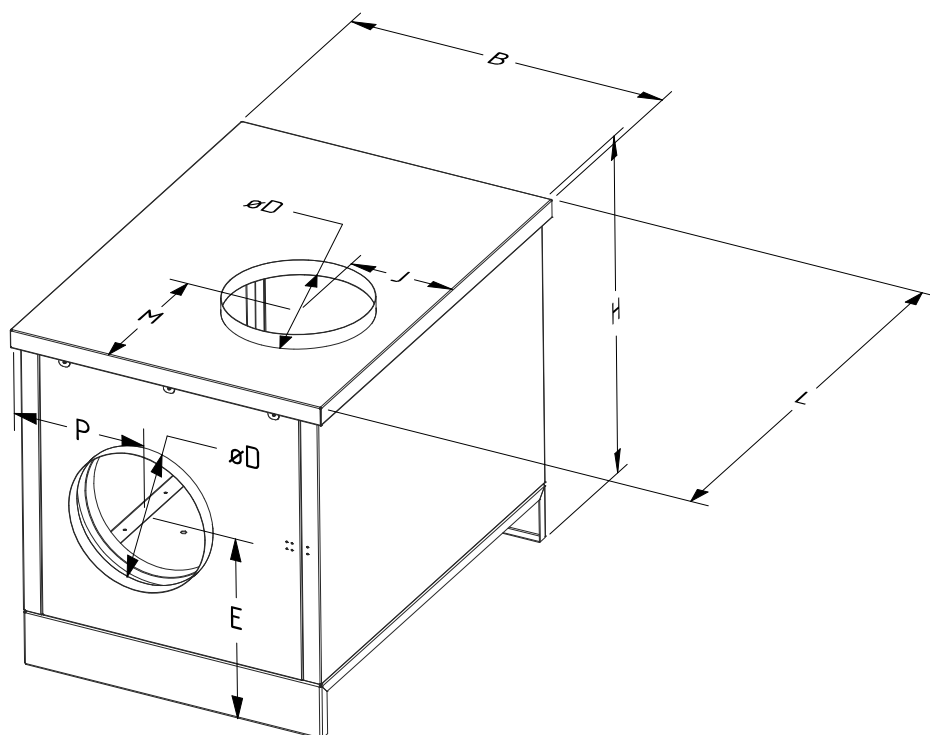

Type	146/180/200	225/250	315	355/400	450/500	560/630
B	518	615	715	873	986	1290
H	592	652	778	915	1046	1277
L	685	784	984	1080	1272	1390
øD	200	250	315	400	500	630
E	330	345	415	485	546	673
P	226	268	298	354	420	525
M	212/262	254	335	308	379	429
J	169/189	205	233	269	318	393
Weight	34 kg.	42 kg.	63 kg.	81 kg.	105 kg.	155 kg.





Art. No.	Description
38-009	Outlet flange 146/ø80
38-015	Outlet flange 146/ø125
38-021	Outlet flange 146/ø160
30-015	Outlet flange 180/ø160
30-019	Outlet flange 180/ø200
31-019	Outlet flange 200/ø160
31-015	Outlet flange 200/ø200
31-015A	Outlet flange 200/ø250
31-015B	Outlet flange 200/ø315
32-019	Outlet flange 225/ø200
32-015	Outlet flange 225/ø250
32-021	Outlet flange 225/ø315
33-015	Outlet flange 250/ø250
33-019	Outlet flange 250/ø200
33-021	Outlet flange 250/ø315
34-015	Outlet flange 315/ø315
34-023	Outlet flange 315/ø400
34-515	Outlet flange 355/ø315
34-519	Outlet flange 355/ø400
35-015	Outlet flange 400/ø400
35-019	Outlet flange 400/ø500
35-021	Outlet flange 400/ø630
35-519	Outlet flange 450/ø400
35-515	Outlet flange 450/ø500
35-521	Outlet flange 450/ø630
36-515	Outlet flange 500/ø500
36-519	Outlet flange 500/ø630
35-815	Outlet flange 560/ø500
35-819	Outlet flange 560/ø630
35-821	Outlet flange 560/ø800
35-774	Outlet flange 630/ø500
35-775	Outlet flange 630/ø630
35-776	Outlet flange 630/ø800

Other sizes on request



**Art. No. Description**

38-060	Rain cover 146
30-060	Rain cover 180
31-060	Rain cover 200
32-060	Rain cover 225
33-060	Rain cover 250
34-060	Rain cover 315
34-560	Rain cover 355
35-060	Rain cover 400
35-560	Rain cover 450
36-560	Rain cover 500
35-660	Rain cover 560
35-780	Rain cover 630



07-150	Wall bracket 146 to 200 (2-piece set)
07-151	Wall bracket 225 to 250 (2-piece set)
07-152	Wall bracket 315 to 355 (2-piece set)
07-153	Wall bracket 400 to 450 (2-piece set)
07-154	Wall bracket 500 (3-piece set)
07-155	Wall bracket 630 (4-piece set)

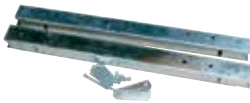

07-068	Roof console GB 15-45°
07-069	Roof console 0-5°



92-200	Manual circuit breaker - adjustment range: 0,4-0,63 A
92-201	Manual circuit breaker - adjustment range: 0,63-1,00 A
92-202	Manual circuit breaker - adjustment range: 1,00-1,60 A
92-203	Manual circuit breaker - adjustment range: 1,60-2,50 A
92-204	Manual circuit breaker - adjustment range: 2,50-4,00 A
92-205	Manual circuit breaker - adjustment range: 4,00-6,30 A
92-206	Manual circuit breaker - adjustment range: 6,00-10,0 A
92-207	Manual circuit breaker - adjustment range: 9,00-14,0 A
92-208	Manual circuit breaker - adjustment range: 13,0-18,0 A
92-209	Manual circuit breaker - adjustment range: 17,0-23,0 A

92-210	Breaker switch for canceling process monitor/pressure switch. Mounted with circuit breaker.
92-210A	230V Changeover contact NO/NC



07-160	Flexible connection ø160 mm
07-161	Flexible connection ø200 mm
07-162	Flexible connection ø250 mm
07-163	Flexible connection ø315 mm
07-164	Flexible connection ø400 mm
07-165	Flexible connection ø500 mm
07-166	Flexible connection ø630 mm

## Fan for direct mounting on hose reel type GTE and GTS and on WING and COMPACT arms



### Art. No. Description

31-209	Fan MSQ-200-3 0,75kW, 3x400V, 1.400 m <sup>3</sup> /h - 1,9A
31-208	Fan MSQ-200-1 0,75 kW, 1x230V, 1.400 m <sup>3</sup> /h - 4,9A
31-019	Outlet flange 200/ø160 for MSQ-200
04-460A	Mounting bracket for hose reel GTE and GTS (factory mounted). For mounting fan MSQ directly on the side of a hose reel.
31-201	Adapter for mounting on wall console for ø160 arms
31-207	Adapter for mounting on wall console for ø200 arms

## Fans MHF 400 to 500 - with closed B-impeller



Centrifugal fan with closed wheel with backward curved blades and direct driven flange motor. The MHF-fan is used for industrial process extraction. The MHF-fan delivers a high pressure and is ideal for PID/constant pressure regulation.

Art. No.	Description	[kW]	[A]	[m <sup>3</sup> /h]	Max [Pa]
35-450	MHF-400-3 3x400V, 50Hz	1,1	2,4	1300	2500
36-550	MHF-500-3 3x400V, 50Hz	4	7,2	2600	4000
36-550A	MHF-500-3 3x400V, 65Hz	5,5	9,8	3.200	5.500

## Pressure drop and dimensions, fan MHF 400 to 500

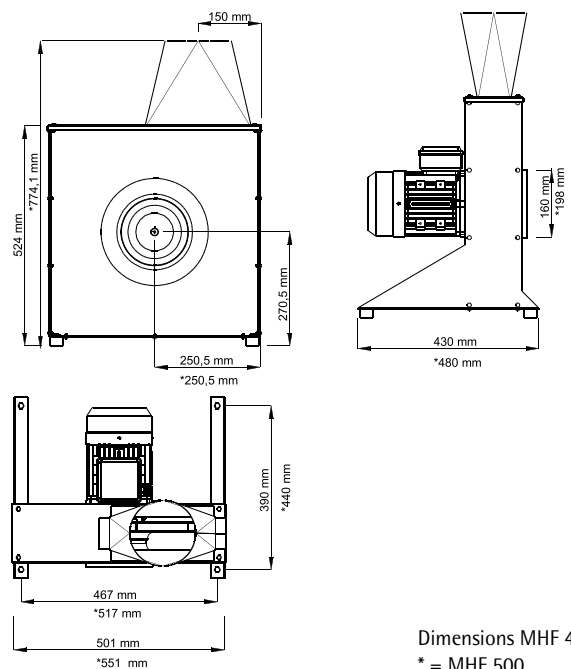
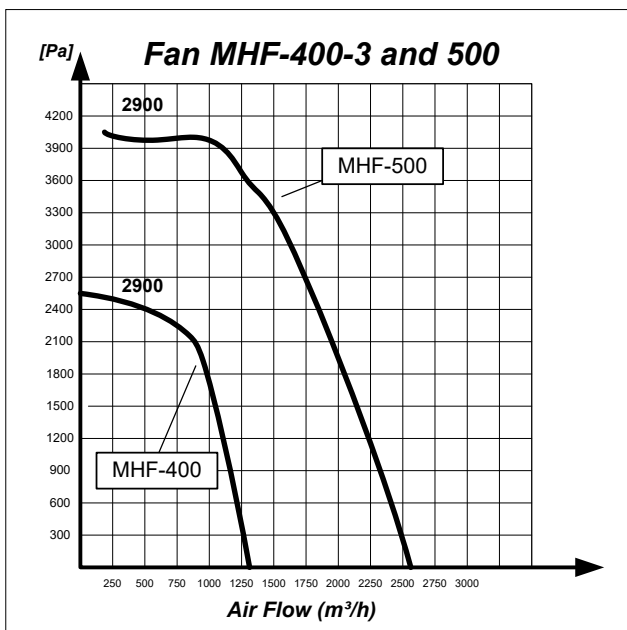

GEOVENT plastic fans are suitable for extraction in corrosive environments - e.g. laboratories, battery rooms, chemical cupboards and more.  
Both fan house and wheel is constructed in heavy duty polypropylene (PP). Air flows up to 6.700m<sup>3</sup>/m and available pressure up to 1.700 Pa.



Art. No.	Description	[kW]	[A]	[rpm]	Max [m <sup>3</sup> /h]	Max [Pa]
38-100	LPV-124-3	0,09	0,37	1.500	100	60
38-101	LPV-124-1	0,09	0,85	1.400	100	60
38-102	MPV-122-3	0,12	0,4	2.800	175	280
38-103	MPV-125-1	0,12	0,95	2.800	175	280
38-103X	MPX-125-1	0,12	0,38	2.800	175	280
38-104X	LPX-125-1	0,12	0,16	1.400	100	60
38-106	MPV 202	0,18	0,49	2.750	1.080	470
38-108	LPV 254	0,12	0,42	1.370	1.080	160
38-110	MPV 252	0,37	0,87	2.820	2.100	750
38-112	LPV 284	0,18	0,58	1.370	1.500	240
38-114	MPV 282	0,75	1,66	2.820	3.360	1.100
38-116	LPV 314	0,25	0,8	1.400	2.100	290
38-118	MPV 312	1,5	3,15	2.850	4.260	1.320
38-120	LPV 354	0,37	1,13	1.400	3.000	380
38-122	MPV 352	2,2	4,4	2.870	6.720	1.700
38-124	RPV 406	0,25	1	920	2.700	240
38-126	LPV 404	0,55	1,75	1.420	4.260	520
38-130	RPV 456	0,37	1,25	920	3.780	290
38-132	LPV 454	1,1	2,6	1.420	6.000	650

Plastic fans are available in 1-phase versions and ATEX versions (zone 2/22). Enquire for prices.

Dimensions for plastic fans

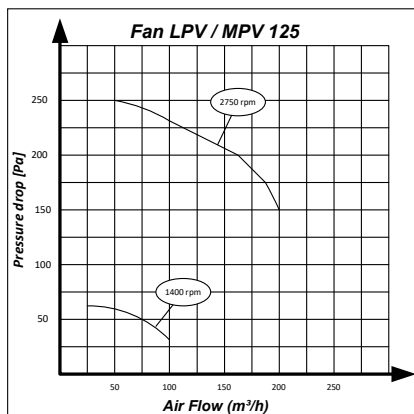
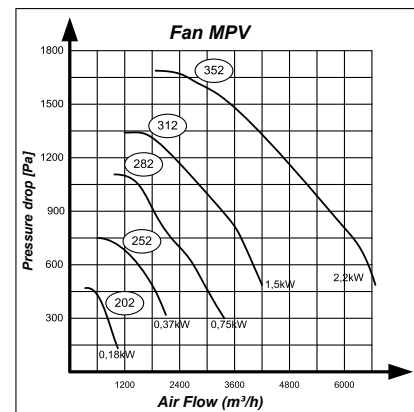
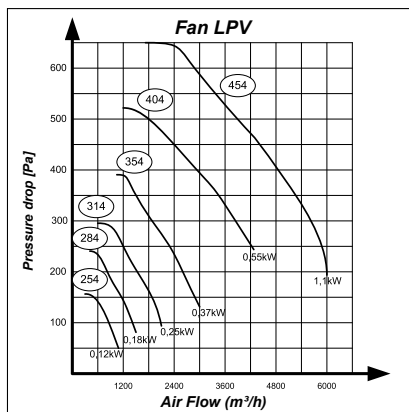
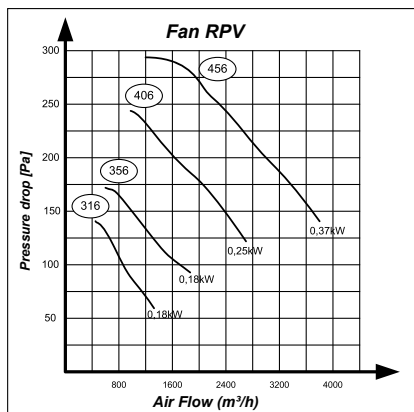

## Dimensions, plastic fans

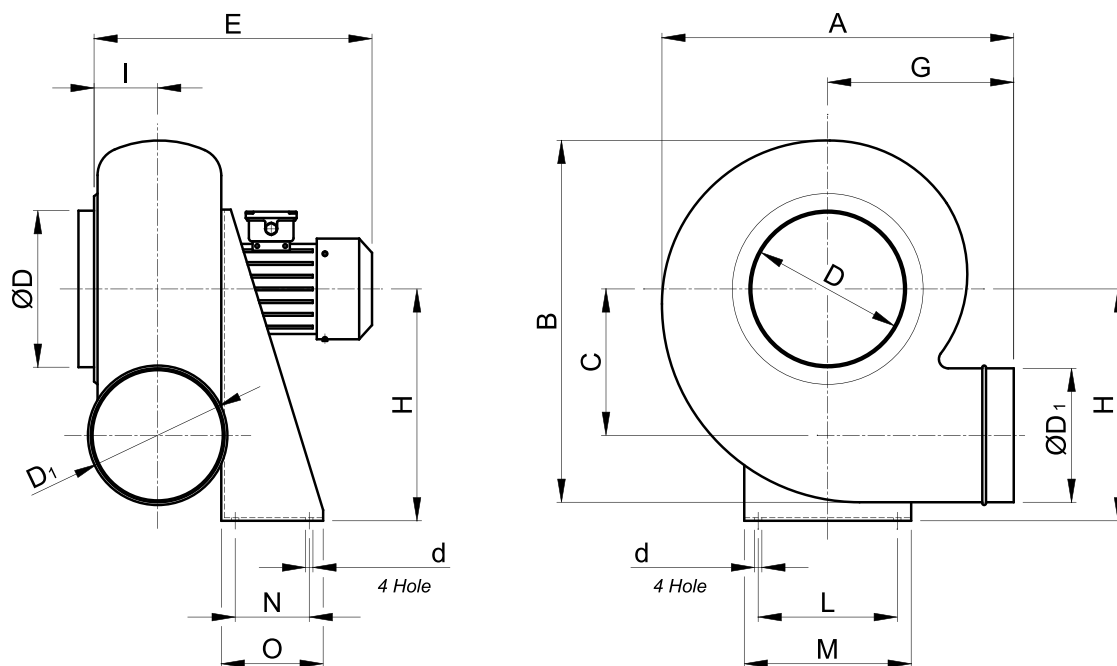

## Dimensions, plastic fans

	rpm	kW	A	B	C	E	G	H	I	D	ØD1	L	M	N	O	d	kg	dB(A)
MPV 125	2.750	0,12	252	196	0	-	152	172	52,5	75	75	117	155	40	82	10	5,5	-
MPV 202	2.750	0,18	398	370	140	340	218	250	75	160	160	195	245	100	150	10	10	62
MPV 252	2.820	0,37	478	465	183	390	250	310	90	200	200	252	302	100	150	10	12	71
MPV 282	2.820	0,75	555	520	208	422	300	350	95	225	225	277	327	120	170	10	22	75
MPV 312	2.850	1,5	600	580	240	445	320	410	100	250	250	315	365	150	200	10	31	79
MPV 352	2.870	2,2	552	640	260	490	340	445	110	280	280	345	395	150	200	10	38	80
LPV 254	1.370	0,12	478	465	183	370	250	310	90	200	200	252	302	100	150	10	10	54
LPV 284	1.370	0,16	555	520	208	380	300	350	95	225	225	277	327	120	170	10	17	55
LPV 314	1.400	0,25	600	580	240	410	320	410	100	250	250	315	365	150	200	10	23	59
LPV 354	1.400	0,37	652	640	260	430	340	445	110	280	280	345	395	150	200	10	28	61
LPV 404	1.420	0,55	726	723	290	472	374	495	120	315	315	465	515	170	220	10	38	69
LPV 454	1.420	1,1	792	810	324	510	400	550	133	355	355	510	560	170	220	10	48	70
RPV 316	930	0,18	600	580	240	410	320	410	100	250	250	315	365	150	200	10	20	50
RPV 356	930	0,18	652	640	260	430	340	445	110	280	280	345	395	150	200	10	22	53
RPV 406	920	0,25	726	723	290	450	374	495	120	315	315	465	515	170	220	10	34	56
RPV 456	920	0,37	792	810	324	497	400	550	133	365	355	510	560	170	220	10	37	59





GEOVENT supplies portable and mobile ventilation and extraction solutions for use on board ships, off shore, in farming, for service engineers and industry. Common to all tasks is that it is difficult and some times impossible to establish a fixed point of extraction as the tasks are where the operator is working, e.g. welding jobs on building material, paint jobs, or repair work on board ships or oil rigs.

The outlet hose is placed outside so the operator is not exposed to hazardous fumes, smoke or particles.

Note: Recirculation is not always in compliance with local regulations, therefore we recommend using a hose on the fan outlet and place it outside.

Art. No.	Description	[kW]	[A]	Max [m³/h]	Max [Pa]
	PM-180-1	0,55kW	3,93	1400	950
30-006A	Including 10 m ø125mm GeoFlex WELD hose, hood with magnet, thermal protection with breaker and 10m cable 1x230V with plug. Airflow up to 700m³/h, less if the hose is bent.				
30-006H	Including 10 m ø160mm GeoFlex WELD hose, hood with magnet, thermal protection with breaker and 10m cable 1x230V with plug. Airflow up to 1.100m³/h, less if the hose is bent.				
30-007	Additional charge for transport cart				
09-310A	Extra 10m hose with MF/NP quick coupling, ø125 mm				
09-313H	Extra 10m hose with MF/NP quick coupling, ø160 mm				



Mobile extractor designed for various extraction tasks where filtering of the extracted air is needed, i.e. welding and soldering jobs. The arm is selected according to the type of job for which it is going to be used, and is available with a quick coupling system which makes it more flexible and suitable for various purposes.

Art. No.	Description
15-200	W3 Filter unit, 1,1kW 1x230V



Mobile extractor with fixed extraction arm. Very suitable for tasks like painting, gluing and other jobs involving organic solvents. Highly portable and easy to lift from a van.

Complete with 1 m ø125 mm Flexi arm, with transparent polycarbonate hood, 1,1kW motor for 1x230V with 10 m cable, sparkproof inlet and 10 m outlet hose ø160 mm. Max airflow: 400-700m³/h.

Art. No.	Description
01-590	Mobile extractor MVF-125-1, exclusive filter



Mobile extractor with fixed ASA3-arm. Used in i.e. repair shops where a fixed arm is inconvenient. Powdercoated black steel with wheels and low center of gravity. Height (without arm): 1700mm. Complete set with MSFG-200-3 fan, 3x400V with 10m cable, ASA3-arm ø160 mm and 5m. outlet hose. Also available without fan.

Art. No.	Description
10-270-2W	Mobile extractor with 2 m. ASA arm
10-270-3W	Mobile extractor with 3 m. ASA arm

## Portable, mobile fans



GeoGo is a mobile unit with built-in filters. It is designed to be used in changing workplaces, e.g. for welding and grinding. GeoGo is provided with a 1,1 kW 230V fan and a 3 meter ASA4 arm  $\varnothing$ 160mm with a hood, an aluminum metal pre-filter, and a V-bank F9 filter. GeoGo comes with a 10 m cable with a plug that fits a standard wall outlet. It has strong rubber wheels, where the front wheels are turntable and with brakes, which ensures that GeoGo is easily moved and stable at work. Max. up to 1450 m<sup>3</sup>/h. Weight without arm: 120 kg.

Art. No.	Description	[kW]	[A]
15-210	GeoGo W3	1,1kW	6,5A
15-211	GeoGo V-Bank - F9	1,1kW	6,5A
15-212	GeoGo Hepa H13	1,1kW	6,5A
15-213	GeoGo 1x110V	1,1kW	6,5A

01-008-G	WING arm 2,0m $\varnothing$ 160mm
01-009-G	WING arm 3,0m $\varnothing$ 160mm

01-650-G	ESA arm 2,0m $\varnothing$ 160mm
01-651-G	ESA arm 3,0m $\varnothing$ 160mm

ASA4-2-160-G	ASA-4 arm 2,0m $\varnothing$ 160mm
ASA4-3-160-G	ASA-4 arm 3,0m $\varnothing$ 160mm

15-211-A	V-Bank F9 595x595x292
15-211-B	V-Bank Filter HEPA 595x595x292
15-211-C	Metal filter Alu 595x595x20

## Wood dust extraction

Art. No.	Description	[kW]	[A]	Max [m <sup>3</sup> /h]	Max [Pa]
03-750	GeoJet WE-55 unit	5,5kW	11,5A	1800m <sup>3</sup> /h	8000Pa



WE55 is a central vacuum unit, perfectly suited for schools. WE55 can be used as vacuum cleaner as well as transport of particles.

With a capacity of 5.5 kW (1.800 m<sup>3</sup>/h – 8.000 Pa) it ensures a clean and healthy working environment without any air particles in the room.

The control unit has the possibility for automatically start/stop and filter shake at shut down.

The bin sensor stops the unit as soon as the bag is full.

Please do not hesitate to contact us.



## Duct-, Box fans

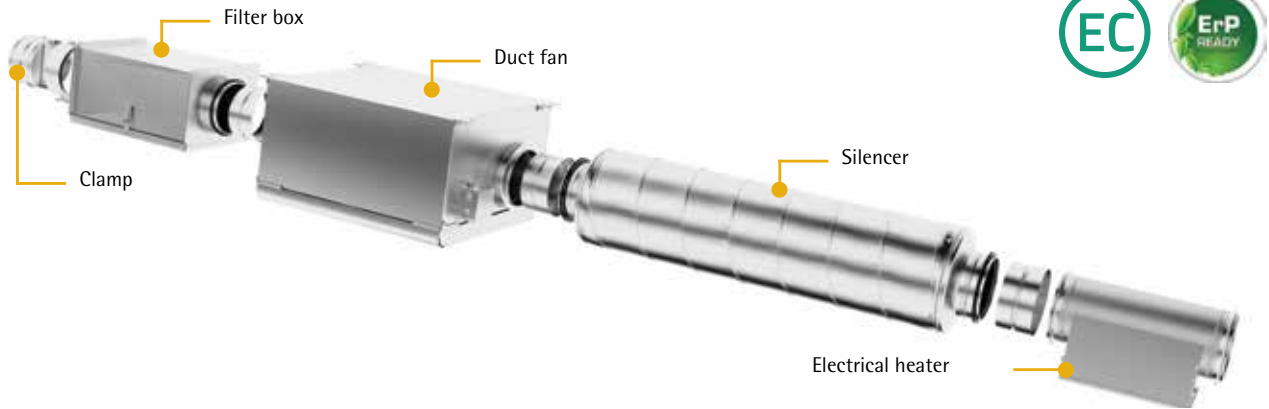

Duct fans are mostly used in low-to medium-pressure ducted systems with additional components such as heaters, filter boxes, dampers, etc.

## VKA EKO - EC-Fans



Duct fan with backward-curved impeller and 1-phase EC-Fan. Surrounding temperature range: - 25°C to + 60°C. For indoor mounting.

Art. No.	Description	[kW]	[A]	Max [m <sup>3</sup> /h]	Max [Pa]
39-100	Duct fan VKA-125 EC	0,085	0,87	446	698
39-101	Duct fan VKA-160 EC	0,083	0,88	504	617
39-102	Duct fan VKA-200 EC	0,170	1,59	1.110	862
39-103	Duct fan VKA-250 EC	0,170	1,32	1.148	899
39-104	Duct fan VKA-315 EC	0,166	1,56	1.327	670

## Pressure drop

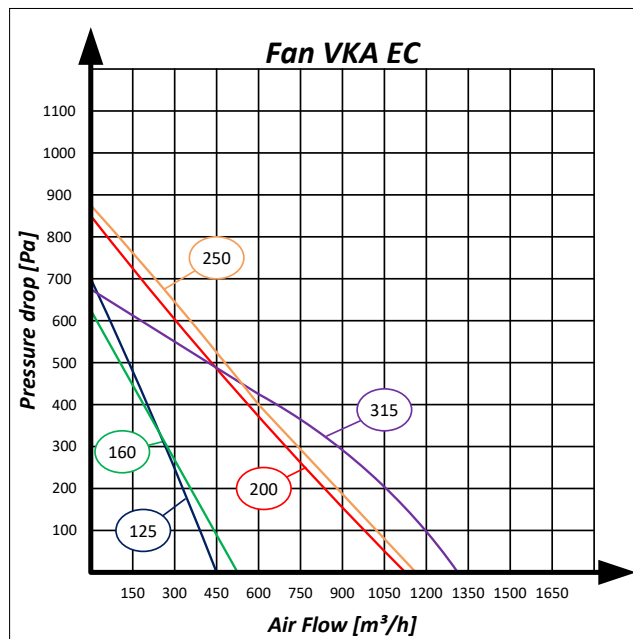

## AKU EKO - EC-Fans



Duct fan with backward-curved impeller and 1-phase EC-Fan. Surrounding temperature range: - 25°C to + 60°C. Sound box with 50 mm isolation. For indoor mounting.

Art. No.	Description	[kW]	[A]	Max [m³/h]	Max [Pa]
39-110	Duct fan AKU-125 EC	0,05	0,40	296	363
39-111	Duct fan AKU-160 EC	0,11	0,99	632	914
39-112	Duct fan AKU-200 EC	0,20	1,45	1.101	1.150
39-113	Duct fan AKU-250 EC	0,21	1,69	1.184	1.000
39-114	Duct fan AKU-315 EC	0,40	3,00	1.642	966
39-115	Duct fan AKU-500x250 EC	0,54	2,48	2.805	798
39-116	Duct fan AKU-700x400 EC	0,95	4,32	4.436	850
39-117	Duct fan AKU-700x400 EC	1,33	5,80	5.313	1.035

## KUB EKO - EC-Fans



Duct fan with backward-curved impeller with 1- and 3-phase EC-Fan. Surrounding temperature range: - 20°C to + 60°C. Sound box with 20 mm isolation. For indoor or outdoor mounting.

Art. No.	Description	Volt	[kW]	[A]	Max [m³/h]	Max [Pa]
39-120	Duct fan KUB 50-355 EC	230V	0,42	1,95	3.007	573
39-121	Duct fan KUB 67-400 EC	230V	0,79	3,55	5.227	686
39-122	Duct fan KUB 67-500 EC	400V	1,28	2,04	8.071	699
39-123	Duct fan KUB 80-500 EC	400V	1,24	1,96	8.370	686
39-124	Duct fan KUB 80-560 EC	400V	1,59	2,49	10.744	688
39-125	Duct fan KUB 80-630 EC	400V	3,00	4,55	15.000	881
39-126	Duct fan KUB 100-630 EC	400V	2,94	4,51	15.900	850

## Outlet flange



### Art. No. Description

39-120A	Outlet flange KUB 50-355 EC
39-121A	Outlet flange KUB 67-400 EC
39-122A	Outlet flange KUB 67-500 EC
39-123A	Outlet flange KUB 80-500 EC
39-124A	Outlet flange KUB 80-560 EC
39-125A	Outlet flange KUB 80-630 EC
39-126A	Outlet flange KUB 100-630 EC

## Pressure drop

Dark green: Box fan KUB 80-500 EC  
 Green: Box fan KUB 67-500 EC  
 Yellow: Box fan KUB 100-630 EC  
 Red: Box fan KUB 80-630 EC

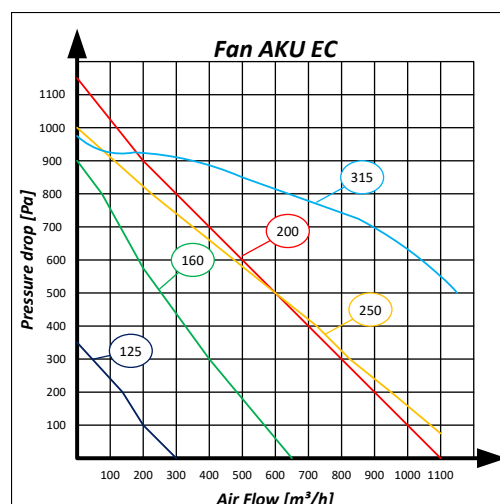
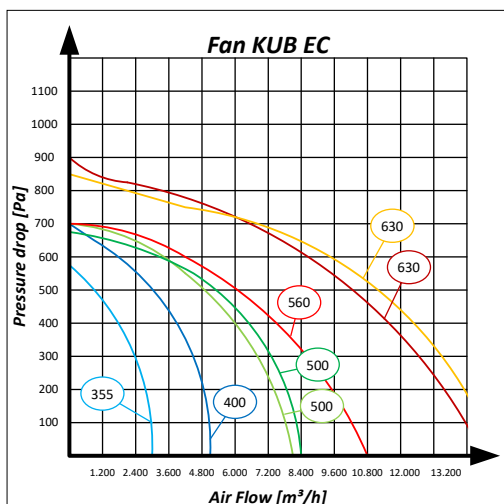

## Kitchen fan

Kitchen fans are used to extract air in ventilation systems where the air is up to 120° C and has higher levels of humidity and impurities like grease. These fans' motors have higher protection class of IP54. Units are equipped with easily removable grease trays and are service friendly.

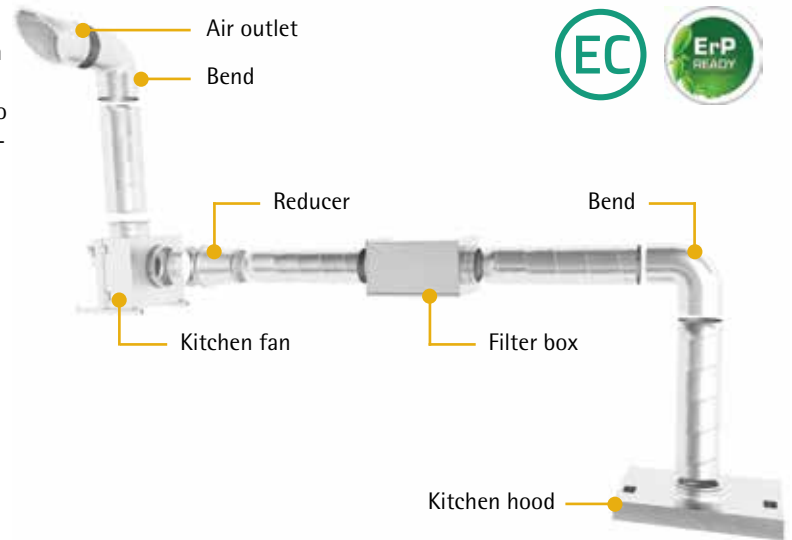

### KF T120 EC - EC-Fans



Kitchen fan with backward-curved impeller with 1- and 3-phase EC-Fan. Surrounding temperature range: - 25°C to + 60°C. Sound box with 50 mm isolation. For indoor or outdoor mounting.

Art. No.	Description	Volt	[kW]	[A]	Max [m <sup>3</sup> /h]	Max [Pa]
39-160	Kitchen fan KF-B-315 EC	230V	0,15	0,70	1.977	370
39-161	Kitchen fan KF-B-355 EC	230V	0,15	0,70	2.776	476
39-162	Kitchen fan KF-B-400 EC	230V	0,44	1,90	3.771	634
39-163	Kitchen fan KF-F-160 EC	230V	0,13	1,20	1.052	181
39-164	Kitchen fan KF-F-180 EC	230V	0,25	1,20	1.680	248
39-165	Kitchen fan KF-F-200 EC	230V	0,45	2,00	2.435	332
39-166	Kitchen fan KF-F-250 EC	230V	0,74	3,20	3.176	515
39-167	Kitchen fan KF-F-280 EC	400V	2,60	4,00	6.663	703

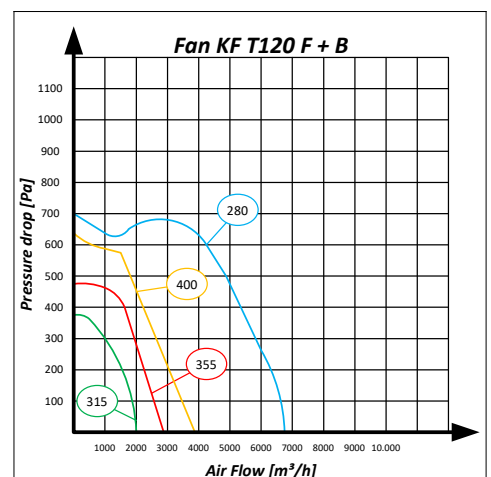
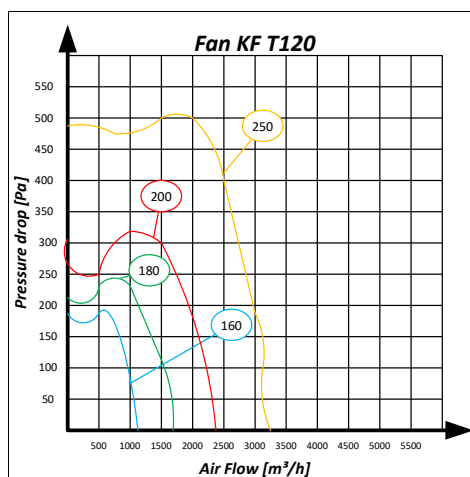



## KUB T120 - Fans

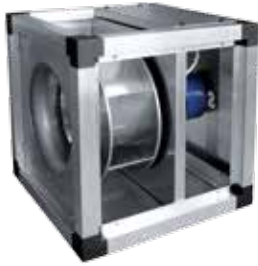

Kitchen fan with backward-curved impeller and 3-phase Fan. Surrounding temperature range: - 40°C to + 40°C. Sound box with 20 mm isolation. For indoor or outdoor mounting.

Art. No.	Description	[kW]	[A]	Max [m³/h]	Max [Pa]
39-170	Kitchen fan KUB-355-3	0,35	1,06	2.619	465
39-171	Kitchen fan KUB-400-3	0,54	1,38	3.976	521
39-172	Kitchen fan KUB-450-3	0,92	2,13	5.645	740
39-173	Kitchen fan KUB-500-3	1,44	3,08	7.404	868
39-174	Kitchen fan KUB-560-3	2,50	5,04	10.942	1.050
39-175	Kitchen fan KUB-630-3	4,88	8,90	15.100	1.350

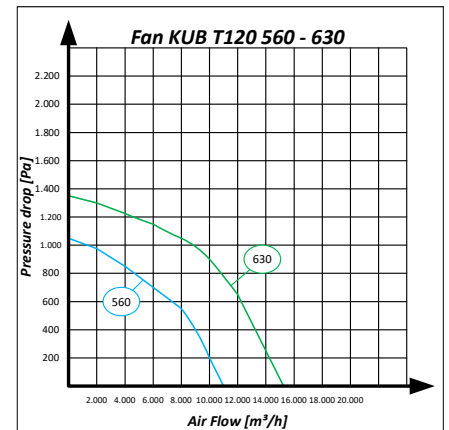
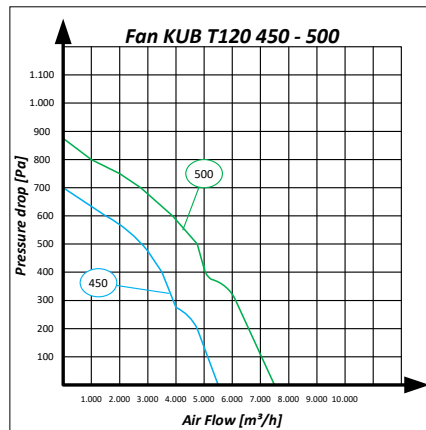
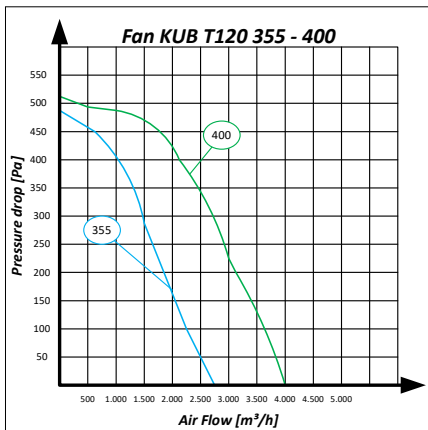

## KF T120 - Fans



Kitchen fan with backward-curved impeller and 3-phase Fan. Surrounding temperature range: - 40°C to + 40°C. Sound box with 50 mm isolation. For indoor or outdoor mounting.

Art. No.	Description	[kW]	[A]	Max [m³/h]	Max [Pa]
39-180	Kitchen fan KF-160-3	0,18	0,57	849	173
39-181	Kitchen fan KF-180-3	0,29	1,00	1.303	222
39-182	Kitchen fan KF-200-3	0,54	1,44	1.826	323
39-183	Kitchen fan KF-225-3	0,92	1,72	2.860	386
39-184	Kitchen fan KF-250-3	1,60	3,37	4.500	562
39-185	Kitchen fan KF-280-3	2,66	4,70	5.391	656
39-186	Kitchen fan KF-315-3	0,18	0,68	1.676	338
39-187	Kitchen fan KF-355-3	0,29	0,98	2.561	455

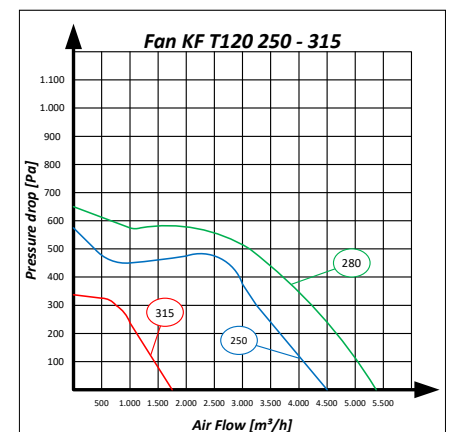
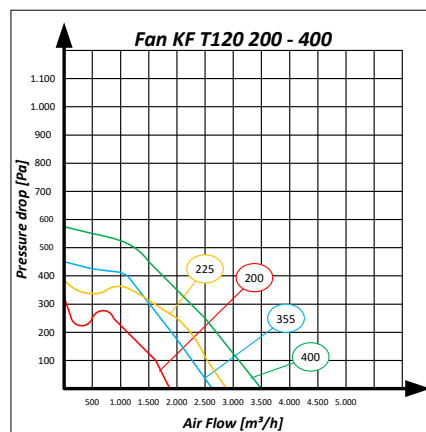
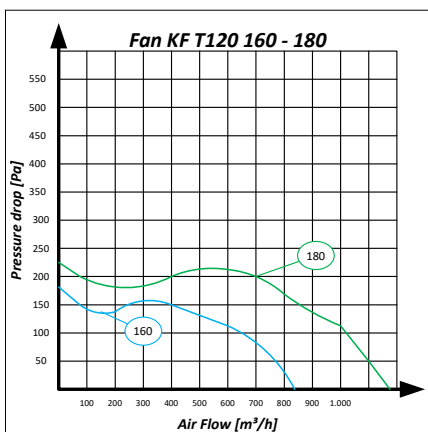

# AUTOMATICS



GEOVENT offers a wide range of options for ventilation and extraction controls.

- Automatic start / stop of ventilation unit  
- Saves energy and increases comfort for the employees.
- Make the user aware in case of failure of the ventilation unit.
- Control of airflow by pressure. Always adapt to the correct level.
- This reduces energy consumption significantly.

**PowerSmart II** ensures that there is always extraction when needed. It turns off automatically when the process stops. This means an insignificant economic gain as heated air is not extracted unnecessarily out of the building, unnecessary noise is reduced and the comfort of the operator is increased. Win, Win!



# AUTOMATICS

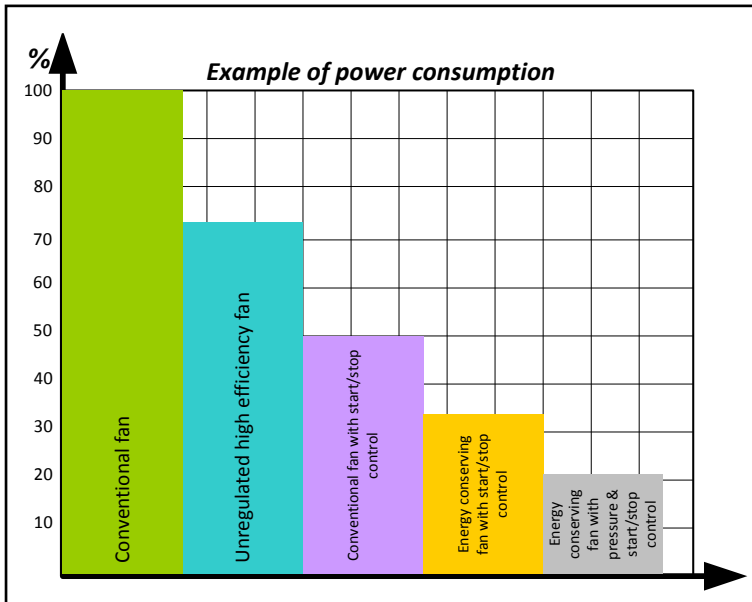

## Energy saving automatics

Save money on electricity and heating

Studies show that most point extraction installations are only used efficiently 5 - 20 % of the time during a working day. As a result there are substantial savings by optimizing use of the installation. Geovent offers several solutions helping you to save on electricity and heating. Normally the Return-of-investment is within 1 - 3 years.



### Fast action motor damper - GFD

Normal motor dampers does not turn fast enough for use with point extraction as the pollution starts instantly.

Geovents GFD fast turning damper opens in just one second and secures instant and efficient extraction.

24 V AC/DC On/off or modulating via 0-10V transformer or Powersmart/Powerbox.

Control type	Exhaust gas	Welding smoke	Grind dust	Oil mist
1 Point of extraction	Start/stop	Start/stop	Start/stop	Start/stop
2-4 Point of extraction	Start/stop	Pressure control	Start/stop	Start/stop
5-8 Point of extraction	Start/stop	Pressure control	Pressure control	Pressure control
9-12 Point of extraction	Start/stop	Pressure control	Pressure control	Pressure control
> 12 Point of extraction	Pressure control	Pressure control	Pressure control	Pressure control

# FREQUENCY INVERTERS



GEOVENT has chosen to sell ABB quality frequency inverters. Because of its very user-friendly setup it is ideal for use with our fans and MultiBox III.

We offer ABB frequency inverters at competitive prices. Further we can advise you on how to connect them to our other products.

We have 2 different series in our program, so there is always a model that suits the task.

All frequency inverter are supplied with English manual and English user menu.



**ACS150** with built-in display, potentiometer in the front and with fewer connection and programming options compared to the larger models.

It can be used for pressure regulation along with Geovent MultiBox III.

**ACH580** is the top model with assistant control panel as standard.

Has everything in programming and connections.

The models are available in different enclosures from IP20 to IP55 and in 1- or 3-phase versions.

If you have questions, we are ready to help.

# MULTIBOX

## PROVEN DESIGN

GEOVENT MultiBox III is a 5th generation control, based on the latest microprocessor technology.

## SEVERAL OPTIONS IN ONE BOX

GEOVENT MultiBox III can be used for pressure gauging, control, regulation and alarm surveillance in installations for process ventilation in the pressure range 10–5000 Pa.

## EASY TO USE

MultiBox III is particularly suitable for dynamic pressure regulation in installations with regulation dampers and/or with fans with frequency inverters.

The desired pressure or flow (differential pressure) is entered as set-point and the built-in regulator will adjust damper or frequency inverter. If the regulation does not maintain pressure or flow within the predefined limits, the alarm is activated.

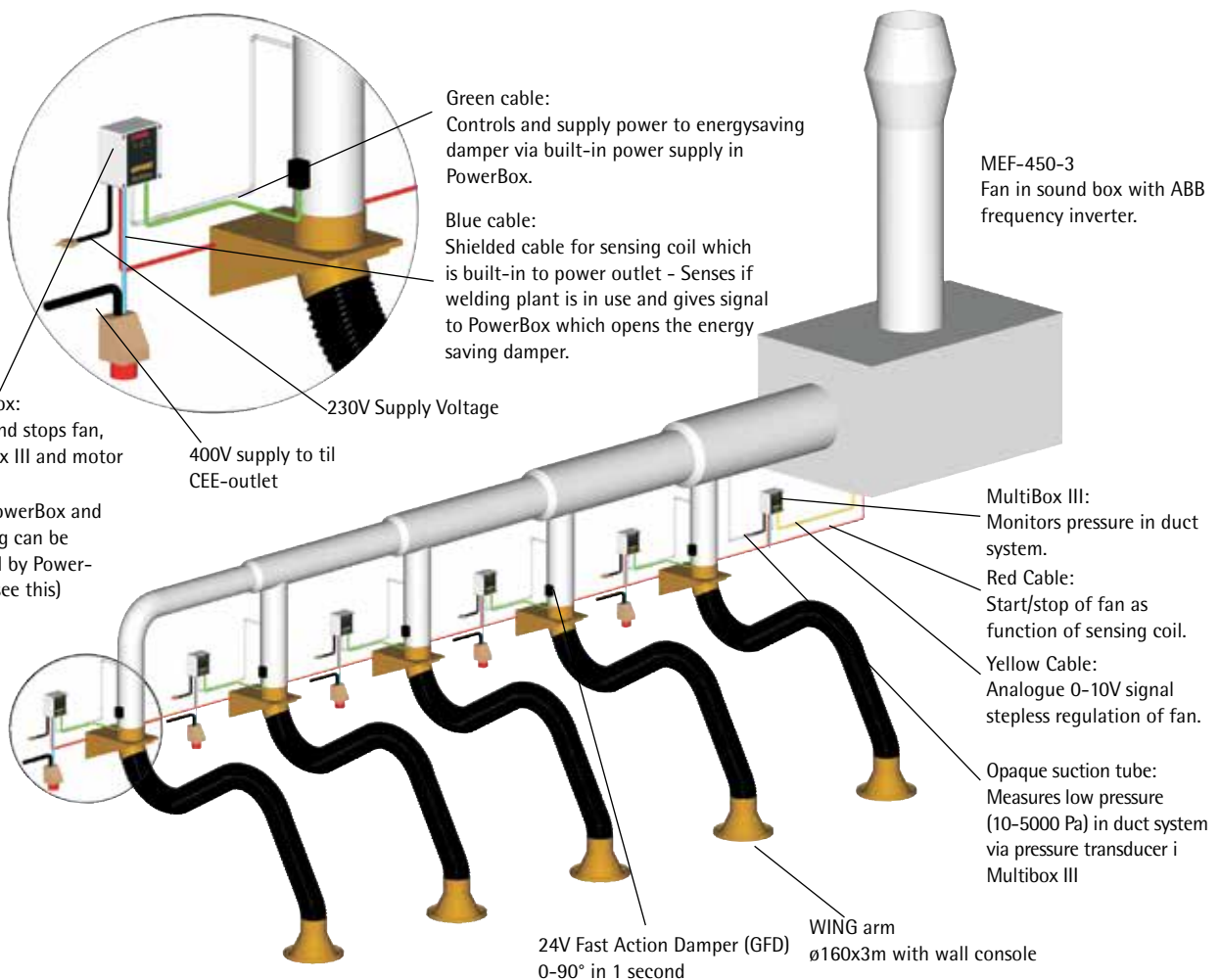



# Multicoupling diagram for switches, Multibox III and frequency inverters

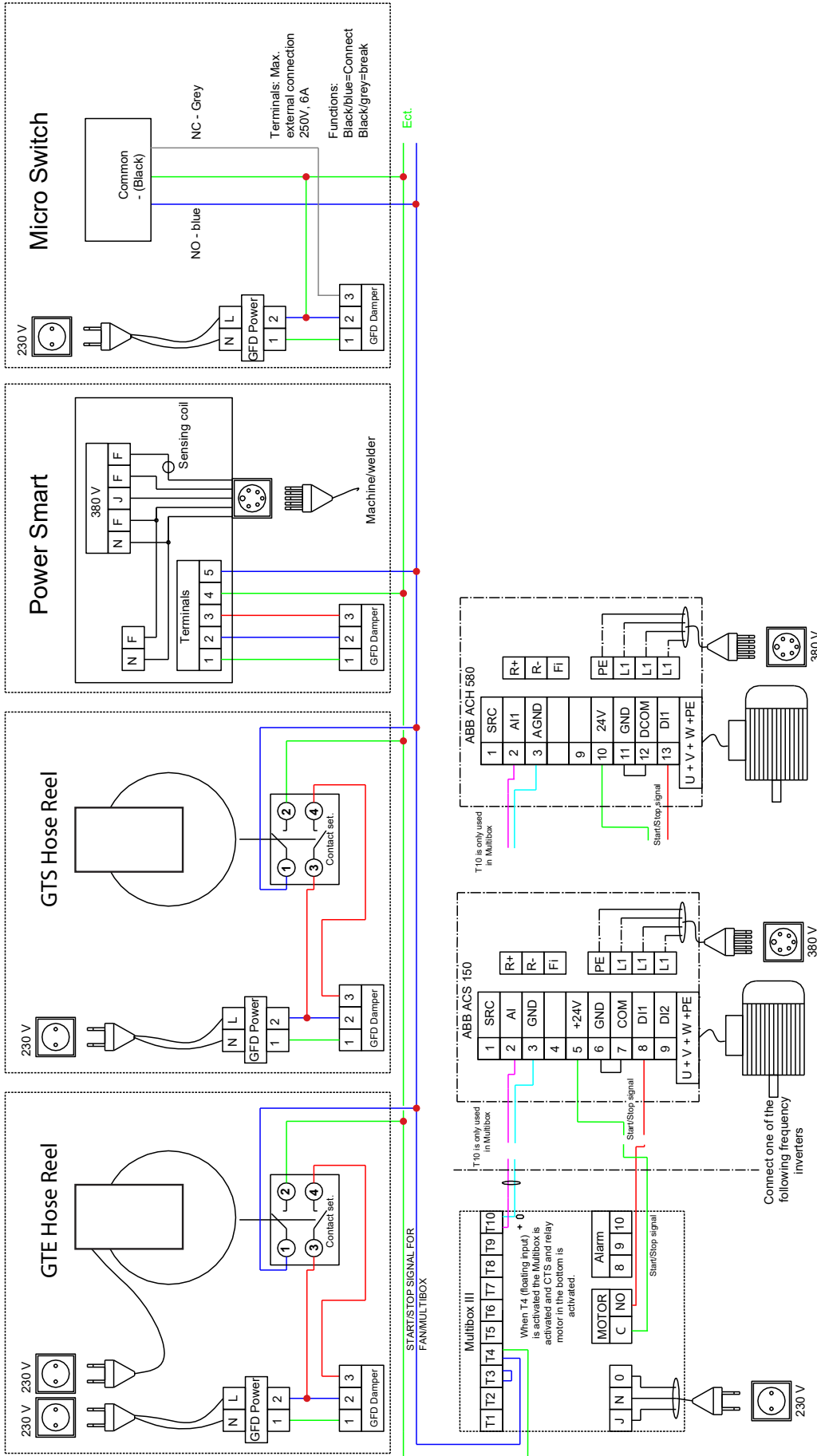

**Adjusting Multibox III:**  
 Quickguide - also see manual  
 P0: Version selector - select 530 (most common)  
 P1: Adjustment set point [Pa]  
 P2: Min. Alarm limits [s] at too low pressure  
 P3: Max. Alarm limit [s] at too high pressure  
 P10: Shows current pressure.

**OBS - IMPORTANT**  
 Jumper on the bottom (S1) must be switched from "I" to "U" This will change output from current to voltage.  
 Remember to bridge GND and COM.

**Adjusting frequency inverter:**  
 See manual - important parameters, must be adjusted:  
**Motor data:** Typically parameter group 99  
**Ramp up/down:** Typically parameter group 22  
**Frequency Max/Min:** Typically parameter group 20 and 11



Art. No.	Description
13-700	MultiBox III is suitable for pressure regulation (PID), measuring, control and monitoring (with alarm) of a system for process ventilation. Choose range: 10-1000Pa or 10-5000Pa. 3 outputs and 3 inputs in Sumbox. Capable of controlling several fans and regulate after 3 setpoints. Including service alarm, red alarm light and siren.



13-710	AirBox III 10-5000 Pa ventilation monitor with built-in pressure transmitter, monitoring and alarm for process extraction. Complies with the requirements of the Danish Working Environment Authority. Including service alarm, red alarm light and siren.
--------	--



13-730	AirBox Lite 500-2000 Pa ventilation guard, monitoring and alarm for process extraction. Complies with the requirements of the Danish Working Environment Authority. Red and green control light, no siren.
13-728	AirBox Lite 20-300Pa.
13-729	AirBox Lite 100-1000Pa.
13-727	AirBox Lite HV 30kPa



13-102	Suction tube with mounting kit - 10 m ø6 mm
--------	---



13-080	Red external alarm light 1x230V
13-081	External siren 1x230V - 100 dB(A)



PowerSmart II - for connection of welding plant. Sends a signal to the damper, when the welder is turned on. Incl. self-adjusting, active flux sensor = immune to noise. Suitable for new installations. 2 x relay output and 24V transformer.	
13-059	PowerSmart II CEE 16A
13-058	PowerSmart II CEE 32A
13-058A	PowerSmart II CEE 63A



PowerBox III - for start/stop of fan and GFD motor damper. The PowerBox is supplied with 3 inputs which can be connected to sensing coils. 18W 24V DC power supply for GFD motor damper.	
13-057	PowerBox III, sensing coil not included
13-047	Sensing coil for PowerBox. Register if welding plant, angle grinder or other equipment is in use and signals the PowerBox. The connected equipment must have a power consumption in excess of 700W.
13-047A	Flux sensor for PowerBox. Must be used with equipment that does not comply with the EMC Directive.





Control panel LWS-2 for automatic start/stop of fan incl. circuit breaker.  
Optionally supplied with built-in timer, so the fan can run after the start signal is shut off.

Art. No.	Description
19-080	Control panel LWS-2 0,2-1A
19-081	Control panel LWS-2 0,2-1A with transformer and timer delay
19-082	Control panel LWS-2 1-5A
19-083	Control panel LWS-2 1-5A with transformer and timer delay
19-084	Control panel LWS-2 3,2-16A
19-085	Control panel LWS-2 3,2-16A with transformer and timer delay

Fan starter incl. motor guard and 24V power supply

External ABB frequency inverters



Affordable external frequency inverter incl. EMC radio noise filter.  
Built-in display and pot meter in front.

Art. No.	Description
19-160	ACS 150 1x230V 0,37kW IP20
19-161	ACS 150 1x230V 0,75kW IP20
19-162	ACS 150 1x230V 1,1kW IP20
19-163	ACS 150 1x230V 1,5kW IP20
19-164	ACS 150 1x230V 2,2kW IP20
19-165	ACS 150 3x380-480V 0,37kW IP20
19-166	ACS 150 3x380-480V 0,55kW IP20
19-167	ACS 150 3x380-480V 0,75kW IP20
19-168	ACS 150 3x380-480V 1,1kW IP20
19-169	ACS 150 3x380-480V 1,5kW IP20
19-170	ACS 150 3x380-480V 2,2kW IP20
19-171	ACS 150 3x380-480V 3,0kW IP20
19-172	ACS 150 3X380-480V 4,0kW IP20

External ABB frequency inverters



High End external frequency inverter incl. EMC radio noise filter, incl. Assistant control panel

Art. No.	Description
19-450	ACH 580 3X380-480V 0,75kW IP55
19-451	ACH 580 3X380-480V 1,1kW IP55
19-452	ACH 580 3X380-480V 1,5kW IP55
19-453	ACH 580 3X380-480V 2,2kW IP55
19-454	ACH 580 3X380-480V 3kW IP55
19-455	ACH 580 3X380-480V 4kW IP55
19-456	ACH 580 3X380-480V 5,5kW IP55
19-457	ACH 580 3X380-480V 7,5kW IP55
19-458	ACH 580 3X380-480V 11kW IP55
19-459	ACH 580 3X380-480V 15kW IP55
19-460	ACH 580 3X380-480V 18,5kW IP55
19-461	ACH 580 3X380-480V 22kW IP55

## Accessories for ABB frequency inverters



Art. No.	Description
97-002	External pot meter 10 k $\Omega$ . Speed adjustment 0-100%
19-285	Steel wall cupboard for ACS150 400x300x200mm. (HxWxD) With noise insulation for the frequency inverter. Incl. cooling fan and mesh.

## GeoDrive



Small range external frequency inverter, IP54, for control of AC motors.  
Connection: 1x230V or 3x230V 50Hz, input. To be controlled via 0-10V signal.

Art. No.	Description
19-300	GeoDrive E1045 - 0,37kW
19-301	GeoDrive E1045 - 0,75kW
19-302	GeoDrive E1045 - 1,5kW

## Motor damper ( 0 to 90° = 1 sec.)



Art. No.	Description
61-091	Motor damper GFD-80
61-092	Motor damper GFD-100
61-093	Motor damper GFD-125
61-094	Motor damper GFD-160
61-095	Motor damper GFD-200
61-096	Motor damper GFD-250

Quick action: on/off or modulating



61-046	Power supply 230V / 24V for GFD Motor Damper
--------	--

# HIGH VACUUM UNIT



Geovent High Vacuum Unit can be supplied as a complete unit, as separate modules, stationary or mobile. Geovent HVU is ideal when particles are to be removed from the polluting process, for example vacuuming and grinding jobs in the industry, repair shops or hotels where the separated particles must be collected and disposed of.

Geovent High Vacuum Unit is produced with high quality European components and is supplied complete with filter cartridge and filter cyclone, cleaning system with compressed air and available with customized controls.

Geovent's modular High Vacuum system is customized and designed specifically for the application. Typically a High Vacuum System consists of:

HVU Solo,  
Filter cyclone,  
Control panel

A pre-separator can be added to separate the largest particles before it reaches the filter cartridge.

Geovent carry a wide range of accessories for our High Vacuum Units including hoses, tubes, valves and energy satellites.

HVU Solo. Stand-alone motor-module.





# HIGH VACUUM UNIT

## Energy arm

Geovent Energy arm is used where power, compressed air and extraction is needed at the workplaces, as well as where flexibility is required.

Geovent Energy arm is delivered as standard with 4 meters (03-680) or 6 meters arm (03-681), spring balancer and two 2 tool hangers, 1 x  $\varnothing 50$  mm high vacuum outlet (AD50 valve w. flap), 2 pcs. 230V, 1 pc. 3x400V 16A power outlet, 1 on/off button and 2 compressed air outlets. All connections are gathered in  $\varnothing 125$  mm flex hose.

Geovent Energy arm can be made customized.



## HVU high vacuum description

The side channel blower is placed inside a galvanized sound proof enclosure. The unit will be delivered as standard with control panel, filter cyclone, inlet filters and safety valve.

The HVU is delivered as standard for indoor use. The cabinet can upon request be sound proofed inside and is as standard provided with a gate for easy access to service. Motor cooling takes place via ventilation holes in the cabinet.

The heart of the HVU unit is a European produced side channel blower, which as standard can be delivered from 5,5 to 15 kW. In special needs we can deliver up to 20 kW.

The HVU can be upgraded with a "police filter" which protects the side channel blower from dust that is not caught by the main filter (fx. cleaning or leakage).

The control unit is delivered in a separate lacquered steel cabinet and is supplied with automatic start/stop function as standard. The start/stop function is activated via the micro-controller on the outlet valves or external contacts. Standard control panel is delivered for 3x400V, 50Hz and can be delivered with built-in frequency inverter and PLC at extra cost, customized for the task.

## HVU Lite - 99,9% filtration efficiency and automatic pneumatic filter cleaning



Complete High Vacuum Unit with filter cyclone for extraction of dust from grinding processes, brake dust and work station cleaning. The unit is supplied with 99,9% antistatic filter cartridge of 5m<sup>2</sup>, collection bucket of 18 litres, start/stop control and automatic cleaning. HVU Lite is suitable for use in up to 6 hours a day from 1 - 4 outlets.

Art. No.	Description	[kW]	[Volt]	[m <sup>3</sup> /h v/ 0 Pa	[kPa] Max
03-840	HVU Lite 55 STD With fully automatic pneumatic cleaning, automatic start/stop control panel and vacuum protection for side channel blower (overload protection).	5,5	3 x 400	500	22,5 kPa
03-841	HVU Lite 55 FRQ With fully automatic pneumatic cleaning, automatic start/stop, frequency inverter and vacuum protection for side channel blower (overload protection).	5,5	3 x 400	500	22,5 kPa

Dimensions: HxWxD = 1200 x 550 x 1000 mm

Connection: ø76 mm inlet on the front of the cyclone / ø76 mm outlet on the top.  
Noise level: 74db(A)

Compressed air: 3,5 - 5 bar clean and dry air.

Model	HVU-Lite
Power [kW]	5,5
Power consumption 100% load	13,0 A
Max. air flow	500
Max vacuum [kPa]	22,5
Filter surface area [m <sup>2</sup> ]	5
Filtration level acc. to BIA-test [%]	99,9
Sound pressure level	74dBA
Compressed air tank [litres]	4
Collection bucket [litres]	12
Cabinet + cyclone ø700 mm	Powder coated
Corrosion class (indoor)	II
Weight [kg]	140
øD	76
ød	76

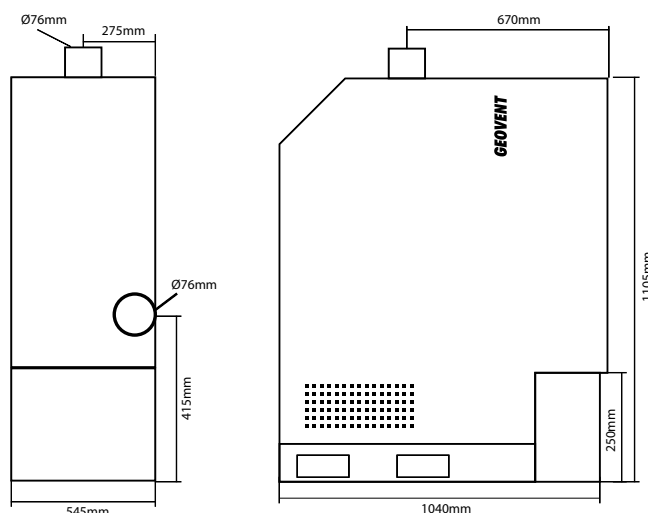

HVU-Lite Dimensions

## HVU - w. fully automatic pneumatic filter cleaning, at 99,9% efficiency



Geovent high vacuum unit HVU (over 20 kPa). Suitable for vacuuming at pre-sale preparation of cars, grinder dust or in connection with energy arms.

The unit is supplied with a two-step filter cyclone with an efficiency of 99,9% and fully automatic pneumatic filter cleaning.

Complete with control panel for automatic start/stop, and vacuum protection. The HVU is suitable for intensive use - up to 8-10 hours a day and can be connected to up to 12 outlets.

Art. No.	Description	[kW]	[Volt]	[m <sup>3</sup> /h v/ 0 Pa	[kPa] Max
03-652	HVU-7 Complete unit 3x400V	7,5	3x400v	700	27 kPa
03-653	HVU-11 Complete unit 3x400V	11	3x400v	1200	18,5 kPa
03-654	HVU-15 Complete unit 3x400V	15	3x400v	1200	31,5 kPa

Available with demand control upon request.

Note: All HVU-units are available with frequency inverter for increased performance. See dotted curves (60Hz).

## Data for HVU



Model	HVU-7	HVU-11	HVU-15
Power [kW]	7,5	11	15
Power consumption 100% load	16,7 A	26,2 A	32,0 A
Max. air flow	700	1200	1200
Max vacuum [kPa]	27	18,5	31,5
Filter surface area [m <sup>2</sup> ]	12	12	12
Filtration level acc. to BIA-test [%]	99,9	99,9	99,9
Sound pressure level	74 dBA	75 dBA	76 dBA
Compressed air tank [litres]	4	4	4
Collection bucket [litres]	34	34	34
Cabinet + cyclone ø700 mm	Powder coated	Powder coated	Powder coated
Corrosion class (indoor)	II	II	II
Weight [kg]	261	307	328
øD	127	127	127
ød	127	127	127

### HVU Dimensions

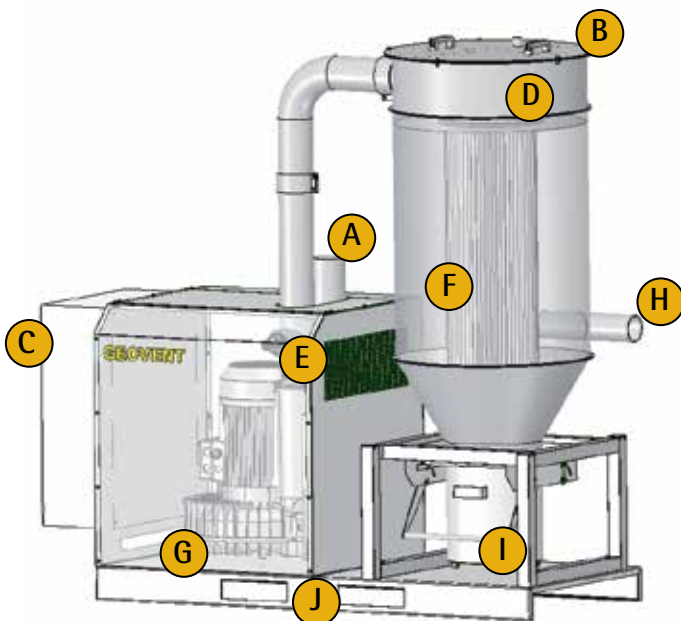
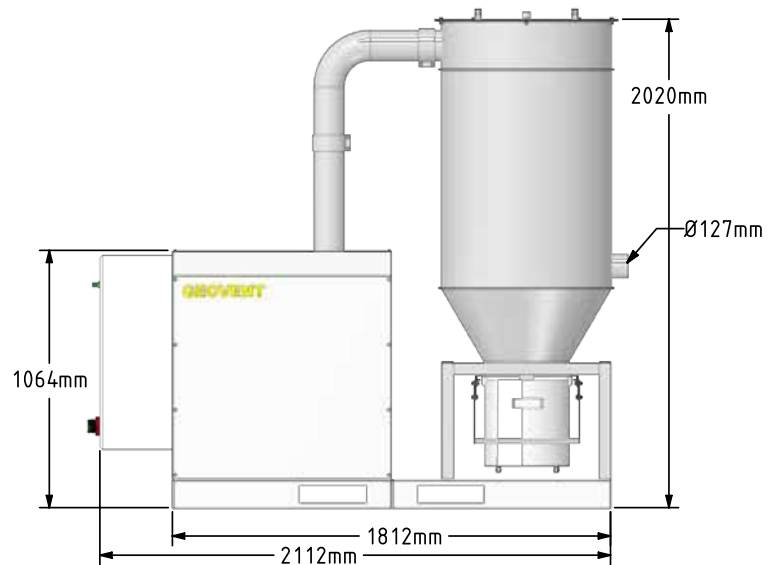
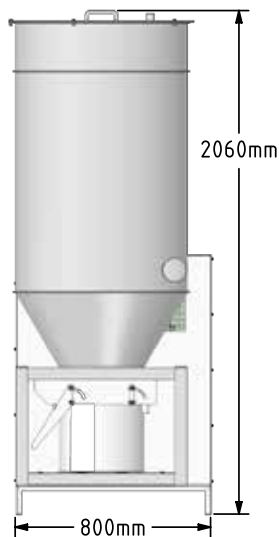

- A Ø127 mm Outlet
- B Removable top
- C Control panel with automatic start/stop and filter cleaning
- D Pneumatic cleaning system
- E Safety valve
- F Filter cartridge - alu-coated polyester tissue - antistatic
- G Shield for side channel blower
- H Ø127 mm inlet
- I Collection bucket 34 litres
- J Frame with holes for forklift truck

# Pressure drop for Geovent HVU

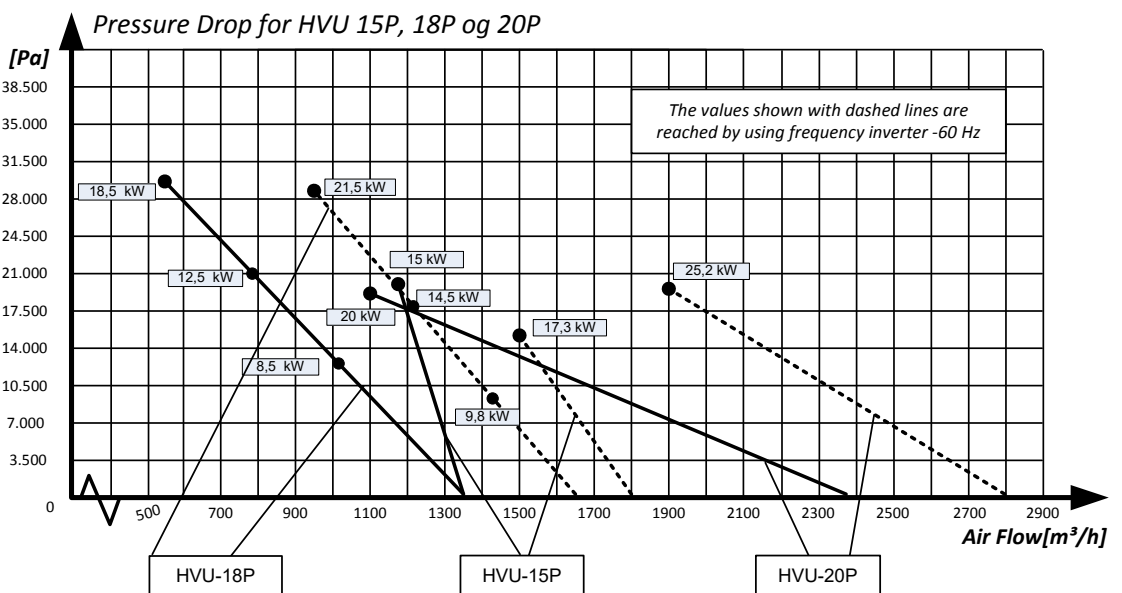
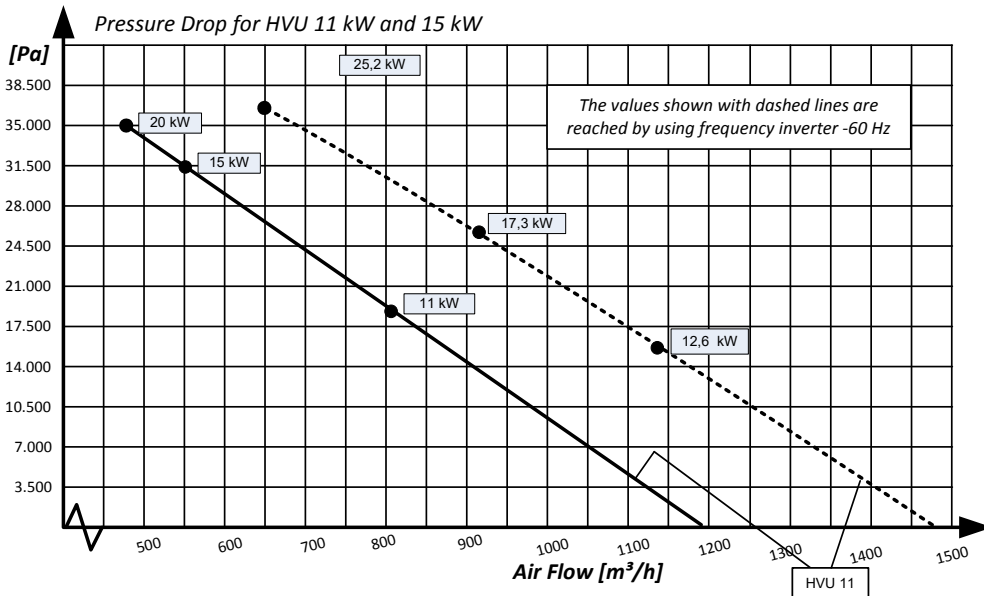
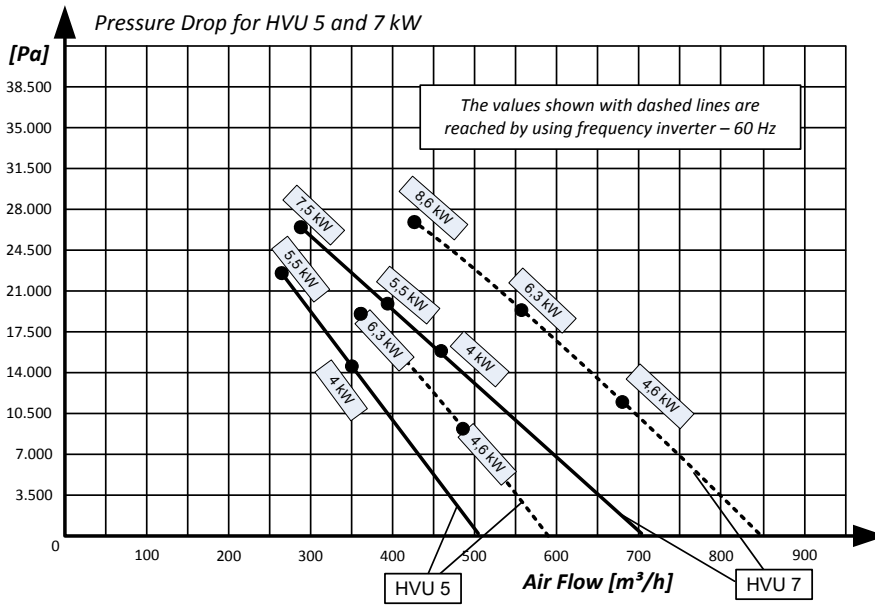

## HVU-IT - integrated demand control and cleaning, 99,9% at 0,3µm



Geovent High Vacuum Unit HVU-IT is for example used for central vacuum cleaning in hotels. This version comes with a two-step filter cyclone with a 5 m<sup>2</sup> filter cartridge and efficiency up to 99,9% and fully automatic pneumatic filter cleaning. Complete with control board with built-in frequency inverter and PLC, for automatic start/stop and demand control.

Blow-out to clean tube system and level indicator.

The side channel blower is equipped with vacuum protection and temperature protection.

Noise insulated cabinet for indoor placement. The HVU-IT is suitable for intensive use and can be connected to up to 12 outlets.

Art. No.	Description	[kW] 50Hz/60Hz	[Volt]	[m <sup>3</sup> /h] v/ 0 Pa	[kPa] Max
03-851	HVU-IT-5 Complete unit	5,5/6,3	3x400V	590	22 kPa
03-852	HVU-IT-7 Complete unit	7,5/8,6	3x400V	850	27 kPa
03-853	HVU-IT-11 Complete unit	11/12,6	3x400V	1475	19 kPa
03-854	HVU-IT-15 Complete unit	15/17,3	3x400V	1475	31 kPa

## HVU Solo - stand alone module with side channel blower



Geovent High Vacuum Unit for flexible placement.

The side channel blower is equipped with vacuum protection.

Art. No.	Description	[kW]* 50Hz/60Hz	[Volt]	[m <sup>3</sup> /h] v/ 0 Pa	[kPa] Max
03-951	HVU Solo 5	5,5/6,3	3x400V	590	22 kPa
03-952	HVU Solo 7	7,5/8,6	3x400V	850	27 kPa
03-953	HVU Solo 11	11/12,6	3x400V	1475	19 kPa
03-954	HVU Solo 15	15/17,3	3x400V	1475	31 kPa
03-941	HVU Solo 18 Performance	18,5/21,5	3x400V	1.350	31 kPa
03-942	HVU Solo 20 Performance	20/25,2	3x400V	2.200	18,5 kPa

\* 60Hz requires control board with frequency inverter

HVU Solo is available in a version with increased performance - up to 2800m<sup>3</sup>/h.

Enquire at Geovent.

## HVU Filter cyclone



Separate filter cyclone for HVU Solo. The unit is equipped with a two-step filtering through cyclone and filter cartridge. 99,9% efficient.

Shot valves for cleaning the filter cartridge.

Art. No.	Description	Diameter	Connection	Filter Area
03-956	Filter cyclone 11-15	ø450 mm	ø127 mm	5 m <sup>2</sup>
03-956A	Filter cyclone 11-15	ø700 mm	ø127 mm	12 m <sup>2</sup>

Control not included

## HVU Control boards



Available in 2 versions: STD and FRQ.

STD with automatic, pneumatic filter cleaning and automatic start/stop.

FRQ come with built-in frequency inverter for demand control, automatic, pneumatic filter cleaning and automatic start/stop.

Art. No.	Description
19-133	HVU ST 5 STD For HVU Solo 5 and 7, with direct start
19-131	HVU ST 11 STD For HVU Solo 11 and 15, with soft-starter
19-120	HVU ST 5 FRQ
19-121	HVU ST 7 FRQ
19-122	HVU ST 11 FRQ
19-123	HVU ST 15 FRQ



## HVU - accessories for units



Art. No.	Description
03-963	Sound insulation Solo cabinet
03-812	Police filter HVU 5
03-813	Police filter HVU 7
03-814	Police filter HVU 11-15
03-957	Pre-seperator HVU 5-7 ø450 mm
03-958	Pre-seperator HVU 11-15 ø450 mm
03-958A	Pre-seperator HVU 11-15 ø700 mm
20-032	Bin sensor, placed inside cyclone. Senses when the bin is full, and sends signal to the control panel. ATEX rated as standard.

## Accessories for cyclone for High Vacuum Units



Art. No.	Description
03-966	Empty system with hatch. Pneumatic driven hatch, opens once the cleaning system is done cleaning. Steel construction 50x50 mm painted steel. Excl. control panel.
03-967	Empty system with double cut dampers. Steel construction 50x50 mm painted steel.
03-968	Longopac solution, including mounting console - 700x700x2497 mm. Steel construction 50x50 mm painted steel, with manual damper, makes it easy to empty the cyclone, without ever getting in contact with the material. Includes a pack of longopac endless bags.

## Accessories



Longopac bag

Big bag

Art. No.	Description
03-968-B	Longopac bag, Maxi Strong ESD
03-965-A	Big bag - 91x91x104 cm. SWL 1500 kg.

## Dimensions

Pneumatic driven hatch

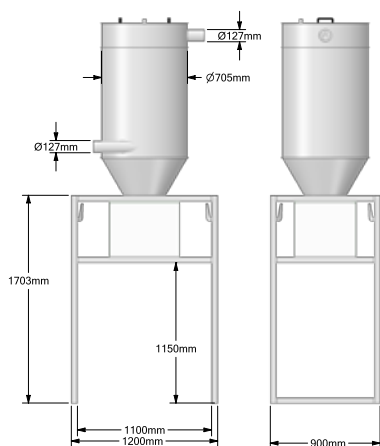

Double cut damper

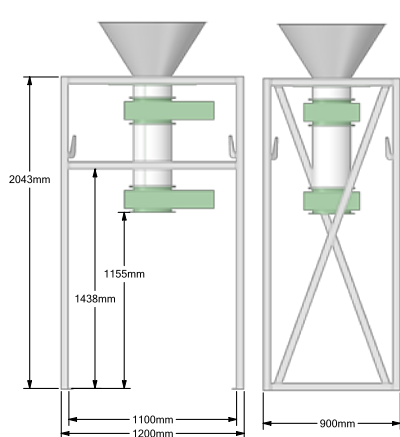

Longopac solution

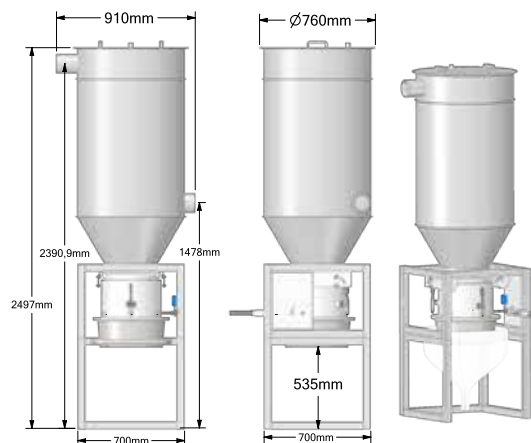



**Art. No. Description**

Hose reel for high vacuum. When not in use the hose is reeled in to the reel. The hose reel has an automatic damper which opens when the hose is pulled out and a micro switch for start/stop of the unit. By default supplied with antistatic hose and pivotable mounting bracket. Wall or ceiling mounting. Connection  $\varnothing$ 50 mm.

74-051	Hose reel with 9 m, $\varnothing$ 38 mm hose
74-052	Hose reel with 7 m, $\varnothing$ 50 mm hose



74-480	ASA-HV50 arm for high vacuum 2m, $\varnothing$ 50 mm
74-481	ASA-HV50 arm for high vacuum 3m, $\varnothing$ 50 mm
74-482	ASA-HV50 arm for high vacuum 4m, $\varnothing$ 50 mm
74-483	Mini-HV50 arm for high vacuum 1m, $\varnothing$ 50 mm
74-484	Mini-HV50 arm for high vacuum 1,5m, $\varnothing$ 50 mm
74-485	Muffled HV hood with magnet



01-130HV	Extension arm ASA HV 2m $\varnothing$ 50
01-131BHV	Extension arm ASA HV 4m $\varnothing$ 50, 2 joint
01-131HV	Extension arm ASA HV 4m $\varnothing$ 50, 1 joint



03-259	Replacement cartridge $\varnothing$ 315 mm, HVU and HVU Filter cyclone. 12 m <sup>2</sup> - alu coated polyester
03-260	Replacement cartridge $\varnothing$ 260 mm for HVU-Lite 5,4m <sup>2</sup> alu coated polyester.
03-685	Energy satellite with $\varnothing$ 80 mm high vacuum outlets, $\varnothing$ 150 mm low vacuum outlet, 1 pc. 400V and 2 pcs. 230V power outlets and 2 compressed air outlets. Customizable.
03-680	Energy arm 4m with 2 tool hangers, 1 x $\varnothing$ 50 mm high vacuum outlet AD50 with flap, 2 pcs. 230V and 1 pc. 400V 16 amp. power outlets. On/off button and 2 outlets for compressed air. Connection on duct side is put together in a $\varnothing$ 125 mm flex hose. Equipped with spring balancer. Customizable.
03-681	As above but 6 meter



Energy arm 4m. Art. No. 03-680

## Accessories for HVU



Art. No.	Description
----------	-------------

74-058	Hose cart for high vacuum hose, with 2 connected hose reels, each with 9 m $\varnothing$ 38 mm hose. Total range is approx 18 m
74-060	Complete industrial vacuuming set $\varnothing$ 32 mm for high vacuum: -Floor brush -Telescopic tube and handle with 10,5 m hose $\varnothing$ 32 mm -Round brush -Pointed mouth piece -Furniture mouth piece -Basket for accessories and hose holder -Start/Stop button in handle

## Accessories for HVU, $\varnothing$ 38 mm



Art. No.	Description
----------	-------------

74-502	Floor brush mouth piece for industrial use, metal, $\varnothing$ 38 mm
74-504	Brush mouth piece, $\varnothing$ 38 mm
74-505	Slit mouth piece, $\varnothing$ 38 mm
74-500	Tube for floor brush. One set = 1 bend and 1 two-piece tube
74-501	Steel tube, two-piece
74-501	Steel bend $\varnothing$ 38 mm
74-506	Hose connector $\varnothing$ 38 mm for GeoFlex High $\varnothing$ 38 mm. Fits $\varnothing$ 38 mm steel tube

## Accessories for HVU, $\varnothing$ 50 mm



Art. No.	Description
----------	-------------

74-552	Floor brush mouth piece for industrial use, metal, $\varnothing$ 50 mm
74-553	Slit mouth piece, $\varnothing$ 50 mm
74-550	Tube for floor brush. One set = 1 bend and 1 two-piece tube
74-550	Steel tube, two-piece, $\varnothing$ 50 mm
74-551	Steel bend $\varnothing$ 50 mm
74-554	Hose connector $\varnothing$ 50 mm for GeoFlex High $\varnothing$ 50 mm. Fits $\varnothing$ 50 mm steel tube

## Accessories for HVU



Art. No.	Description
----------	-------------

74-077	Hose holder for wall
05-122	AD50 flap valve, glass reinforced nylon, without microswitch
74-081	AD50 flap valve, glass reinforced nylon, with microswitch
74-082	Outlet $\varnothing$ 50 mm with AD50 flap valve. Galvanized tube and wall bracket. With microswitch. For $\varnothing$ 50 mm tube.
74-101	Double outlet w. 2xAD50 flap valve and wall bracket. Powder coated. For $\varnothing$ 100 mm tube. Additional charge for micro switch applies.
05-123	AKV universal adapter (male) for AD50. Suits hose $\varnothing$ 25- $\varnothing$ 45
05-127	AKV adapter (male) for AD50. Suits hose $\varnothing$ 50
05-128	AKV hose reduction, $\varnothing$ 25 => $\varnothing$ 32 => $\varnothing$ 38 => $\varnothing$ 45 => $\varnothing$ 50



Flap valve



Couplings



Compressed air damper



Branch pipe

### Accessories for HVU

Art. No.	Description
74-600	Metal flap valve $\varnothing 50\text{-}\varnothing 50$
74-601	Metal flap valve $\varnothing 63\text{-}\varnothing 50$
74-602	Metal flap valve $\varnothing 63\text{-}\varnothing 63$
74-603	Metal flap valve $\varnothing 76\text{-}\varnothing 63$
74-604	Metal flap valve $\varnothing 76\text{-}\varnothing 76$

74-610	Metal flap valve $\varnothing 50\text{-}\varnothing 50$ w/microswitch
74-611	Metal flap valve $\varnothing 63\text{-}\varnothing 50$ w/microswitch
74-612	Metal flap valve $\varnothing 63\text{-}\varnothing 63$ w/microswitch
74-613	Metal flap valve $\varnothing 76\text{-}\varnothing 63$ w/microswitch
74-614	Metal flap valve $\varnothing 76\text{-}\varnothing 76$ w/microswitch

74-620	Hose coupling $\varnothing 50\text{-}\varnothing 38$ for metal flap valve $\varnothing 50$ and hose $\varnothing 38$
74-622	Hose coupling $\varnothing 50\text{-}\varnothing 50$ for metal flap valve $\varnothing 50$ and hose $\varnothing 50$
74-623	Hose coupling $\varnothing 63\text{-}\varnothing 50$ for metal flap valve $\varnothing 63$ and hose $\varnothing 50$
74-624	Hose coupling $\varnothing 63\text{-}\varnothing 63$ for metal flap valve $\varnothing 63$ and hose $\varnothing 63$
74-625	Hose coupling $\varnothing 76\text{-}\varnothing 50$ for metal flap valve $\varnothing 76$ and hose $\varnothing 50$

74-640	Connection piece $\varnothing 50$ for 2 hose couplings
74-641	Connection piece $\varnothing 63$ for 2 hose couplings
74-642	Connection piece $\varnothing 76$ for 2 hose couplings

74-660	Compressed air damper $\varnothing 50$ mm
74-661	Compressed air damper $\varnothing 63$ mm
74-662	Compressed air damper $\varnothing 76$ mm
74-663	Compressed air damper $\varnothing 102$ mm
74-664	Compressed air damper $\varnothing 127$ mm
74-665	Compressed air damper $\varnothing 152$ mm

74-670	Manual slide damper $\varnothing 50$ mm
74-671	Manual slide damper $\varnothing 63$ mm
74-672	Manual slide damper $\varnothing 76$ mm
74-673	Manual slide damper $\varnothing 102$ mm
74-674	Manual slide damper $\varnothing 127$ mm
74-675	Manual slide damper $\varnothing 152$ mm

### Duct and fittings high vacuum

Art. No.	Description
74-680	Manual slide damper w/ microswitch $\varnothing 50$ mm
74-681	Manual slide damper w/ microswitch $\varnothing 63$ mm
74-682	Manual slide damper w/ microswitch $\varnothing 76$ mm
74-683	Manual slide damper w/ microswitch $\varnothing 102$ mm
74-684	Manual slide damper w/ microswitch $\varnothing 127$ mm
74-685	Manual slide damper w/ microswitch $\varnothing 152$ mm

74-270	Galvanized pipe $\varnothing 50$ mm, length=3000 mm
74-270L	Galvanized pipe $\varnothing 50$ mm, length=6000 mm
74-271	Galvanized pipe $\varnothing 63$ mm, length=3000 mm
74-271L	Galvanized pipe $\varnothing 63$ mm, length=6000 mm
74-272	Galvanized pipe $\varnothing 76$ mm, length=3000 mm
74-272L	Galvanized pipe $\varnothing 76$ mm, length=6000 mm
74-273	Galvanized pipe $\varnothing 102$ mm, length=3000 mm
74-273L	Galvanized pipe $\varnothing 102$ mm, length=6000 mm
74-274	Galvanized pipe $\varnothing 127$ mm, length=3000 mm
74-274L	Galvanized pipe $\varnothing 127$ mm, length=6000 mm
74-274A	Galvanized pipe $\varnothing 152$ mm, length=3000 mm
74-274AL	Galvanized pipe $\varnothing 152$ mm, length=6000 mm
74-274B	Galvanized pipe $\varnothing 203$ mm, length=3000 mm
74-274BL	Galvanized pipe $\varnothing 203$ mm, length=6000 mm

74-275	Branch pipe 50/50 mm 45°, galv. length=300mm
74-276	Branch pipe 63/63 mm 45°, galv. length=300mm
74-277	Branch pipe 63/50 mm 45°, galv. length=300mm
74-278	Branch pipe 76/76 mm 45°, galv. length=300mm
74-279	Branch pipe 76/63 mm 45°, galv. length=300mm
74-280	Branch pipe 76/50 mm 45°, galv. length=300mm
74-284	Branch pipe 102/102 mm 45°, galv. length=300mm
74-283	Branch pipe 102/76 mm 45°, galv. length=300mm
74-282	Branch pipe 102/63 mm 45°, galv. length=300mm
74-281	Branch pipe 102/50 mm 45°, galv. length=300mm
74-450	Branch pipe 127/127 mm 45°, galv. length=300mm

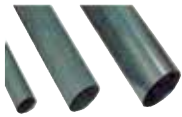

Ducts



Bends



Reductions



Connectors

### Duct and fittings high vacuum

Art. No.	Description
74-451	Branch pipe 127/102 mm 45°, galv. length=300 mm
74-452	Branch pipe 127/76 mm 45°, galv. length=300 mm
74-453	Branch pipe 127/63 mm 45°, galv. length=300 mm
74-454	Branch pipe 152/152 mm 45°, galv. length=300 mm
74-455	Branch pipe 152/127 mm 45°, galv. length=300 mm
74-456	Branch pipe 152/102 mm 45°, galv. length=300 mm
74-457	Branch pipe 152/76 mm 45°, galv. length=300 mm
74-458	Branch pipe 152/63 mm 45°, galv. length=300 mm
74-459	Branch pipe 203/127 mm 45°, galv. length=300 mm
74-459A	Branch pipe 203/152 mm 45°, galv. length=300 mm
74-459B	Branch pipe 203/203 mm 45°, galv. length=300 mm

74-264	Y pipe ø50 mm for high vacuum
74-265	Y pipe ø63 mm for high vacuum
74-266	Y pipe ø76 mm for high vacuum
74-267	Y pipe ø102 mm for high vacuum
74-268	Y pipe ø127 mm for high vacuum
74-269	Y pipe ø152 mm for high vacuum
74-269A	Y pipe ø203 mm for high vacuum

74-290	Bend ø76x45°, centre radius=160 mm
74-290A	Bend ø102x45°, centre radius=160 mm
74-290C	Bend ø127x45°, centre radius=160 mm
74-290D	Bend ø152x45°, centre radius=160 mm

74-285	Bend ø50x90°, centre radius=160 mm
74-286	Bend ø63x90°, centre radius=160 mm
74-287	Bend ø76x90°, centre radius=160 mm
74-287A	Bend ø102x90°, centre radius=160 mm
74-287C	Bend ø127x90°, centre radius=160 mm
74-287D	Bend ø152x90°, centre radius=160 mm
74-287E	Bend ø203x90°, centre radius=160 mm
74-288	Bend ø50x45°, centre radius=160 mm
74-289	Bend ø63x45°, centre radius=160 mm
74-290E	Bend ø203x45°, centre radius=160 mm

### Duct and fittings high vacuum

Art. No.	Description
74-291	Reduction 63-50
74-292	Reduction 76-63
74-293	Reduction 76-50
74-294A	Reduction 102-76
74-294	Reduction 102-63
74-460	Reduction 127-102
74-461	Reduction 127-76
74-462	Reduction 152-127
74-463	Reduction 152-102
74-464	Reduction 203-152

74-295	Pipe connection ø50 mm w/ antistatic seal
74-296	Pipe connection ø63 mm w/ antistatic seal
74-297	Pipe connection ø76 mm w/ antistatic seal
74-298	Pipe connection ø102 mm w/ antistatic seal
74-299	Pipe connection ø127 mm w/ antistatic seal
74-299A	Pipe connection ø152 mm w/ antistatic seal
74-299B	Pipe connection ø203 mm w/ antistatic seal

74-310	End cap ø50 mm
74-311	End cap ø63 mm
74-312	End cap ø76 mm
74-313	End cap ø102 mm
74-314	End cap ø127 mm
74-134A	End cap ø152 mm
74-314B	End cap ø203 mm

74-315	Suspension bracket for pipe connection
--------	--

All ducts and fittings are galvanized inside and outside.  
Duct and fittings are available in stainless steel - enquire.



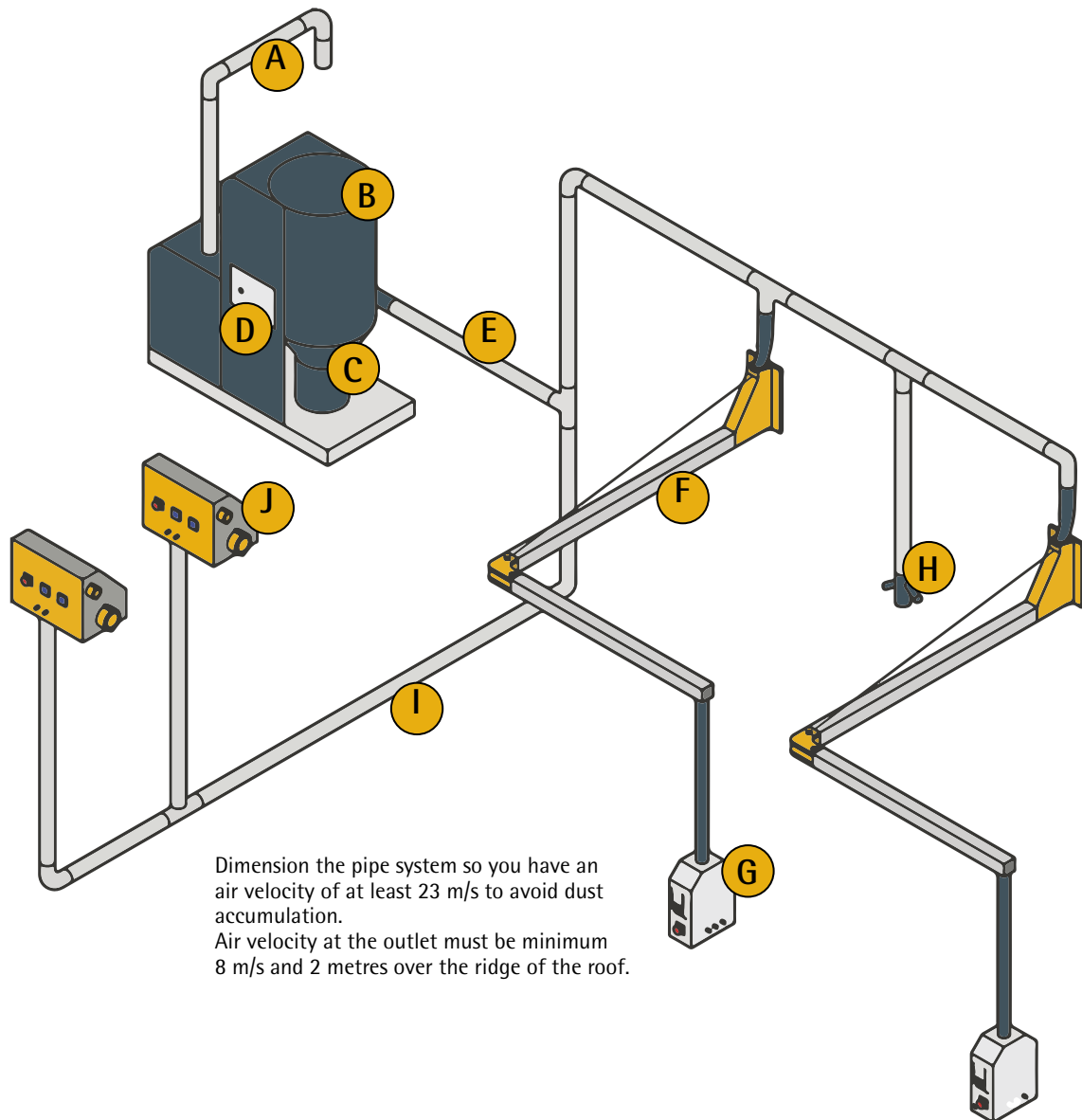

Dimension the pipe system so you have an air velocity of at least 23 m/s to avoid dust accumulation.  
Air velocity at the outlet must be minimum 8 m/s and 2 metres over the ridge of the roof.

**Description**

- A. Outlet - clean air
- B. High Vacuum Unit
- C. Filter cyclone with collection bucket
- D. Control panel with automatic start/stop
- E.  $\varnothing$ 125 mm High Vacuum pipes
- F. Extension arms 4 or 6 m.
- G. Energy console with 2 High Vacuum outlets.  
1 pc. 400V and 1 pc. 230V power outlet  
3 compressed air outlet with start/stop for High Vacuum unit. Customisable on request.
- H. 2  $\varnothing$ 50 mm High Vacuum outlets w/microswitch for start/stop of High Vacuum unit.
- I. Pipes below floor
- J. Energy satellite with  $\varnothing$ 80 mm High Vacuum outlets,  
 $\varnothing$ 150 mm Low Vacuum outlet, 1 pc. 400V and 2 pcs. 230V power outlet and 2 compressed air outlet.

**Application**

Grinding dust extraction from rotary and vibration sanders.  
Extraction of metal shavings from milling, turning and sawing processes.  
Ordinary work station cleaning.

# ATEX compliant products

All ATEX-products from Geovent are manufactured in compliance with the directive 2014/34/EU, earlier 94/9/EC. It is the responsibility of the individual employer to obtain zone-classifications in the company concerned, and often this is carried out in cooperation with local authorities or qualified consultants.

For further information regarding ATEX, please refer to local instructions for work in ATEX and explosive atmospheres.

European companies are obliged to assess whether there is a risk of explosion in connection with their production as a result of ignition of an atmosphere consisting of air mixed with flammable gases, vapours, fluids, mist/aerosole or flammable dust mists.

If there is a risk, the risk must be assessed as the foundation of a classification of the area(s) in danger of explosion. In addition to this, the company must take precautions in order to avoid explosions and to draw up documentation.

The central principle is to divide the company into zones on basis of the risk of explosion and its consequences. In this connection, it is necessary both to consider the type and the volume of leak, ventilation, safety systems and the potential ignition sources, as for instance electrostatic charge, electrical installations and mechanically generated sparks. The assessment is to apply to existing equipment as well as to new acquisitions of machinery and equipment.

A complete set of documentations are supplied with a Geovent ATEX product.



Zone	Description	Equipment	Geovent Equipment
0	Area, where constantly, frequently or for a longer period of time there is an explosive atmosphere, consisting of a mixture of air and flammable gas, vapours or mist.	Category 1 G (gas)	--
1	Area, where an explosive mixture of air and flammable gas, vapour or mist may occasionally occur, during normal operation.	Category 1 or 2 G (gas)	MSX/MEX fan
2	Area, where during normal operation an explosive atmosphere, consisting of a mixture of air with flammable gas, vapour or mist probably does not occur. However, if it occurs, it will only be for a short period of time.	Category 1, 2 or 3 G (gas)	MSX/MEX fan
20	Area, where constantly, frequently or for a longer period of time there may be an explosive atmosphere, consisting of a cloud of flammable dust and air.	Category 1 D (dust)	GFX filter
21	Area, where occasionally during normal operation an explosive atmosphere consisting of a cloud of flammable dust and air may occur.	Category 1 or 2 D (dust)	GFX filter
22	Area, where during normal operation an explosive atmosphere, consisting of a cloud of flammable dust and air may most probably not occur, and should it occur anyhow, it will only be for a short period of time.	Category 1, 2 or 3 D (dust)	GFX filter MSX/MEX fan

## LSX / MSX – ATEX fan with forward curved scirocco impeller

ATEX  
Compliant



Zone 1, 2 and 22

Art. No.	Description	[kW]	[A]	Max [m³/h]	Max [Pa]
37-010	LSX-146-3	0,25	0,90	700	160
37-020	MSX-146-3	0,50	1,30	900	620
37-030	LSX-180-3	0,37	1,08	1.080	230
37-040	MSX-180-3	0,50	1,30	1.670	950
37-050	LSX-200-3	0,55	1,5	1.500	320
37-060	MSX-200-3	1,10	2,60	2.100	1.450
37-070	LSX-225-3	1,35	3,20	3.200	450
37-080	MSX-225-3	1,85	4,00	2.450	1.500
37-090	LSX-250-3	2,00	4,20	3.150	470
37-100	MSX-250-3	3,30	6,60	3.160	1.800

Please state required zone when ordering

## LEX / MEX – ATEX fan with backward curved impeller

ATEX  
Compliant



Zone 1, 2 and 22

Art. No.	Description	[kW]	[A]	Max [m³/h]	Max [Pa]
37-510	LEX-250-3	0,25	0,90	700	230
37-520	MEX-250-3	0,37	1,08	1.800	1.200
37-530	LEX-315-3	0,25	0,90	1.450	360
37-540	MEX-315-3	0,75	1,80	2.850	1.330
37-550	LEX-355-3	0,25	0,90	2.250	425
37-560	MEX-355-3	1,85	4,00	4.350	1.550
37-570	LEX-400-3	0,37	1,08	1.080	500
37-580	MEX-400-3	4,10	8,10	6.300	2.150
37-590	LEX-450-3	0,75	1,90	4.700	700
37-591	MEX-450-3	5,50	10,40	9.000	2.600
37-592	MEX-500-3	7,50	13,70	11.400	3.350
37-595	LEX-560-3	3,60	8,1	8.100	1.000
37-596	MEX-560-3	18,50	33,00	18.000	4.500
37-593	LEX-630-3	3,60	8,1	8.100	1.600

Please state required zone when ordering

## Accessories for frequency inverter operation

Art. No	Description
19-287	Thermistorrelay used between ATEX motor and frequency inverter

## Pressure drop curves for ATEX fan LSX/MSX 146 to 250

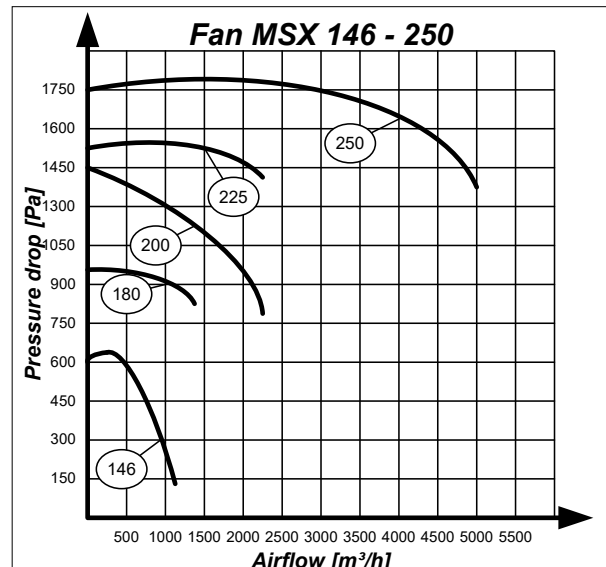
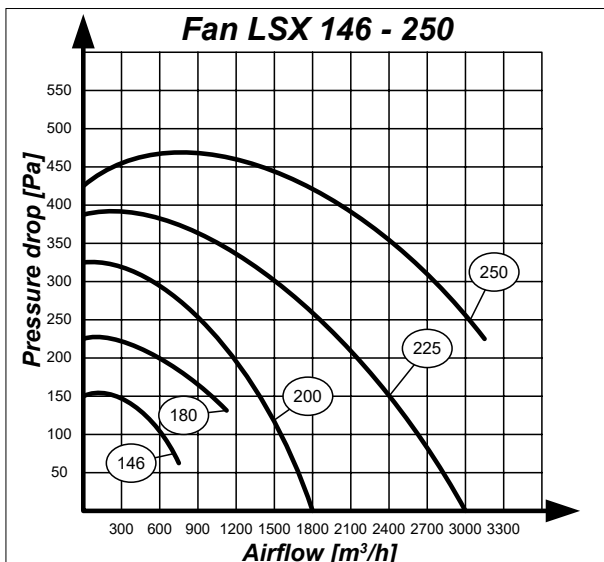

Pressure drop curves for ATEX fan LEX/MEX 250 to 355

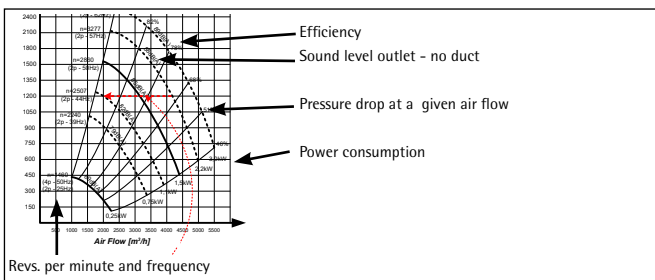
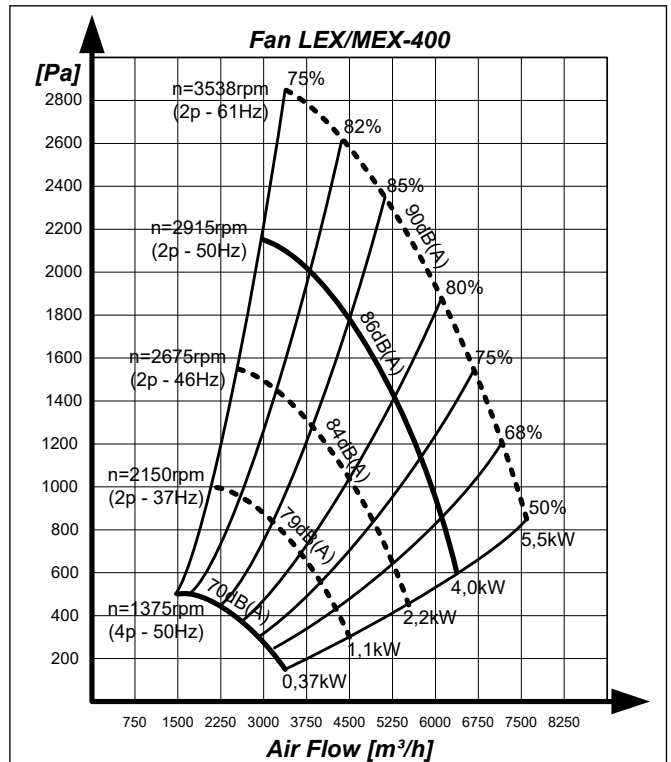
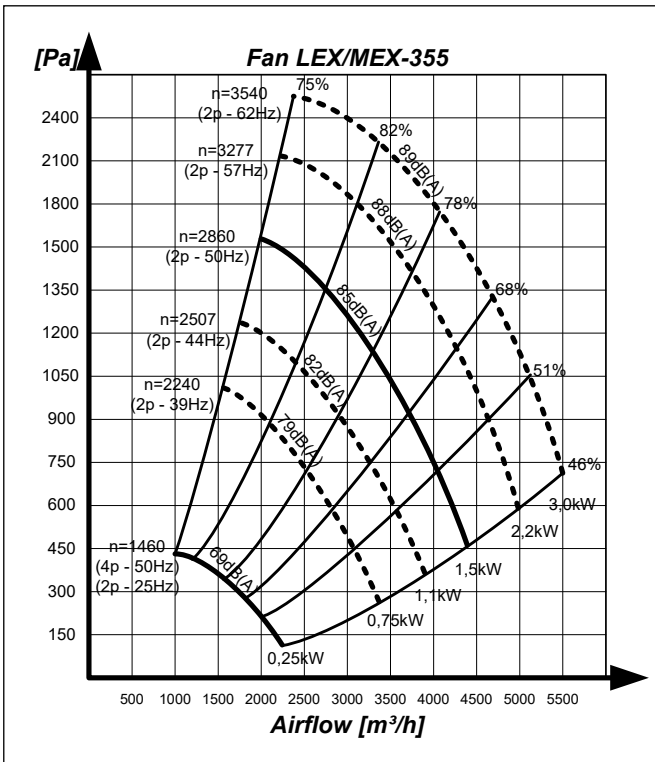
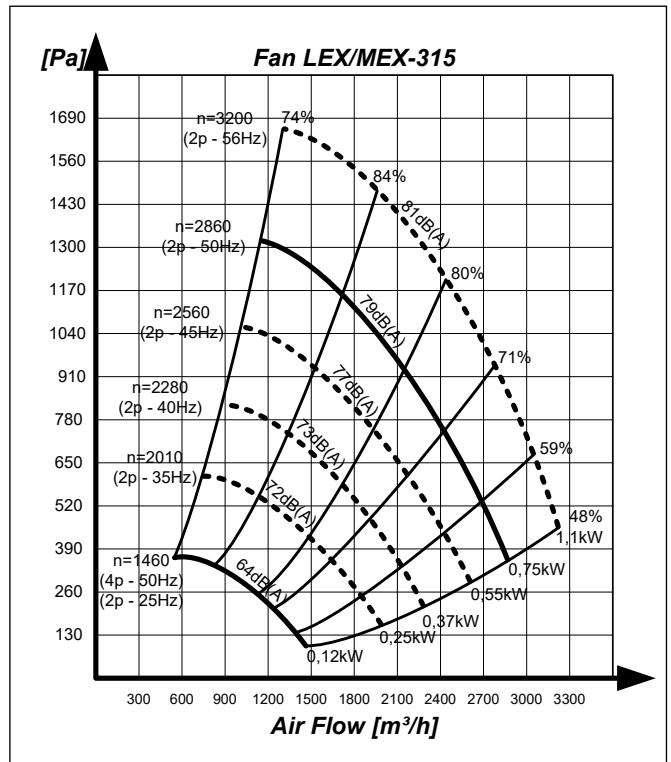
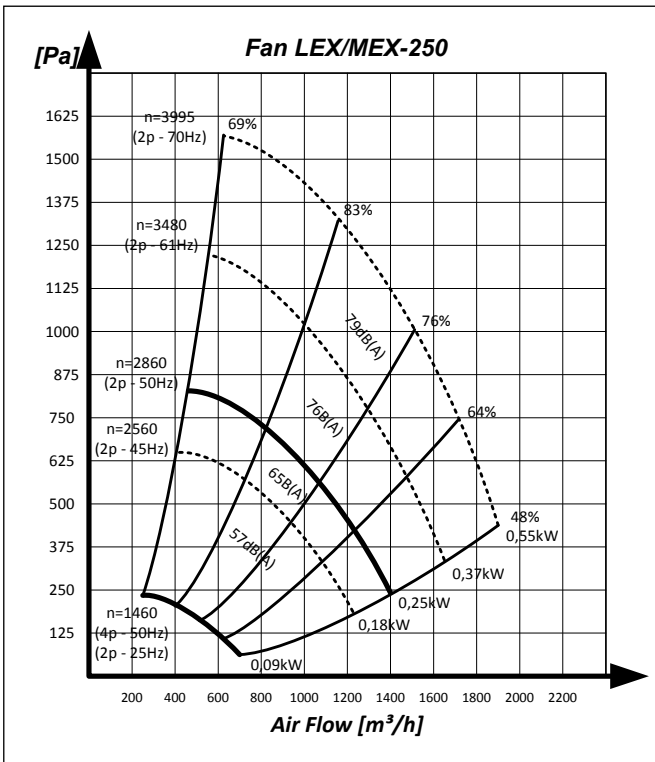

**Dashed line = Requires specially adjustable motor.**

**Contact Geovent for further information.**

Pressure drop curves for ATEX fan LEX/MEX 400 to 630

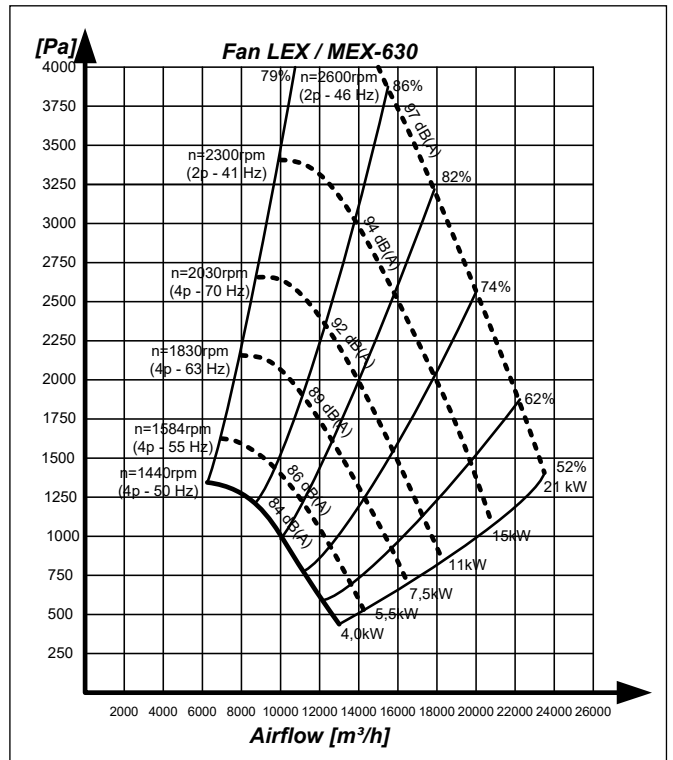
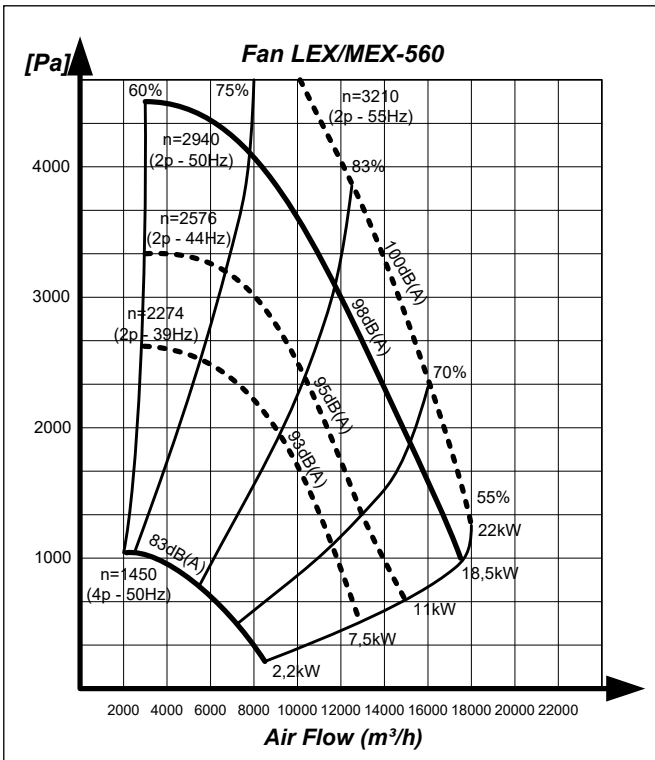
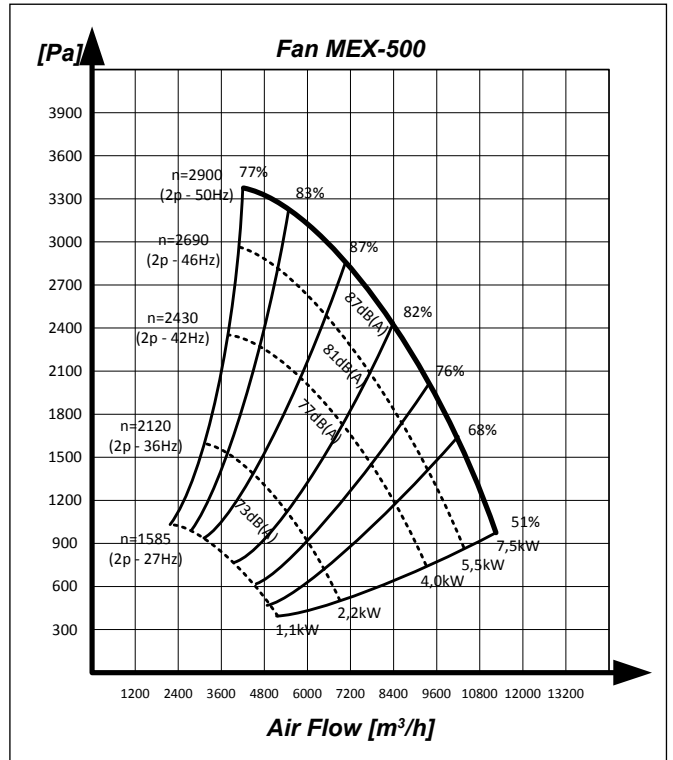
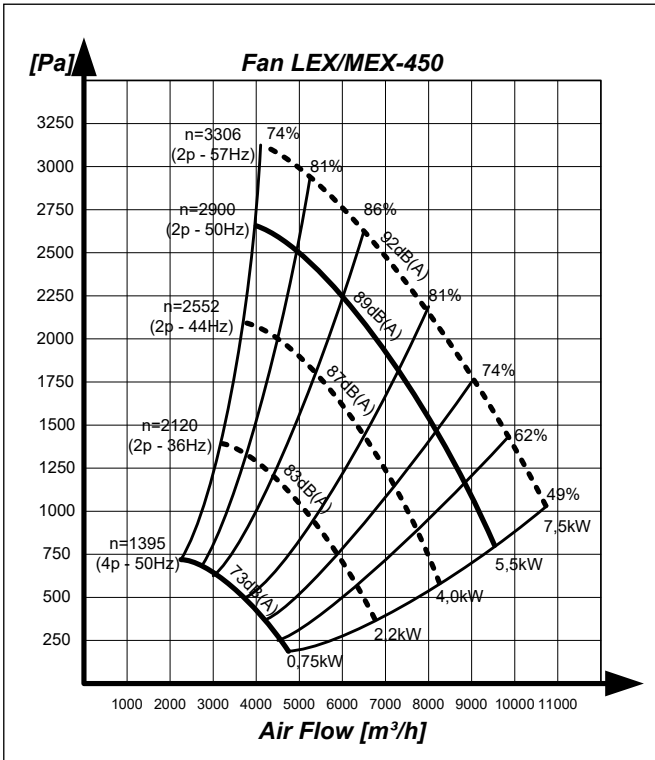



## ASX extraction arm with external articulated arm and gas spring

ATEX  
Compliant

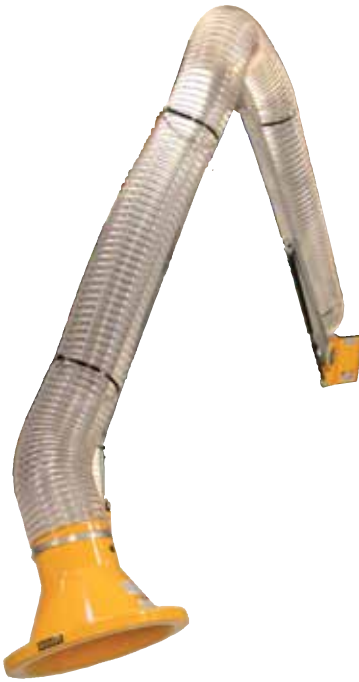

Extraction arm for use in explosive atmosphere (ATEX).  
Double grounding (Resistance  $R < 108\Omega$ ) ensures that the arm will not function as ignition. This allows the arm to be used in areas with gas or dust classified as explosive area (ATEX).  
The ASX arms are based on the construction of our ASA arm.

Art. No.	Description
ASX-01	ASX arm 2,0m ø80 mm, complete
ASX-05	ASX arm 2,0m ø80 mm complete w/ damper
ASX-11	ASX arm 3,0m ø80 mm, complete
ASX-15	ASX arm 3,0m ø80 mm, complete w/ damper
ASX-21	ASX arm 4,0m ø80 mm, complete
ASX-25	ASX arm 4,0m ø80 mm complete w/ damper

ASX-02	ASX arm 2,0m ø100 mm, complete
ASX-06	ASX arm 2,0m ø100 mm complete w/ damper
ASX-12	ASX arm 3,0m ø100 mm, complete
ASX-16	ASX arm 3,0m ø100 mm complete w/ damper
ASX-22	ASX arm 4,0m ø100 mm complete
ASX-26	ASX arm 4,0m ø100 mm complete w/ damper

ASX-03	ASX arm 2,0m ø125 mm, complete
ASX-07	ASX arm 2,0m ø125 mm, complete w/ damper
ASX-13	ASX arm 3,0 m ø125 mm, complete
ASX-17	ASX arm 3,0 m ø125 mm, complete w/ damper
ASX-23	ASX arm 4,0 m ø125 mm, complete
ASX-27	ASX arm 4,0 m ø125 mm, complete w/ damper

ASX-04	ASX arm 2,0m ø160 mm, complete
ASX-08	ASX arm 2,0m ø160 mm, complete w/ damper
ASX-14	ASX arm 3,0m ø160 mm, complete
ASX-18	ASX arm 3,0m ø160 mm, complete w/ damper
ASX-24	ASX arm 4,0m ø160 mm, complete
ASX-28	ASX arm 4,0m ø160 mm, complete w/ damper

ASX-31	ASX arm 2,0m, ø200 mm, complete
ASX-32	ASX arm 2,0m ø200 mm, complete w/ damper
ASX-33	ASX arm 3,0m ø200 mm, complete
ASX-34	ASX arm 3,0m ø200 mm, complete w/ damper
ASX-35	ASX arm 4,0m ø200 mm, complete
ASX-36	ASX arm 4,0m ø200 mm, complete w/ damper

## ASX stainless extraction arm with external articulated arm and gas spring



Stainless Extraction arm for use in explosive atmosphere (ATEX).

Art. No.	Description
ASX-RF-01	ATEX ASX arm 2 m. ø80 stainless
ASX-RF-02	ATEX ASX arm 2 m. ø100 stainless
ASX-RF-03	ATEX ASX arm 2 m. ø125 stainless
ASX-RF-04	ATEX ASX arm 2 m. ø160 stainless
ASX-RF-012	ATEX ASX arm 3 m. ø100 stainless
ASX-RF-013	ATEX ASX arm 3 m. ø125 stainless
ASX-RF-014	ATEX ASX arm 3 m. ø160 stainless
ASX-RF-31	ATEX ASX arm 2 m. ø200 stainless
ASX-RF-33	ATEX ASX arm 3 m. ø200 stainless

## GeoFilter GFX – ATEX filter for zone 20, 21 and 22



Art. No.	Description	Filter areal	Max m <sup>3</sup> /h
16-400	GeoFilter GFX-3-1	30 m <sup>2</sup>	1.800
16-401	GeoFilter GFX-6-2	60 m <sup>2</sup>	3.600
16-402	GeoFilter GFX-9-3	90 m <sup>2</sup>	5.400
16-403	GeoFilter GFX-12-4	120 m <sup>2</sup>	7.200

Geovent GFX filter is used for ATEX processes with explosive dust, making it suitable for dust applications such as aluminum dust, magnesium, flour and more in zone 20, 21 and 22. The filter is 99,9% efficient at 0,3 µm, and is cleaned automatically by using shot valves with compressed air.

The filter is galvanized and is supplied with a 25 l collection bucket.

A GFX filter is supplied complete with ATEX control, explosion membrane, spark proof filter cartridges, ATEX shot valves and full ATEX documentation. KST and Pmax values stated at order.

Compressed air	Air consumption	Power supply	Temperature	Typical pressure drop	Sound level	Prtection class
3 - 6 bar clean and dry air*	3,0 liter/min per valve	24V DC or 230 V AC	-12°C - +65°C	1.000-1.500 Pa	<68 dB(A)	Class C

\*Depending on the processes

## HVUX – High vacuum units for ATEX-applications



GEOVENT high vacuum units (HVU and HVU Lite), are available in ATEX versions for use with dust applications. HVUX and HVUX Lite are designed for a dust filled atmosphere classified as zone 21 or 22.

HVUX og HVUX Lite are tailored to suit your needs. They are available with for example ATEX side channel blower, explosion membrane, police filter (extra protection in case of leak in the primary filter) and customized control with several alarm options.

## Explosion retention valve



Pressure tested to 2.2 bar and approved according to 2014/34/EU (kst. 300 bar/ms). Can be added to new and existing installations. If an explosion occurs, the flap closes automatically, due to the damper plate weight. Strong steel construction and painted in RAL 5010 (blue). Other RAL colors available upon request.

Art. No.	Description
16-596	Explosion retention valve ø100 mm ST1
16-597	Explosion retention valve ø100 mm ST2
16-598	Explosion retention valve ø125 mm ST1
16-599	Explosion retention valve ø125 mm ST2
16-601	Explosion retention valve ø200 mm ST1
16-602	Explosion retention valve ø 250 mm ST1
16-603	Explosion retention valve ø300 mm ST1
16-604	Explosion retention valve ø350 mm ST1
16-605	Explosion retention valve ø400 mm ST1
16-606	Explosion retention valve ø450 mm ST1
16-607	Explosion retention valve ø500 mm ST1
16-608	Explosion retention valve ø550 mm ST1
16-609	Explosion retention valve ø600 mm ST1

# WORKPLACE DESIGN



GEOVENT deliver customized welding booths, welding walls/shielding and noise damping for welding stations. It can be simple walls of different types of sheets provided with curtains or more advanced walls with roof and a center column for the transfer of gases, electricity and ventilation.

If noise reduction is required, the cabinets are delivered in a modular, sandwich-built panel system with smooth or perforated outer- and inner panels. (Fiber cloths, protects the rock wool from getting out.) With rock wool between.

The panels are available in several sizes and designs and they are used for encapsulation of noisy machines, firewalls, paint booths, office rooms and for welding and grinding booths in industry or technical schools.

Contact Geovent for information on prices and options.



Complete construction of technical school with welding cabins and welding station.





Examples of welding booth from GEOVENT. Custom center column with various outlets for gas, power and extraction.

Sound/ welding cabins are used for many purposes. The primary is to define the work area, while co-workers are protected from light and noise. The cabins are always custom made and designed for the specific job.

We have extensive experience from previous projects, so use us as a competent partner for your next project.



## Welding booths



### Art. No. Description

Panel Outside/Inside	
01-303	Geo-Dan 30 Perf/Perf, 50 mm, pr. m <sup>2</sup>
01-304	Geo-Dan 60 Perf/Perf, 100 mm, pr. m <sup>2</sup>
01-305	Geo-Dan 30 PO/PO, 50 mm, pr. m <sup>2</sup>
01-306	Geo-Dan 60 PO/PO, 100 mm, pr. m <sup>2</sup>
01-307	Geo-Dan 30 PO/Perf, 50 mm, pr. m <sup>2</sup>
01-308	Geo-Dan 60 PO/Perf, 100 mm, pr. m <sup>2</sup>

### U-rail for panel assembly

01-309	U-rail, PO 50 mm, per meter
01-310	U-rail, PO 100 mm, per meter

Use one U-rail all the way around each wall (standard sizes)

## Panels for welding booths and noise damping

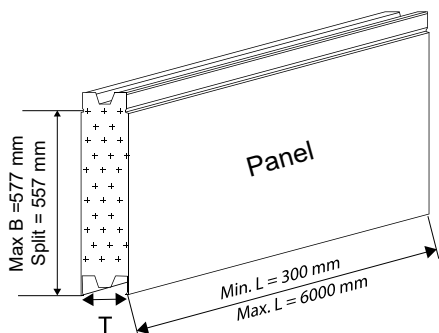

Geo-Dan sandwich built elements with 0,6 mm galvanised and powder coated steel sheet metal on both sides. The panels have a mineral wool core.

Thicknesses: 50 and 100 mm with smooth powder coated (PO) or perforated, powder coated sheet metal. (Perf).

Geo-Dan are assembled with snap lock and sealing.

The panels are approved for use as fire wall according to Danish standards.

Silver (RAL 9006) by default but available in other RAL colours.



	Thickness	Heat loss	Width	Weight
Geo-Dan 30	50 mm	0,67 W/m <sup>2</sup>	557 mm	19,0 kg/m <sup>2</sup>
Geo-Dan 60	100 mm	0,34 W/m <sup>2</sup>	557 mm	26,1 kg/m <sup>2</sup>

Noise reduction in dB(A) ± 3									
Panels outside/inside	Hz	63	125	250	500	1000	2000	4000	
Geo-Dan 30 PO/PO	dB(A)	21	25	29	32	36	38	42	
Geo-Dan 60 PO/PO	dB(A)	28	30	32	36	39	44	49	
Geo-Dan 30 PO/Perf	dB(A)	17	20	20	24	25	27	32	
Geo-Dan 60 PO/Perf	dB(A)	23	22	22	29	29	32	39	

## Accessories for welding booths

- Extra insulation to avoid thermal bridges.
- U-rails for combining several panels.
- V-rails inside and outside for extra finish.
- Windows and doors.
- Curtain and rails and more.

Please enquire for more information on drawings, prices and special requests.

## Welding curtain (translucent)



By default the curtain is green. Other colours on request. Standard sizes shown, special sizes on request. Soft but tough quality.	
Art. No.	Description
01-320	Welding curtain 180 x 130 cm
01-322	Welding curtain 180 x 180 cm
01-328	Velcro connection 180 cm
01-325	Other sizes – per m <sup>2</sup> . Min. 10 m <sup>2</sup> per curtain. Add 10% folds horizontally

## Brackets and suspension



Art. No.	Description
01-340	C-rail 42x50 mm Lengths of 7m
07-828	Connector w. grub screws for 2 lengths of C-rail 42x50 mm
01-342	Arch 600 mm 42x50 mm profile
01-343	Curtain roller with hook for C-profile 42x50 mm
01-345	Rail stop
01-350A	Wall bracket for 42x50 C-profile
01-344	Ceiling bracket for 42x50 C-profile
07-817	Ceiling bracket w. adjustment tread. Bolt M12x60 mm. Use with 01-351
01-351	Wall bracket for wall mounting



Mounting on pipes	
01-335	S-hook, galvanized 4,2x45 mm
01-335A	Curtain hook (drop shaped). Ø42 mm, l=72 mm
01-354	Welding curtain stand 200 x 180 cm. Curtain included
01-354A	Welding curtain stand 200 x 360 cm. Curtain included



## Welding table - down draft

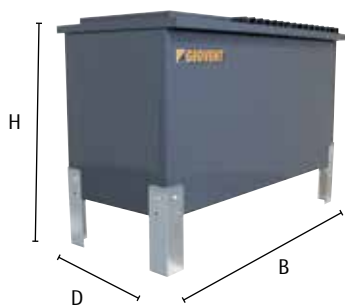

Art. No.	Description
02-001	Welding table - 600x600x800 mm (WxDxH) Air flow needed: ca. 1.500m <sup>3</sup> /h - connector: ø200 mm
02-002	Welding table - 900x600x800 mm (WxDxH) Air flow needed: ca. 2.000m <sup>3</sup> /h - connector: ø200 mm
02-003	Welding table - 1.200x600x800 mm (WxDxH) Air flow needed: ca. 2.500m <sup>3</sup> /h - connector: ø250 mm
02-005	Welding table - 1.800x1.000x800 mm (WxDxH) Air flow needed: ca. 6.000m <sup>3</sup> /h - connector: ø400 mm
02-006	Welding table - 2.500x800x800 mm (WxDxH) Air flow needed: ca. 5.000m <sup>3</sup> /h - connector: 2xø315 mm (in both ends of the table)

## Backdraft extraction



Art. No.	Description
02-030	Backdraft extraction - 900x185x750 mm (WxDxH) Air flow needed: app. 1.000 - 1.500 m <sup>3</sup> /h - connector: ø200 mm with collection drawer
02-037	Corner console for Backdraft extraction



## Smoking cabin



Smoking cabin specially designed for use offshore and on board ships. Withstands vibrations. With EC-fans and push/pull-system. The air is filtered 99,9% through EU5, activated carbon and Hepa filters, and is recirculated. Light and fan activated using sensor. Capacity: 350m<sup>3</sup>/h, 1x230V 50Hz, Consumption: 175W/1,3A, 45dB(A), HxWxD: 2000x1200x1000mm

Art. No.	Description
02-100	Smoking cabin
15-499	Pre-filter for smoking cabin
15-500	Hepa filter 610-305
15-501	Activated carbon filter H13 1500

## Spray booth



Spray booth, w=1400 mm

Spray booth for smaller item. With light, Andrae-filter, wheels and drip tray. Galvanized. Recommended airflow: 2.000 m<sup>3</sup>/h, connector ø250 mm. 230V. H: 2035 mm W: 1000 mm D:1000 mm

Art. No.	Description
01-800	Spray booth, W=1000 mm
01-801	Spray booth, W=1400 mm
01-802	Spray booth, W=1800 mm



Andraefilter for spray booth

# WELDING TABLE



Customized table

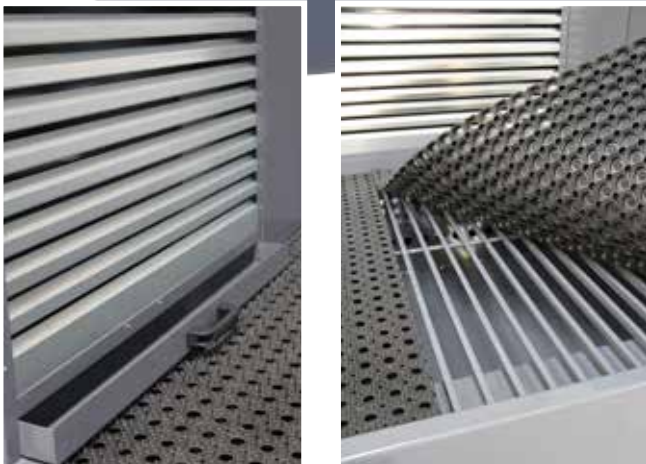

Geovent solves many customer specified requests. In the pictures on the left, you see a grinding table with rubber mats. Table size above is 2.5 x 1.25m with vacuum in table/ rear a particle trap.

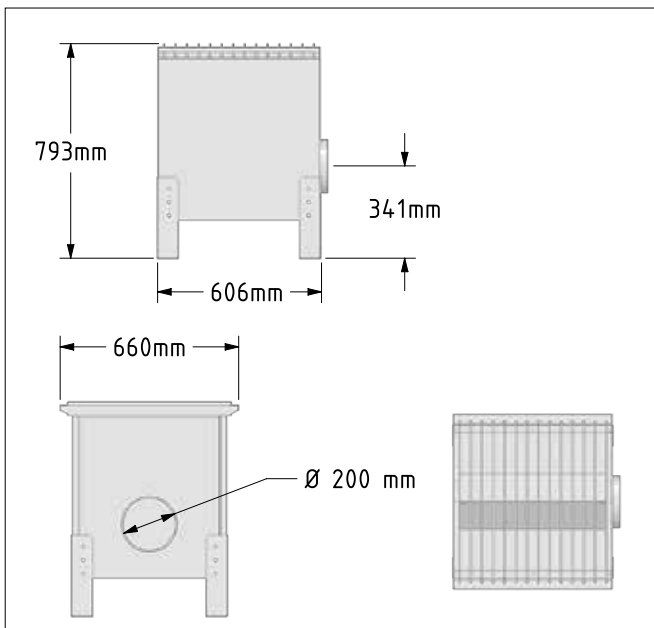

02-001 Welding table



Above, standard table. Lamels are easy to move.

# GRTU ROOF TOP UNIT



GRTU Roof top ventilation units with heat recovery are designed for comfort ventilation in repair shops, warehouses and production facilities.

GRTU uses energy efficient EC fans with B-wheels. The fans comply with the latest requirements. Both fans are 100% stepless so you can achieve the desired airflow for your application.

GRTU is a flexible and economically attractive solution as the roof mounting eliminates the need for ductwork.



The GRTU roof top unit is fitted with a high quality control system and can be operated by either hand terminal or computer (LAN).

# GRTU ROOF TOP UNIT



Dimensions GRTU

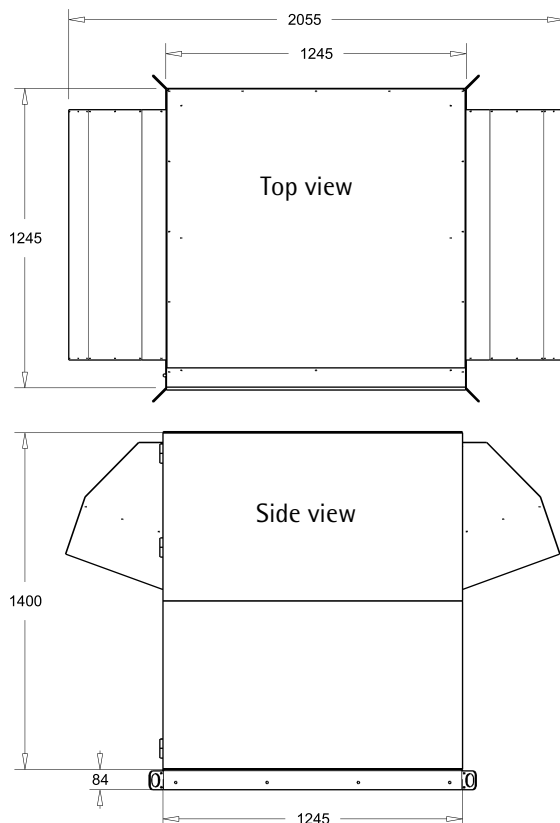

## Flexibility without compromising on quality

The Geovent GRTU Roof Top Unit ensures steady and stable operation, as it is designed using only selected quality components.

The rotary heat exchanger has a large area for optimum performance.

The entire construction is galvanized and sealed in all joints.

The GRTU is modular and with hatched doors for easy inspection and service.

The mounting frame makes it easy to install the unit on both a flat and a sloped roof.

The GRTU 3800+ can also be mounted indoors if required. (Must be specified when ordering.)

Extraction and air supply is in the bottom of the unit.

Choose between duct solution or diffuser solution. Normally we recommend the duct solution as it gives a better mixing of the air.

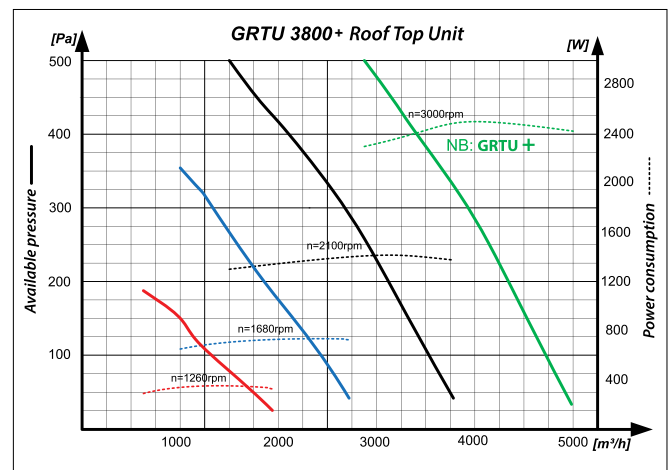

Unit weight 400 kg.

## GRTU roof top unit with heat recovery



Art. No.	Description
02-602A	GRTU 3800+ standard edition. Rotor heat exchanger, 0-4.500 m <sup>3</sup> /h, pressure controlled EC-fans and digital auto-matics with operating panel. Galvanized construction, EU7 panel filters and 50 mm insulation. Up to 84% efficiency on rotor.

## Accessories for GRTU



Art. No.	Description
02-703	Shut-off damper without motor. Used in air intake and outlet and as recirculation damper
02-710	Motor for damper

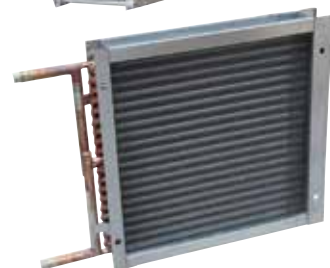

02-711	Heating coil 10kW 70/40 Used where only ventilation is needed. Measures: 600x600 mm. For duct mounting
02-713	Heating coil 25kW 70/40 Used where heating and recirculation is needed. Measures: 600x600 mm. For duct mounting



02-712	2 way valve R210 + motor TR24 SR Suitable for 10kW heating coil
02-714	2 way valve R212 + motor TR24 SR Suitable for 25kW heating coil
02-704	Temperature sensor/Frost protection. Used with heating coil 10 and 25kW.
02-705	Room sensor. Use when heating

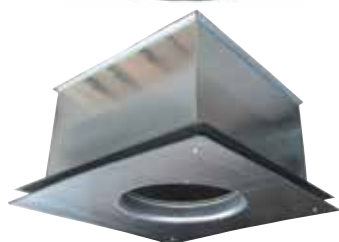

02-715	Diffusor set Reduction piece, flex hose ø500 mm with clamps and diffusor mounted on 800x800 mm rectangular duct
--------	--



02-721	Hand terminal HMI for GRTU Exclusive design with colour display and touch
--------	--

02-761	Extension duct 800x800x500 mm
02-762	Extension duct 800x800x1000 mm
09-017A	Flex hose ø500 mm, per m.



02-717	Cassette filter EU7 Set of 2 pcs.
--------	--------------------------------------



**GeoFlex Exhaust (170°C – briefly 200°C)**

**EPDM / PP plastic coil**



Use: Extraction of exhaust fumes and welding smoke.  
(May be run over to a certain extent)

Art. No.	Description	Weight	Bend
09-075A	GeoFlex Exhaust ø76 – 5 m pcs.	2,7 kg	73 mm
09-075B	GeoFlex Exhaust ø76 – 7,5 m pcs.	4,1 kg	73 mm
09-075C	GeoFlex Exhaust ø76 – 10 m pcs.	5,4 kg	73 mm
09-075D	GeoFlex Exhaust ø76 – 15 m pcs.	8,2 kg	73 mm
09-076A	GeoFlex Exhaust ø102 – 5 m pcs.	3,6 kg	71 mm
09-076B	GeoFlex Exhaust ø102 – 7,5 m pcs.	5,3 kg	71 mm
09-076C	GeoFlex Exhaust ø102 – 10 m pcs.	7,2 kg	71 mm
09-076D	GeoFlex Exhaust ø102 – 15 m pcs.	10,6 kg	71 mm
09-077A	GeoFlex Exhaust ø127 – 5 m pcs.	4,4 kg	89 mm
09-077B	GeoFlex Exhaust ø127 – 7,5 m pcs.	6,5 kg	89 mm
09-077C	GeoFlex Exhaust ø127 – 10 m pcs.	8,8 kg	89 mm
09-077D	GeoFlex Exhaust ø127 – 15 m pcs.	13,0 kg	89 mm
09-078A	GeoFlex Exhaust ø152 – 5 m pcs.	5,2 kg	106 mm
09-078B	GeoFlex Exhaust ø152 – 7,5 m pcs.	7,8 kg	106 mm
09-078C	GeoFlex Exhaust ø152 – 10 m pcs.	10,4 kg	106 mm
09-078D	GeoFlex Exhaust ø152 – 15 m pcs.	15,6 kg	106 mm
09-079A	GeoFlex Exhaust ø200 – 5 m pcs.	6,9 kg	143 mm
09-079B	GeoFlex Exhaust ø200 – 7,5 m pcs.	10,3 kg	143 mm
09-079C	GeoFlex Exhaust ø200 – 10 m pcs.	13,8 kg	143 mm
09-079D	GeoFlex Exhaust ø200 – 15 m pcs.	20,6 kg	143 mm

(May be run over to a certain extent)

**GeoFlex Kevlar HT (-60°C to +260°C – briefly 300°C)**

**Kevlar Silicone w/galv. steel coil**



Use:  
Extraction of hot vapours, exhaust or dust

Art. No.	Description	Weight	Bend
09-190	GeoFlex Kevlar ø83, per meter	0,95 kg/m	34 mm
09-191	GeoFlex Kevlar ø102, per meter	0,86 kg/m	40 mm
09-192	GeoFlex Kevlar ø127, per meter	1,07 kg/m	48 mm
09-193	GeoFlex Kevlar ø152, per meter	0,83 kg/m	55 mm
09-194	GeoFlex Kevlar ø160, per meter	0,89 kg/m	58 mm
09-195	GeoFlex Kevlar ø203, per meter	1,1 kg/m	70 mm
09-196	GeoFlex Kevlar ø254, per meter	1,4 kg/m	86 mm
09-197	GeoFlex Kevlar ø305, per meter	1,67 kg/m	102 mm

(Kevlar-reinforced 300° hose – lengths of 1 to 10 m)

**GeoFlex Exhaust HT-450 (-60°C to +450°C – briefly 500°C)**

**Silicone coated fiber glas w/galv. profile**



Use:  
Extraction of hot vapours, exhaust or dust

Art. No.	Description	Weight	Bend
09-130	GeoFlex Exhaust HT-450 ø102, per meter	1,29 kg/m	51 mm
09-131	GeoFlex Exhaust HT-450 ø127, per meter	1,60 kg/m	61 mm
09-132	GeoFlex Exhaust HT-450 ø152, per meter	1,34 kg/m	38 mm
09-133	GeoFlex Exhaust HT-450 ø160, per meter	1,46 kg/m	40 mm
09-134	GeoFlex Exhaust HT-450 ø203, per meter	1,81 kg/m	48 mm

Available in lengths of 1 to 10 m

**GeoFlex Exhaust HT-650 (-60°C to +600°C - briefly 700°C)**

**Special high temp-weave/stainless coil**



Use:  
Extraction of hot vapours,  
exhaust or dust

Art. No.	Description	Weight	Bend
09-159	GeoFlex Exhaust HT-650 ø102, per meter	2,1 kg/m	53 mm
09-161	GeoFlex Exhaust HT-650 ø127, per meter	2,6 kg/m	63 mm
09-163	GeoFlex Exhaust HT-650 ø152, per meter	2,11 kg/m	73 mm
09-164	GeoFlex Exhaust HT-650 ø160, per meter	2,25 kg/m	77 mm
09-165	GeoFlex Exhaust HT-650 ø203, per meter	2,79 kg/m	93 mm
09-166	GeoFlex Exhaust HT-650 ø250, per meter	3,53 kg/m	115 mm
09-169	GeoFlex Exhaust HT-650 ø315, per meter	4,35 kg/m	139 mm

Available in lengths of 1 to 10 m

**GeoFlex Exhaust HT-1100 (-60°C to +900°C - briefly 1100°C)**

**3 ply special high temp-weave/stainless coil**



Use:  
Extraction of for ex. exhaust from  
locomotives, tanks and more with  
very high temperatures.

Art. No.	Description	Weight	Bend
09-140	GeoFlex Exhaust HT-1100 ø102, per meter	2,8 kg/m	64 mm
09-141	GeoFlex Exhaust HT-1100 ø127, per meter	3,43 kg/m	77 mm
09-142	GeoFlex Exhaust HT-1100 ø152, per meter	3,07 kg/m	89 mm
09-143	GeoFlex Exhaust HT-1100 ø160, per meter	3,27 kg/m	94 mm
09-144	GeoFlex Exhaust HT-1100 ø203, per meter	4,03 kg/m	114 mm

Available in lengths of 1 to 10 m

**GeoFlex Standard (-30°C to +140°C)**

**PVC / ALU**



Use:  
Extraction of air, welding smoke  
and fumes.

Art. No.	Description	Weight	Bend
09-012	GeoFlex Standard ø50, 10 meter pcs	0,146 kg/m	29 mm
09-002	GeoFlex Standard ø82, 10 meter pcs	0,162 kg/m	48 mm
09-003	GeoFlex Standard ø102, 10 meter pcs	0,171 kg/m	59 mm
09-005	GeoFlex Standard ø127, 10 meter pcs	0,212 kg/m	74 mm
09-001	GeoFlex Standard ø152, 10 meter pcs	0,326 kg/m	88 mm
09-004	GeoFlex Standard ø160, 10 meter pcs	0,357 kg/m	93 mm
09-000	GeoFlex Standard ø203, 10 meter pcs	0,461 kg/m	118 mm
09-019	GeoFlex Standard ø254, 10 meter pcs	0,618 kg/m	147 mm

**GeoFlex Weld (-10°C to +60°C - briefly 110°C)**

**PVC / Polyester weave steel coil**



Use:  
Extraction of wood dust, metal dust,  
oil and petrol fumes.  
Suitable for wood- food- and  
pharmaceutical industry.

Art. No.	Description	Weight	Bend
09-306	GeoFlex Weld ø80	0,19 kg/m	43 mm
09-307	GeoFlex Weld ø102	0,24 kg/m	54 mm
09-310	GeoFlex Weld ø127	0,32 kg/m	67 mm
09-312	GeoFlex Weld ø152	0,37 kg/m	79 mm
09-313	GeoFlex Weld ø165	0,46 kg/m	86 mm
09-314	GeoFlex Weld ø203	0,60 kg/m	105 mm
09-315	GeoFlex Weld ø250	0,77 kg/m	129 mm

Available in lengths of 2, 3, 4, 5 or 10 m. Price per meter.

**GeoFlex PUR (-40°C to +90°C - briefly 125°C)**

**PUR, antistatic**



Use: Extraction of wood dust, flour dust, oil and petrol fumes. Suitable for wood- food- and pharmaceutical industry.

Art. No.	Description	Weight	Bend
09-403	GeoFlex PUR ø50	0,37 kg/m	33 mm
09-407	GeoFlex PUR ø80	0,57 kg/m	48 mm
09-408	GeoFlex PUR ø100	0,67 kg/m	58 mm
09-410	GeoFlex PUR ø125	0,83 kg/m	71 mm
09-412	GeoFlex PUR ø150	0,99 kg/m	83 mm
09-412A	GeoFlex PUR ø160	1,05 kg/m	88 mm
09-414	GeoFlex PUR ø200	1,33 kg/m	108 mm
09-415	GeoFlex PUR ø250	1,64 kg/m	133 mm

Available in lengths of 5, 10 or 15 m. Price per meter.

**GeoFlex High (-40°C to +60°C) Black, antistatic**

**EVA**



Use: Extraction of exhaust, dust, air and welding fumes.

Art. No.	Description	Weight	Bend
09-007	GeoFlex High ø32 - up to 20m	0,27 kg/m	80 mm
09-008	GeoFlex High ø38 - up to 20m	0,32 kg/m	100 mm
09-009	GeoFlex High ø51 - up to 20m	0,44 kg/m	150 mm
09-082	GeoFlex High ø64 - up to 15m	0,54 kg/m	250 mm

Lengths: Per meter, up to 20 m. Price per meter.

**GeoFlex High (-40°C to +60°C) Yellow, not antistatic**

**EVA**



Art. No.	Description	Weight	Bend
09-020	GeoFlex High ø45 - up to 20m	0,38 kg/m	125 mm
09-010	GeoFlex High ø76 - up to 10m	0,65 kg/m	300 mm

Lengths: Per meter, up to 20 m. Price per meter.

**GeoFlex Exhaust 220 up to 220°C**

**TPE w/steel coil**



Use: Extraction of exhaust fumes and welding smoke. It is not crushproof.

Art. No.	Description	Weight	Bend
09-095A	GeoFlex Exhaust-220 ø76 mm x 5 meters pcs	2,4 kg.	55 mm
09-095B	GeoFlex Exhaust-220 ø76 mm x 7,5 meters pcs	3,6 kg.	55 mm
09-095C	GeoFlex Exhaust-220 ø76 mm x 10 meters pcs	4,8 kg.	55 mm
09-095D	GeoFlex Exhaust-220 ø76 mm x 15 meters pcs	7,2 kg.	55 mm
09-096A	GeoFlex Exhaust-220 ø102 mm x 5 meters pcs	3,3 kg.	45 mm
09-096B	GeoFlex Exhaust-220 ø102 mm x 7,5 meters pcs	4,95 kg.	45 mm
09-096C	GeoFlex Exhaust-220 ø102 mm x 10 meters pcs	6,6 kg.	45 mm
09-096D	GeoFlex Exhaust-220 ø102 mm x 15 meters pcs	9,9 kg.	45 mm
09-097A	GeoFlex Exhaust-220 ø127 mm x 5 meters pcs	4,5 kg.	65 mm
09-097B	GeoFlex Exhaust-220 ø127 mm x 7,5 meters pcs	6,75 kg.	65 mm
09-097C	GeoFlex Exhaust-220 ø127 mm x 10 meters pcs	9 kg.	65 mm
09-097D	GeoFlex Exhaust-220 ø127 mm x 15 meters pcs	13,5 kg.	65 mm
09-098A	GeoFlex Exhaust-220 ø152 mm x 5 meters pcs	5,75 kg.	85 mm
09-098B	GeoFlex Exhaust-220 ø152 mm x 7,5 meters pcs	8,63 kg.	85 mm
09-098C	GeoFlex Exhaust-220 ø152 mm x 10 meters pcs	11,5 kg.	85 mm
09-098D	GeoFlex Exhaust-220 ø152 mm x 15 meters pcs	17,25 kg.	85 mm
09-099A	GeoFlex Exhaust-220 ø200 mm x 5 meters pcs	7,6 kg.	125 mm
09-099B	GeoFlex Exhaust-220 ø200 mm x 7,5 meters pcs	11,4 kg.	125 mm
09-099C	GeoFlex Exhaust-220 ø200 mm x 10 meters pcs	15,2 kg.	125 mm
09-099D	GeoFlex Exhaust-220 ø200 mm x 15 meters pcs	22,8 kg.	125 mm

As standard it is delivered in black / black, but by request it can be delivered in black / yellow, black / blue, black / green or black / red, minimum buy is 30m. Expect a delivery time of 4 weeks.

## Connection piece for connecting 2 hoses



Art. No.	Description
57-002	Connecting piece ø80 mm
57-003	Connecting piece ø100 mm
57-001	Connecting piece ø125 mm
57-013	Connecting piece ø150 mm
57-004	Connecting piece ø160 mm
57-005	Connecting piece ø200 mm

## Hose clamps



Art. No.	Description
09-033	Hose clamp ø70 - 90 mm
09-034	Hose clamp ø90 - 110 mm
09-035	Hose clamp ø120 - 140 mm
09-036	Hose clamp ø150 - 170 mm
09-037	Hose clamp ø190 - 210 mm
01-499	Rubber band ø125 - 160 black
01-498	Rubber band ø200 black

## Quick coupling for medium pressure

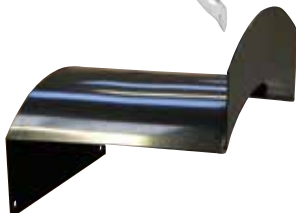

Art. No.	Description
05-005	Quick coupling 80V for wall mounting
05-008	Quick coupling 80L hanging
05-006	Quick coupling 100V for wall mounting
05-009	Quick coupling 100L hanging
05-011	Hose piece for quick coupling 80V/L
05-014	Hose piece for quick coupling 100V/L
05-013	Hose piece 80/100 for quick coupling 80V/L
06-400	Quick coupling 80 VL with end cover
06-401	Quick coupling 100 VL with end cover
06-402	Quick coupling 125 VL with end cover
06-403	Quick coupling 150 VL with end cover
06-404	Quick coupling 160 VL with end cover
06-405	Quick coupling 200 VL with end cover
06-409	Switch for Quick coupling
06-410	Hose piece 80 VL
06-411	Hose piece 100 VL
06-412	Hose piece 125 VL
06-413	Hose piece 150 VL
06-414	Hose piece 160 VL
06-415	Hose piece 200 VL
91-285	Snap lock ø80 VL
91-286	Snap lock ø100 VL
91-287	Snap lock ø125 VL
91-288	Snap lock ø150 VL
91-289	Snap lock ø160 VL
91-290	Snap lock ø200 VL
07-016A	Hose holder ø100/150 mm - wall mounted

## Duct and accessories



Spiro duct



Support Bracket



T-piece



90° bend



45° bend



30° bend



RCL reduction

### Duct

Art. No.	Description
50-002	Spiro duct ø80
50-003	Spiro duct ø100
50-001	Spiro duct ø125
50-004	Spiro duct ø160
50-005	Spiro duct ø200
50-006	Spiro duct ø250
50-007	Spiro duct ø315
50-008	Spiro duct ø400

### Support bracket

Art. No.	Description
07-002	Support bracket FA-80
07-003	Support bracket FA-100
07-001	Support bracket FA-125
07-004	Support bracket FA-160
07-005	Support bracket FA-200
07-006	Support bracket FA-250
07-007	Support bracket FA-315
07-008	Support bracket FA-400

### T-piece

Art. No.	Description
54-022	T-piece 80-80-80
54-032	T-piece 100-80-100
54-033	T-piece 100-100-100
54-012	T-piece 125-80-125
54-013	T-piece 125-100-125
54-011	T-piece 125-125-125
54-042	T-piece 160-80-160
54-043	T-piece 160-100-160
54-015	T-piece 160-125-160
54-044	T-piece 160-160-160
54-052	T-piece 200-80-200
54-053	T-piece 200-100-200
54-016	T-piece 200-125-200
54-054	T-piece 200-160-200
54-055	T-piece 200-200-200
54-062	T-piece 250-80-250
54-063	T-piece 250-100-250
54-017	T-piece 250-125-250
54-064	T-piece 250-160-250
54-065	T-piece 250-200-250

### T-piece

Art. No.	Description
54-066	T-piece 250-250-250
54-074	T-piece 315-160-315
54-075	T-piece 315-200-315
54-076	T-piece 315-250-315
54-077	T-piece 315-315-315
54-088	T-piece 400-400-400

### Bends

Art. No.	Description
51-002	90° bend ø80
51-003	90° bend ø100
51-001	90° bend ø125
51-004	90° bend ø160
51-005	90° bend ø200
51-006	90° bend ø250
51-007	90° bend ø315
51-008	90° bend ø400

52-002	45° bend Ø80
52-003	45° bend Ø100
52-001	45° bend Ø125
52-004	45° bend Ø160
52-005	45° bend Ø200
52-006	45° bend Ø250
52-007	45° bend Ø315
52-008	45° bend Ø400

53-002	30° bend ø80
53-003	30° bend ø100
53-001	30° bend ø125
53-004	30° bend ø160
53-005	30° bend ø200
53-006	30° bend ø250
53-007	30° bend ø315
53-008	30° bend ø400

### Reductions

Art. No.	Description
55-032	Reduction 100-80
55-012	Reduction 125-80
55-013	Reduction 125-100
55-042	Reduction 160-80
55-043	Reduction 160-100



## Duct and accessories



Saddle



Conn. nipple



Conn. muff



End cap NP



Adjustment damper



Shut-off damper



Outlet hoods

### Reductions

Art. No.	Description
55-041	Reduction 160-125
55-052	Reduction 200-80
55-053	Reduction 200-100
55-051	Reduction 200-125
55-054	Reduction 200-160
55-062	Reduction 250-80
55-063	Reduction 250-100
55-061	Reduction 250-125
55-064	Reduction 250-160
55-065	Reduction 250-200
55-071	Reduction 315-125
55-074	Reduction 315-160
55-075	Reduction 315-200
55-076	Reduction 315-250
55-085	Reduction 400-200
55-086	Reduction 400-250
55-087	Reduction 400-315

### Saddle

Art. No.	Description
62-022	Saddle 80-80
62-032	Saddle 100-80
62-033	Saddle 100-100
62-012	Saddle 125-80
62-013	Saddle 125-100
62-011	Saddle 125-125
62-042	Saddle 160-80
62-043	Saddle 160-100
62-041	Saddle 160-125
62-044	Saddle 160-160
62-052	Saddle 200-80
62-053	Saddle 200-100
62-051	Saddle 200-125
62-054	Saddle 200-160
62-055	Saddle 200-200
62-062	Saddle 250-80
62-063	Saddle 250-100
62-061	Saddle 250-125
62-064	Saddle 250-160
62-065	Saddle 250-200
62-066	Saddle 250-250
62-073	Saddle 315-100

### Saddle

Art. No.	Description
62-071	Saddle 315-125
62-074	Saddle 315-160
62-075	Saddle 315-200
62-076	Saddle 315-250
62-077	Saddle 315-315
62-081	Saddle 400-125
62-084	Saddle 400-160
62-085	Saddle 400-200
62-086	Saddle 400-250
62-087	Saddle 400-315

### Nipples and muffs

Art. No.	Description
57-002	Connecting nipple 80
57-003	Connecting nipple 100
57-001	Connecting nipple 125
57-004	Connecting nipple 160
57-005	Connecting nipple 200
57-006	Connecting nipple 250
57-007	Connecting nipple 315
57-008	Connecting nipple 400

58-002	Connecting muff 80
58-003	Connecting muff 100
58-001	Connecting muff 125
58-004	Connecting muff 160
58-005	Connecting muff 200
58-006	Connecting muff 250
58-007	Connecting muff 315
58-008	Connecting muff 400

59-002	End cap nipple 80
59-003	End cap nipple 100
59-001	End cap nipple 125
59-004	End cap nipple 160
59-005	End cap nipple 200
59-006	End cap nipple 250
59-007	End cap nipple 315
59-008	End cap nipple 400

60-002	End cap muff 80
60-003	End cap muff 100
60-001	End cap muff 125
60-004	End cap muff 160

## Duct and accessories



End cap MF



Sliding damper



Roof transition



Silencer



Louvred grille

### Nipples and muffs

Art. No.	Description
60-005	End cap muff 200
60-006	End cap muff 250
60-007	End cap muff 315
60-008	End cap muff 400

### Damper

Art. No.	Description
61-002	Adjustment damper 80
61-003	Adjustment damper 100
61-001	Adjustment damper 125
61-004	Adjustment damper 160
61-005	Adjustment damper 200
61-006	Adjustment damper 250
61-007	Adjustment damper 315
61-008	Adjustment damper 400

61-022	Shut-off damper 80 tight
61-023	Shut-off damper 100 tight
61-021	Shut-off damper 125 tight
61-024	Shut-off damper 160 tight
61-025	Shut-off damper 200 tight
61-026	Shut-off damper 250 tight
61-027	Shut-off damper 315 tight
61-028	Shut-off damper 400 tight

61-102	Sliding damper 80
61-103	Sliding damper 100
61-101	Sliding damper 125
61-086	Sliding damper 160
61-087	Sliding damper 200
61-106	Sliding damper 250
61-107	Sliding damper 315

### Roof transitions

Art. No.	Description
08-070	Roof transition 100-0°
08-071	Roof transition 125-0°
08-072	Roof transition 160-0°
08-073	Roof transition 200-0°
08-074	Roof transition 250-0°
08-075	Roof transition 315-0°
08-076	Roof transition 400-0°

### Roof transitions

Art. No.	Description
08-077	Roof transition 100-1-20°
08-078	Roof transition 125-1-20°
08-079	Roof transition 160-1-20°
08-080	Roof transition 200-1-20°
08-081	Roof transition 250-1-20°
08-082	Roof transition 315-1-20°
08-083	Roof transition 400-1-20°

### Outlet hoods

Art. No.	Description
08-029	Deflector Cap 100
08-027	Deflector Cap 125
08-030	Deflector Cap 160
08-031	Deflector Cap 200
08-032	Deflector Cap 250
08-033	Deflector Cap 315
08-034	Deflector Cap 400

### Silencer

Art. No.	Description
63-013	Silencer $\varnothing$ 100 L=600
63-022	Silencer $\varnothing$ 125 L=600
63-024	Silencer $\varnothing$ 160 L=900
63-025	Silencer $\varnothing$ 200 L=900
63-026	Silencer $\varnothing$ 250 L=900
63-027	Silencer $\varnothing$ 315 L=900
63-028	Silencer $\varnothing$ 400 L=900

### Louvred grille

Art. No.	Description
64-000	Louvred grille $\varnothing$ 100 mm
64-001	Louvred grille $\varnothing$ 125 mm
64-002	Louvred grille $\varnothing$ 160 mm
64-003	Louvred grille $\varnothing$ 200 mm
64-004	Louvred grille $\varnothing$ 250 mm
64-005	Louvred grille $\varnothing$ 315 mm
64-006	Louvred grille $\varnothing$ 400 mm

## Sales and delivery terms

### 1. Application

These conditions of sale and delivery shall apply to all supplies from GEOVENT A/S, and thus all agreements and trade customs, which are contrary to the conditions, including such conditions as prepared and submitted by the purchaser, are set aside, unless otherwise appears from the order confirmation, as submitted by us. The conditions are also regarded as accepted for all future business without explicit mentioning it.

### 2. Conclusion of Agreements

GEOVENT A/S is committed to the statements made by us, no matter how these are described, when we have submitted an order confirmation or effected delivery, at the earliest. The purchasers are responsible for the correctness of the information and specifications of orders, including specifications on drawings and similar documents.

### 3. Power of attorney

No individual person/company, who is agent, representative or broker is empowered to commit GEOVENT A/S without prior written agreement.

### 4. Prices

All prices according to the price lists, prepared by us, are current prices, excluding VAT, other public duties and transport packaging. We reserve the right to change price lists and catalogues at any time. In case price increases of more than 5% occur in manufacturing costs and delivery costs as well as in suppliers' prices, after the conclusion of the agreement but before delivery, we are entitled to adjust the price regarding such substantiated cost increases. Moreover, the price is based on the current exchange rates at the time of the conclusion of the agreement. Changes of the exchange rate of more than 5% entitle us to adjust the price accordingly. GEOVENT A/S reserves the right to charge a handling fee of DKK 100.00 for orders below DKK 500.00.

### 5. Terms of delivery

Deliveries are made EXW, DK-Løgstrup, in compliance with Incoterms 1990, which means that - when the product is completely finished and ready for delivery, - the purchaser bears the risk and defrays all costs in connection with the delivery, including the transport costs. In due time, the purchaser is liable to inform GEOVENT A/S of the transport method, which he intends to make use of. Otherwise, GEOVENT A/S is entitled to select transport method and transport route. In case of delayed delivery, GEOVENT A/S is liable immediately to inform the purchaser thereof, and the purchaser is entitled to revoke the Agreement and claim compensation, if the delay is of the essence. A delay of the essence does not exist until at least 30 days after agreed time of delivery. However, the purchaser may not assert the before mentioned rights, if the delay is caused by defaults on the part of the purchaser or on the part of a sub-supplier. In all cases, the purchaser is not entitled to claim compensation for any indirect loss, including compensation for loss of use and loss of profits, and the purchaser cannot assert any additional rights, either. In case the purchaser does not accept delivery at the time of delivery, including that he fails to perform his collection obligations, then GEOVENT A/S is entitled to revoke the Agreement and claim compensation. Furthermore, GEOVENT A/S is entitled to sell or stock the products for the purchaser's account. When storing the products, they are stored at the purchaser's risk. The return of products and packaging may only take place in accordance with prior, written agreement, and in such case, the return will be for the purchaser's account. A return fee of 20% will be charged. Pallets, boxes or other packaging, which is debited separately, will not be credited.

### 6. Terms of payment

Payment must be made net cash on receipt of the product, where nothing else has been agreed to. For late payments, an interest rate of 1.5% will be calculated per month or fraction of a month, calculated from date of payment, and until payment is made. The purchaser is not entitled to use the purchase price - or part hereof - for effecting a set-off, just like the purchaser's complaint in accordance with article 9 does not entitle the purchaser to retain the purchase price. Products are sold conditionally, which entitles GEOVENT A/S to take repossession of the products sold, in case the purchaser, - completely or partly, fails to pay. In case the purchaser violates several of the stated obligations, including his obligation in compliance with article 5, then GEOVENT A/S is entitled to revoke the agreement, sell the products to third party for the purchaser's account and/or claim compensation.

### 7. Warranty

The warranty only covers such products, which are proven to be substantially defective or faulty, due to inadequate manufacturing or due to the use of faulty materials, supplied by GEOVENT A/S. The warranty is only effective, if the products are stored safely, and have been used correctly and in a normal manner by the purchaser in accordance with our specifications. GEOVENT A/S cannot be made responsible for any defects or faults, which occur due to inadequate maintenance, incorrect installation, carried out by the purchaser, for changes made without our written acceptance, or for repairs, which the purchaser has made in an imperfect way. If products or parts comprise non-GEOVENT manufacture, then GEOVENT A/S shall be responsible solely to the extent, that GEOVENT's supplier has accepted the warranty, irrespective of the provisions stated in this article (article 7). If the product is essentially defective or faulty, then we are liable to and entitled to - according to our own choice - repair the defect, to implement a replacement supply, to offer a proportional reduction of the price, or to pay compensation. Transport costs, insurance costs, travelling expenses, installation costs and other costs in connection with the repair or with a replacement supply are to be paid by the purchaser. Our liability to pay compensation is limited to the invoice price of the defective product, and under no circumstances can we be made liable to pay compensation for indirect losses, such as compensation for loss of use and loss of profits. The warranty does not cover electric cables, hydraulic cables, pneumatic cables, or cables for extraction, wearing parts or normal wear and tear. The warranty period is one year.

### 8. Force majeure

GEOVENT A/S is not liable to pay compensation for the failure to perform the obligations, if we can substantiate that this is due to events beyond our control, such as strike, lockout, export ban or import ban, embargoes, delayed or incomplete deliveries of materials from sub-suppliers, production stop, lack of energy or transport possibilities or due to other types of force majeure. In such case, we are entitled to prolong the delivery time accordingly or to revoke the Agreement. A hindrance, lasting longer than three months, entitles both parties to cancel the Agreement.

### 9. Duty to give notice of defects and duty of inspection

The purchaser is liable to inspect the products, immediately on receipt, and at the latest within eight days after receipt to give notice of any defect. If the purchaser does not observe these deadlines, then he loses the right to make claims on account of the effect.

### 10. Product liability

GEOVENT A/S is only liable for personal injury or material damage, caused by our products, in case it can be substantiated that the injury or damage was caused by a mistake or negligence of a product, supplied by us, and if it is substantiated that the product is defective, that the injury or damage was caused by this defect, and that there is causal relation between the injury or damage and the defect. Moreover, we are not liable for damage to real or personal property, caused while the product is in the purchaser's possession, and we are not liable for damage to any products, manufactured by the purchaser, and which our products are part of, just like we are not liable for any consequential loss, any time restricted loss of profits, any loss of earnings or for other direct losses. In case GEOVENT A/S is imposed liabilities, which exceed the above mentioned, then the purchaser is liable to indemnify us in this respect. The purchaser is liable to let legal proceedings institute against him at the same court/arbitration as the one dealing with the question about our product liability.

### 11. Product information

The technical specifications and other indicated measurements in catalogues are of guiding character, and GEOVENT A/S accepts no responsibility for errors in this kind of documentation. All information and data, stated in this documentation, including price lists, are only binding to the extent that the Agreement explicitly refers to such specifications.

### 12. Protection of rights

The purchaser does not obtain any right to the industrial rights of GEOVENT A/S via this present agreement, and the purchaser is unauthorised to using any information about the product and/or the actual product in such a way that the rights of GEOVENT A/S are violated. The purchaser is responsible for not violating the rights of any third party via the products, which have been manufactured in compliance with the purchaser's directions.

### 13. Drawings and descriptions

All drawings and technical documents regarding the material or the preparation thereof, which previous to, or after the conclusion of the agreement have been left with the purchaser, belong to GEOVENT A/S and may not be copied, reproduced or handed over to, or in any other way be communicated to any third party, without prior acceptance from GEOVENT A/S. On request, such material must be returned.

### 14. Governing law and arbitration

Any disputes, arising in connection with this Agreement, must be settled in accordance with Danish rules of law. In case any dispute cannot be settled out of court, then proceedings shall be commenced at the venue of GEOVENT A/S.

**Geovent A/S assumes no liability for obvious mistakes or printing or spelling errors in this catalogue.**

Process	Air flow per outlet [m <sup>3</sup> /h]	Hose dimension [mm]	Capture velocity [m/s]	Air velocity in duct on unfiltered side [m/s]	Filter necessary	Air velocity in outlet duct [m/s]	Chimney height [m]	Suitable Geovent products	Remark
Grinding dust bench grinder/belt grinder	150	80	-	20 - 25	Yes	8 - 10	2 m above roof ridge	Ask	
Grinding dust rotary grinder and more	100	28 - 32	-	20 - 25	Yes	8 - 10	2 m above roof ridge	HVU	
Welding smoke non-alloyed steel(TIG)	1000	160	0,5	10 - 15	No	8 - 10	2 m above roof ridge	WING, COMPACT and MEF	Demand control recommended
Welding smoke non-alloyed steel (MMA, FCA, MIG/MAG)	1000	160	0,5	10 - 15	Yes, depending on local regulation	8 - 10	2 m above roof ridge	WING, COMPACT, MEF and GeoFilter GFB	Demand control recommended
Welding smoke alloyed steel (TIG)	1000	200	0,5	10 - 15	Yes, depending on local regulation	8 - 10	2 m above roof ridge	WING, COMPACT, MEF and GeoFilter GFB	Demand control recommended
Welding smoke alloyed steel(MMA, FCA, MIG/MAG)	1500	200	0,5	10 - 15	Yes	8 - 10	2 m above roof ridge	WING, COMPACT, MEF and GeoFilter GFB	Demand control recommended
Welding smoke aluminium (MIG/MAG, TIG)	1500	200	0,5	10 - 15	Yes, depending on local regulation	8 - 10	2 m above roof ridge	WING, COMPACT, MEF and GeoFilter GFB	Demand control recommended
Laser/plasma cutting	Depending on size of cutting table [m <sup>2</sup> ]	-	1-2 m/s at cutting place	15 - 20	Yes	8 - 10	2 m above roof ridge	MEF and GeoFilter GFB	
Exhaust gases - motor < 3000 cm <sup>2</sup>	400	100	-	10 - 12	No	5 - 8	2 m above roof ridge	Hose reels GTS/GTE or Channel Duct 25	Only idle operation
Exhaust gases Motor > 3000cm <sup>2</sup>	1000	150	-	10 - 12	No	5 - 8	2 m above roof ridge	Hose reels GTS/GTE or Channel Duct 25	Only idle operation
Exhaust gases Test stand	2000	200	-	10 - 12	No	5 - 8	2 m above roof ridge	GeoFlex HT and AU2 hood	
Fumes from organic solvents and glue	2000	200	0,5	10 - 12	No	5 - 8	1 m above roof ridge	Hose reels GTS/GTE or Channel Duct 25	Fan must be EEEx-II T3
Oil mists, CNC milling machines	600	160	0,3	10 - 15	Yes	5 - 8	1 m above roof ridge	GeoFilter OIL 160	One filter per extraction point
Oil mists, conventional machines	200	100	0,3	10 - 15	Yes	5 - 8	1 m above roof ridge	GeoFilter OIL 100 and ASA-3/ASA4	One filter per extraction point
Soldering fumes	200	100	0,3	10 - 12	No	5 - 8	1 m above roof ridge	FLEXI or MINI	
Laboratory/hospital	Enquire	Enquire	Enquire	10 - 12	No	5 - 8	1 m above roof ridge	FLEXI	

