



GEOVENT

INSTRUCTION MANUAL



ESA ARM

ESA arm available in lengths 2 - 5 meter

Contents

1.0 General safety regulations	3
1.1 Dangers	3
1.2 Field of application	3
1.3 Handling	3
1.4 Technical data	4
1.4 Construction	5
2.0 Installation	5
2.1 Installation of additional equipment	8
2.2 Test run – fine tuning	8
3.0 User instruction	8
4.0 Maintenance	9
5.0 Liability	9
6.0 Declaration of conformity	10

1.0 General safety precautions

IMPORTANT – Please study all the instructions before mounting and use.

Please keep these instructions in a safe place and instruct all users in the function and operation of the product.

Do not dismantle any factory-mounted parts, since it impedes the use of the equipment.

All electrical installations must be carried out by an authorised electrician.

1.1 Dangers

By placing a hand between the gas spring and support arm you run the risk of disembodiment.

By drilling into or in any other way damaging the gas dampers you run the risk of death.

1.2 Field of application

GEOVENT ESA arm is the classic extraction arm for welding fumes, sanding dust and fumes etc. – where the focus is on the health of the operator ergonomics, and effectiveness.

The ESA arm comes with an exterior support arm and hose.

The extraction arm is not to be used in areas that categories as ATEX-zones like extraction of aluminum-, flour-, fabrics-, and wood dust as well as other explosion hazardous materials.

In case of ATEX-related processes use the ASX-arm.

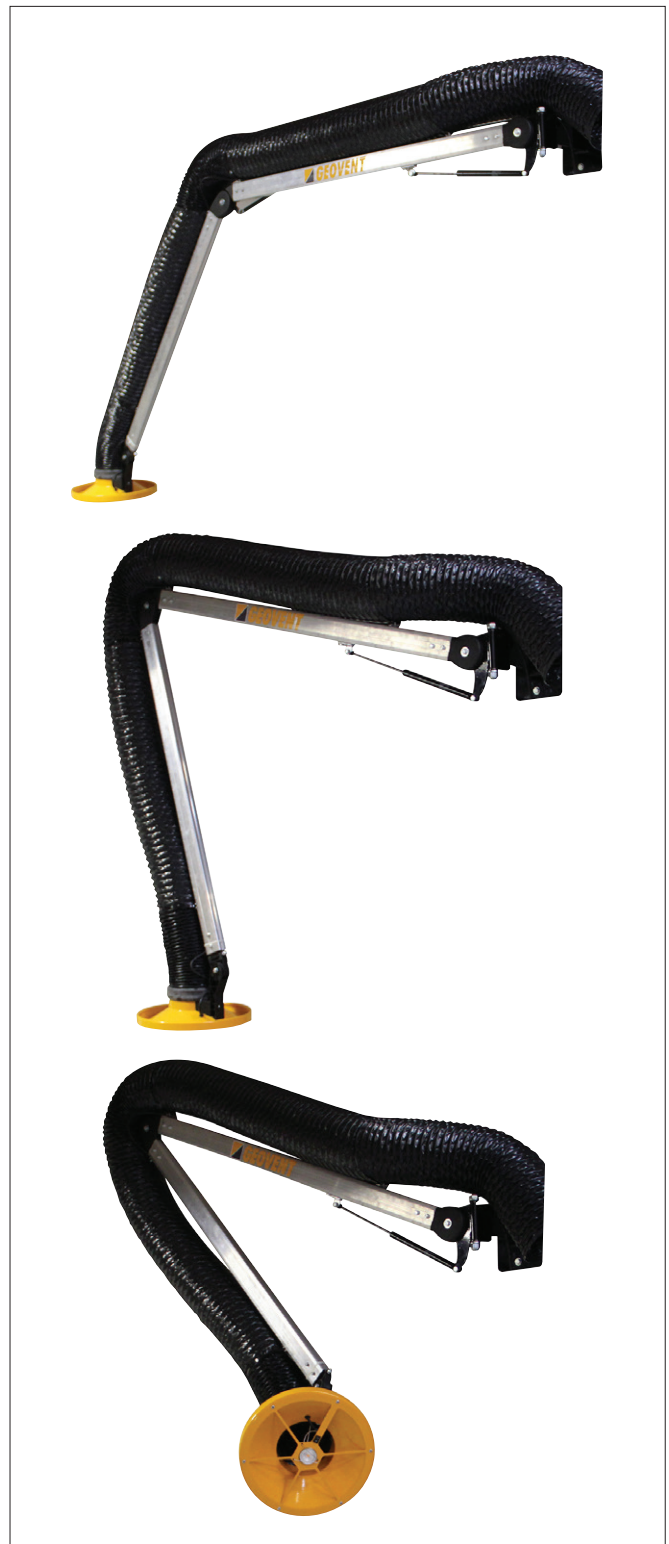

1.3 Handling

Always wear gloves when handling.

It is best handled/lifted in the aluminum arm during transport and installation. Note that it is possible to get your fingers pinched between the gas spring and the aluminum arm.

An installed arm is exclusively operated by the hood.
PLEASE NOTE. It is not allowed to rotate the hood.

1.4 Technical data

ESA Arm

Art. no.	Beskrivelse	Weight
01-650	ESA Arm 2,0m \varnothing 160 mm, complete arm incl. hose and wall bracket.	9 kg
01-651	ESA Arm 3,0m \varnothing 160 mm, complete arm incl. hose and wall bracket.	11 kg
01-652	ESA Arm 4,0m \varnothing 160 mm, complete arm incl. hose, wall bracket, and extension.	15 kg
01-653	ESA Arm 5,0m \varnothing 160 mm, complete arm incl. hose, wall bracket, and extension.	16 kg
01-660	ESA Arm 2,0m \varnothing 200 mm, complete arm incl. hose and wall bracket.	10 kg
01-661	ESA Arm 3,0m \varnothing 200 mm, complete arm incl. hose and wall bracket.	12 kg
01-662	ESA Arm 4,0m \varnothing 200 mm, complete arm incl. hose, wall bracket, and extension.	17 kg
01-663	ESA Arm 5,0m \varnothing 200 mm, complete arm incl. hose, wall bracket, and extension.	18 kg

Recommended flow area

Hose dimension:

\varnothing 160

800-1000 m³/h

\varnothing 200

1000-2000 m³/h

Length: 2, 3, 4 or 5 meters

4 and 5 meter arm is installed on an extender

Hose max. temp. 80°C

Delivery with alternative hose types possible.



ESA arm 4 meters

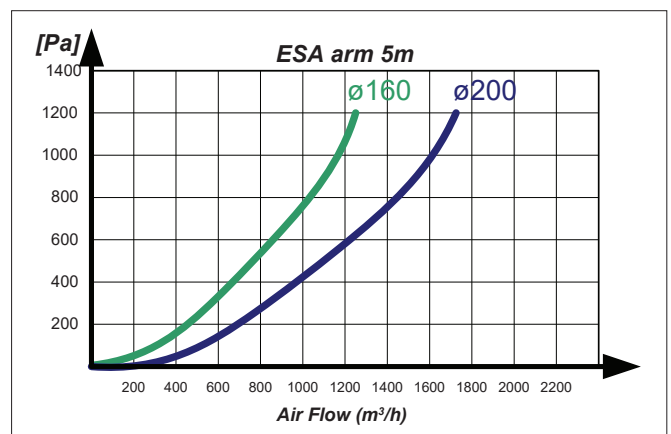
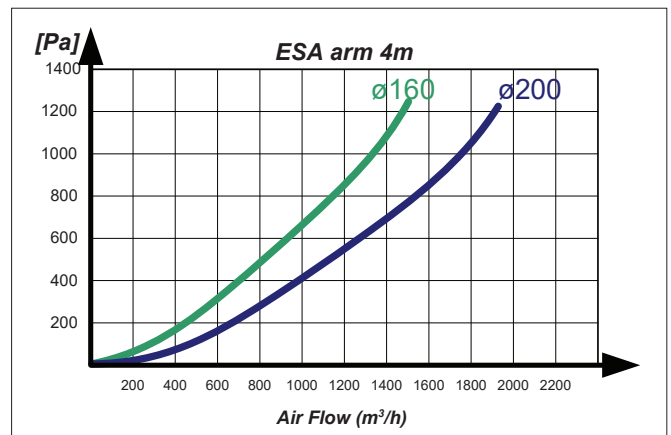
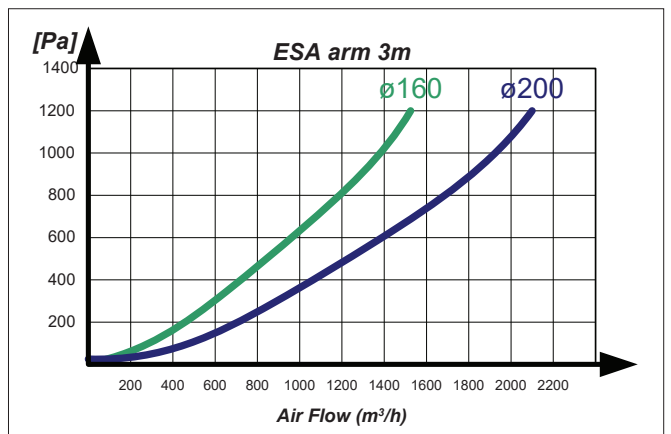
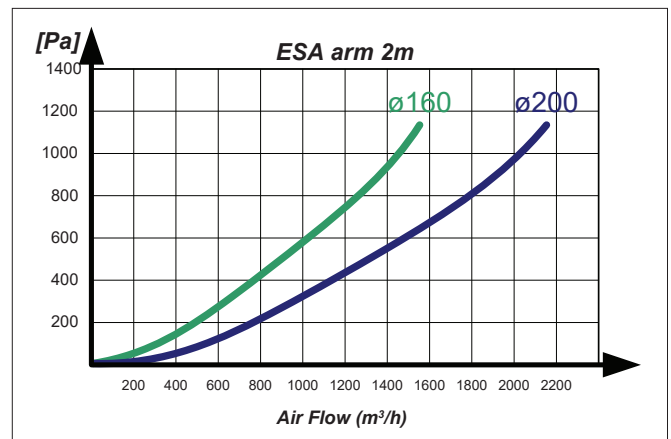

1.4 Construction

Wall bracket: Powder coated steel bracket in black RAL 9005.

Hood: Lightweight-aluminum hood $\varnothing 160$ or $\varnothing 200$ mm. The hood is powder coated in RAL 1007. LED light is to be ordered.

Arms and friction joints: The ESA arm is constructed in extruded 6060 aluminum profile with injection molded joints - made from plastic - and gas dampers in the 2 joints for easy control.

Hose: Black PVC-hose with steel spiral (GeoFlex P2A 1000).

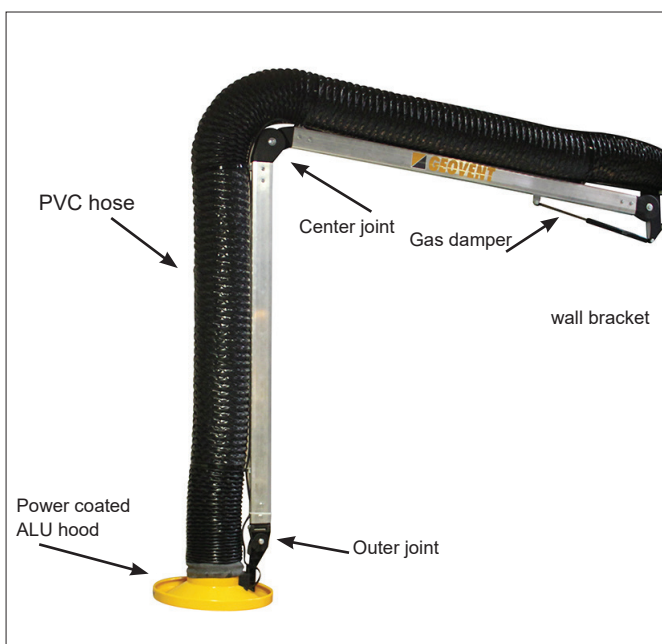

2.0 Installation

The ESA arm is delivered partially assembled and consists of 1 partially assembled support arm with wall bracket, 1 hood as well as 1 set of hose, clamps, and rubber bands.

Specifications of variations of the product will be visible on the order confirmation/invoice.

The following should be taken into consideration before installing:

- Adequate room for a satisfactory use of the arm.
- Optimal installation height for the task at hand.
- The possibility of connecting to pipework and optional automation.

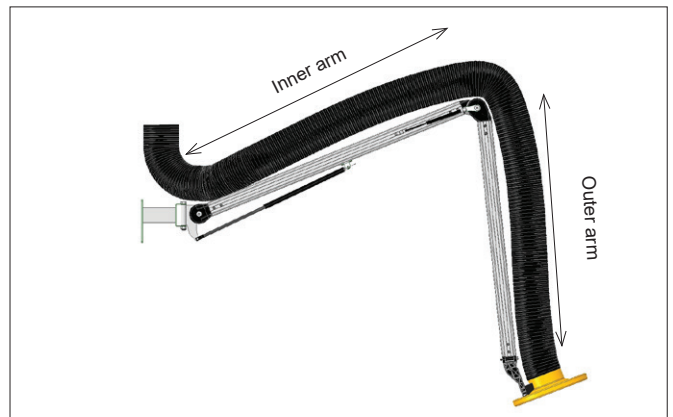

ESA Arm	Inner arm (mm)	Outer arm (mm)	Extension (mm)	Max. Working radius (mm)	Max. Radius (mm)
2M	865	696		1600*	2000
3M	1365	1200		2700**	3000
4M	1365	1200	1000	3700**	4000
5M	1365	1200	2000	4700**	5000

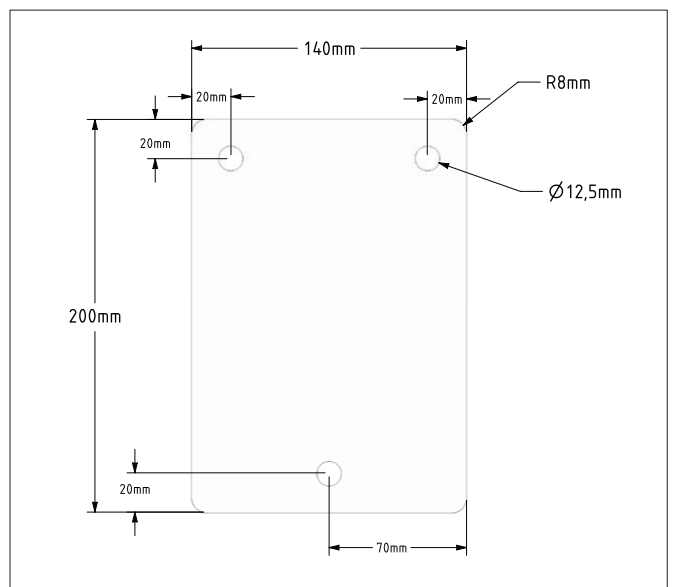
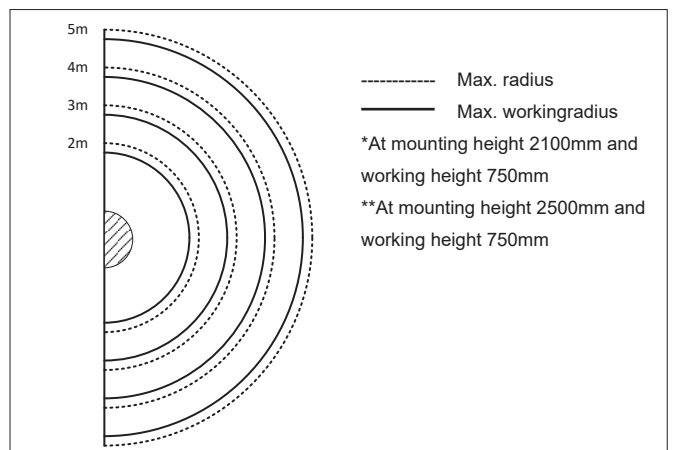

Wall bracket

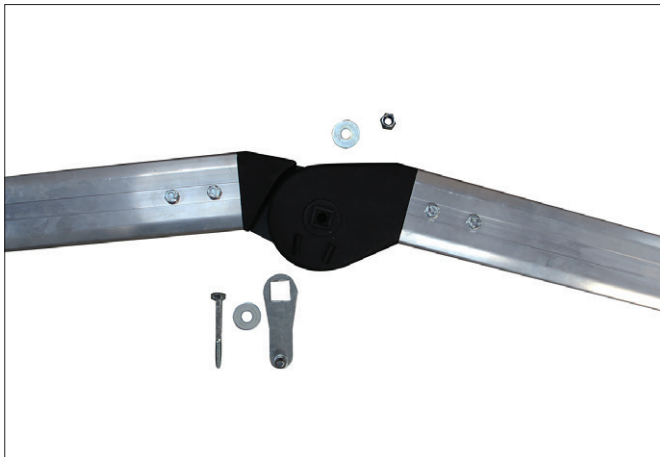

1. Begin by assembling the arm.



2. The center joint of the arm is attached by tightening the bolt and nut before clicking the gas damper into place.

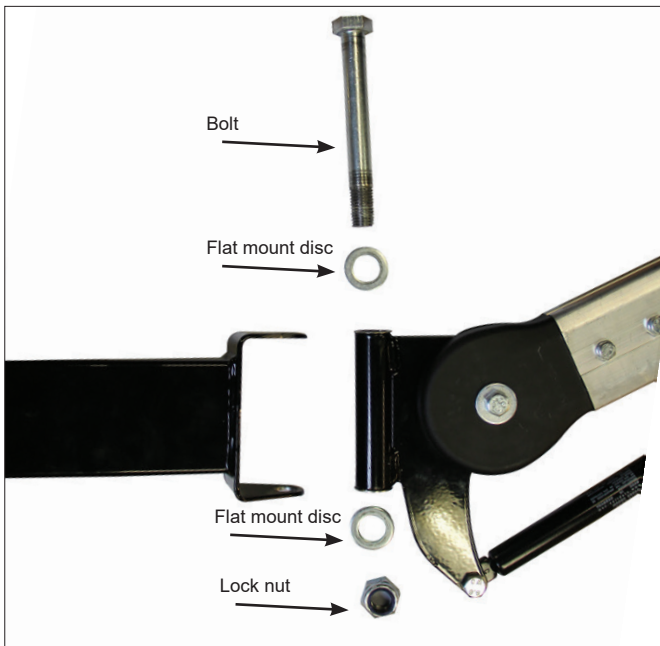

3. Once the wall bracket is installed on the wall, the arm is mounted. At the top of the inner joint the bolt, flat mount disc, and the lock nut is fitted. See image. Tighten as needed.

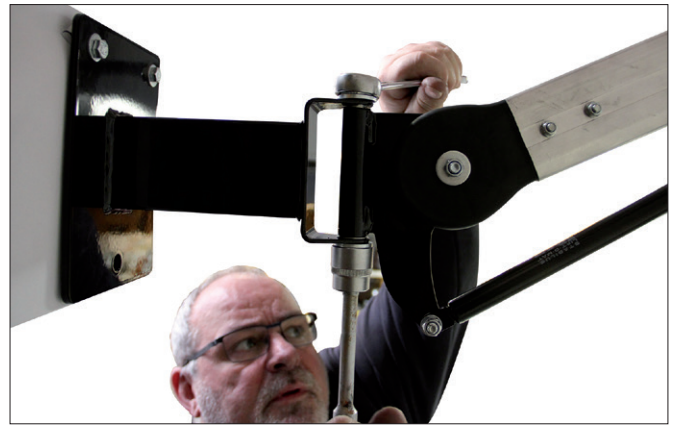

4. Use the correct tool to secure the arm to the wall bracket. Tighten as needed.



5. Firstly Install the rubber bands, then tighten the band clamp so that the hose is properly secured to the hood. Afterwards place the rubber band over the hose and band clamp.



6. Before the hose is installed onto the arm, it is important that the hood is in the position, where the hose is stretched the most. Afterwards place the cable tie inside the retainer and tighten it gently.



7. The cable ties should not be tightened all the way until the entire hose is installed onto the arm.

Instructions for 4 meter and 5 meter ESA arms

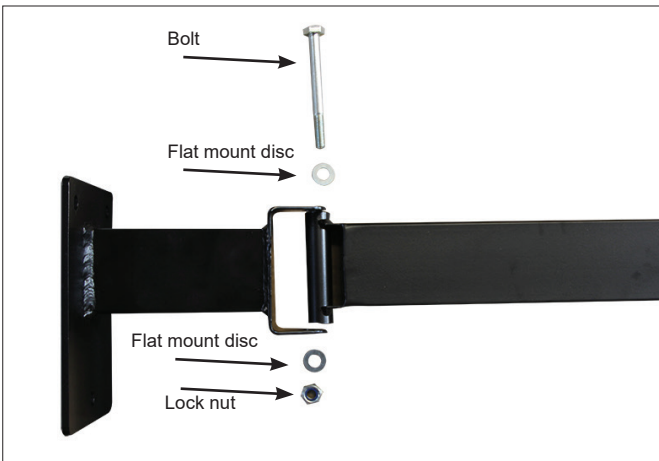

1a. Begin by installing the extender onto the wall bracket.



2a. Tighten as needed.



3a. When the extender is installed onto the wall bracket the arm is mounted. At the top of the inner joint the bolt, flat mount disc, and the lock nut is fitted. See image for reference.



4a. Tighten as needed.

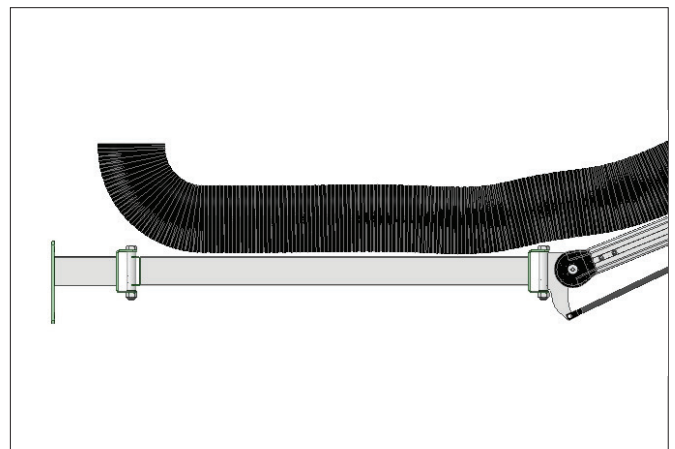

5a. Secure the hose onto the extender with the supplied cable ties.

Continue with instruction nr. 5, 6 and 7 on page 6.

2.1 Installation of additional equipment

Installation of lights

Lights and net needs to be installed from the factory. The connection is made by routing the wire through the hose all the way to the wall. Connect the wire to the power supply (230V → 12V), and connect this to the power grid.

Specifications for the light:

Type:	LED
Effect:	5 W 36°
Voltage:	12 V
Recommended trafo-effect:	70 W

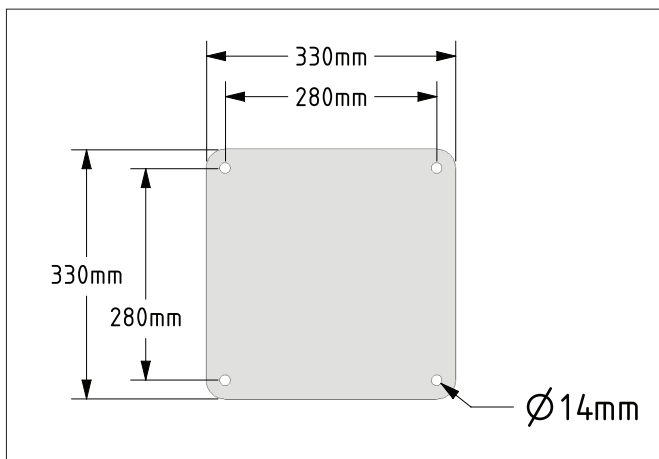

Ceiling console



2.2 Test run – fine tuning

For optimal performance of the arm it should be adjusted after the installation is completed, to ensure that it is adjusted to the typical working area. This is done by adjusting the swivel points mentioned in step 2 with two 13 mm spanners.

3.0 Usage – User manual

The arm must be operated by the hood. Do not pull the arm or the hose. Please be aware that it is possible to pinch your fingers at the gas damper. The hood must not and cannot be rotated.

Under normal use the arm is be able to support itself in the desired position within the working area. The arm has 180° rotatable working area.

It is possible to damage the hose and make it leak by straining it from the outside with e.g. a screwdriver. This should therefore be avoided in order to guarantee the longest possible life time.

Under normal circumstances the arm's hood should be placed 300-500 mm vertically above the spot, where welding is done, meaning right above the source of pollution. This ensures that up to 99% of the polluting particles are captured.

Optimal welding situation:

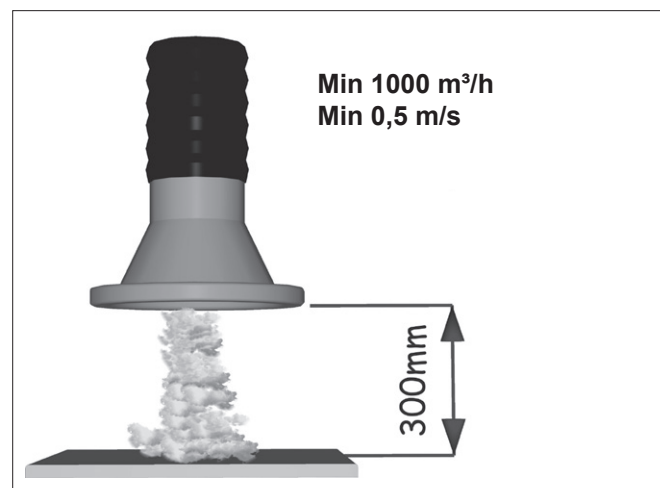

Less optimal welding situation:

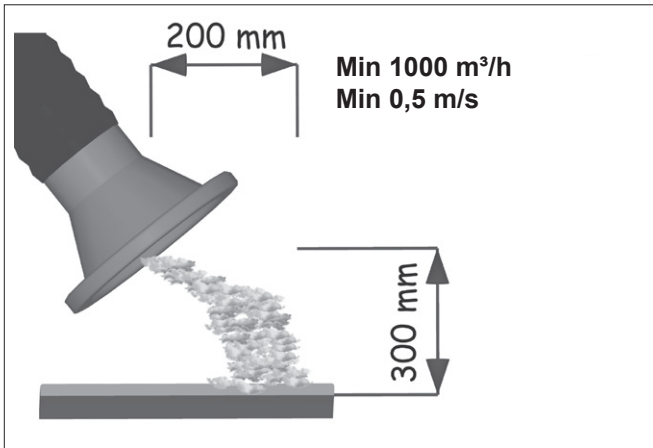

Always check that the correct amount of air is extracted at the extraction hood.

The arm will not function properly if...

- any unauthorized parts are installed onto the arm (e.g. a power outlet on the hood).
- you push the arm towards the desired position. Instead, move the arm to the desired position and wait a moment until the arm's friction discs has locked the arm into place. If this does not work tighten the loose joint with two 13 mm spanners.
- if anything else than the arm is suspended from the extension arm. It is only meant to carry the weight of the arm.

4.0 Maintenance

Periodic maintenance

- If the arm cannot stay in position e.g. if it moves from the desired position, you will need to adjust the joints (see step 2).
- Inspect the state of the hose and spring as well as the friction discs. Replace these if necessary. Contact your dealer for spare parts.

The local exhaust ventilation system should be inspected by an authorized service-technician at least once a year.

5.0 Liability

Warranty

Geovent A/S grants a warranty for products, which are defective, when it can be proved that the defects are due to poor manufacture or materials on the part of Geovent. The warranty comprises remedial action (reparation or exchange) until one year after the date of shipment.

No claims can be made against Geovent A/S in relation to loss of earnings or consequential loss as a result of defects on products from Geovent.

Wear on parts such as filter cartridges and hose is not included in the warranty.

User liability

In order for Geovent to be capable of granting the declared warranty, the user/fitter must follow this Instruction Manual in all respects.

Under no circumstances may the products be changed in any way, without prior written agreement with Geovent A/S.

6.0 Declaration of conformity



HOVEDGADEN 86 • DK-8831 LØGSTRUP
(+45) 8664 2211 • salg@geovent.dk

The manufacturer: GEOVENT A/S
HOVEDGADEN 86
DK-8831 LØGSTRUP

Hereby declares that:

The product: Extraction arm
Models: ESA arm (ø160 mm - ø200 mm)

has been manufactured in compliance with the following directives and standards:

European Parliament and Council Directive 2006/42/EC of 17 May 2006 on machinery, and amendments to Directive 95/16/EC.

EN ISO 14121-1:2007 Risk assessment – part 1

EN ISO 12100-1:2005 Basic concepts and general principles for design.

EN ISO 12100-1:2009 construction and design
Part 1: Basic terminology and methodology

EN ISO 12100-2:2005 Basic concepts and general principles for design.

EN ISO 12100-2:2009 Construction and design
Part 2: Technical principles

Authorized to collect the technical file:

Lise Cramer

Date: 1/10-19

Position: Director
Name: Thomas Molsen

Signature:





GEOVENT

HOVEDGADEN 86 • DK-8831 LØGSTRUP
(+45) 8664 2211 • salg@geovent.dk