

114530EN-05
2016-11

C2



A

EN **User instructions**
Ceiling mounted air handling unit
and automatic control system

ART. NO.:
700030
700031
700032
700033



SAFETY INSTRUCTIONS

- It is the installer's responsibility to carry out a full safety and function assessment of the appliance.
- To reduce the risk of fire, electric shock or injury, read all the safety instructions and warning texts before using the unit.
- This unit is only designed for ventilation air in homes and commercial buildings.
- It must not be used to extract combustible or flammable gases.
- Remove the power plug before commencing any service and maintenance work.
- Before opening the door: switch off the heat, let the fans continue for 3 minutes to remove hot air, unplug the unit and wait 2 minutes before opening the doors.
- If the power lead is damaged, it must be replaced by the manufacturer, the manufacturer's service agent or a similarly qualified person.
- The unit contains heating elements that must not be touched when they are hot.
- The unit must not be operated without the filters being in place.
- Do not heat any combustible substances under the cooker hood if one is installed.
- Do not leave a saucepan or frying pan containing oil or fat unsupervised when using a cooker hood.
- Warranty claims will only be valid if the instructions in the manuals have been followed.
- To maintain a good indoor climate, comply with regulations and avoid condensation damage, the unit must never be stopped apart from during service/maintenance or in connection with an accident.
- All electrical connections must be carried out by qualified electricians.
- All plumbing work must be carried out by an authorised plumber.
- The water battery must be located in a room with a drain.



When servicing ceiling-mounted air handling units, there is a risk of components falling down.

This appliance may be used by children of 8 years or above or by persons with reduced sensory capacity or reduced physical or mental capacity, or by persons with lacking experience or knowledge, provided they have received instructions in the safe use of the appliance or are supervised to ensure safe use and providing they are aware of the risks. The product is not suitable for use by children.

Children must not be allowed to play with the appliance. Children must not carry out cleaning or maintenance without supervision.

Our products are subject to continuous development and we therefore reserve the right to make changes.

We disclaim all liability for printing errors.

See the following documents for more information on the product:

114531 Spare parts list
 114537 Wiring diagram without electric battery
 114536 Wiring diagram with electric battery
 110827 CI60
 110828 CI600



Contents

1	How to read the document	4
2	Functional description of balanced ventilation	5
2.1	Fans (M1, M2)	5
2.2	Filters (F11, F12)	5
2.3	Rotor (HR-R)	5
2.4	Heating element (EB1)	5
2.5	Temperature sensors (B1, B4)	5
3	Operating the door	6
4	Overview of CI60 control panel	7
5	CI60 in use	8
5.1	General	8
5.2	Increasing/reducing the air supply	8
5.3	Adjusting the air supply	8
5.4	Adjusting the temperature	8
5.5	Changing the filters	8
5.6	Alarm	8
5.7	Resetting	9
6	Overview of CI600 control panel	9
7	CI600 in use	10
7.1	General	10
7.2	Idle mode	10
7.3	Menu navigation	10
7.4	Startup	10
7.5	Operating status	10
8	CI600 main menu	11
8.1	Fan speeds	11
8.2	Max. timer	11
8.3	Settings	11
8.4	Temperature	11
8.6	Daily/weekly timer	12
8.5	Timer	12
8.7	Time and date	13
8.8	Language	13
8.9	Filter	13
8.10	Alarm	13
8.11	Operating information	13
9	CI600 advanced user menu	14
9.1	PIN	14
9.2	Advanced user	14
9.3	Temperature regulation	14
9.4	Fan control	15
9.5	Idle mode	16
9.6	Operating time	17
9.7	Service	17
9.8	Menu tree	18
10	Cleaning and maintenance	19
10.1	Changing the filters	19
10.2	Cleaning the fans	20
10.3	Changing the brush strips	21
10.4	Cleaning the rotor	22
10.5	External cleaning	22
11	Maintenance table	23
12	Troubleshooting	23
13	CE Declaration of Conformity	25

1 How to read the document



NB! When a text bears this symbol, damage to equipment or poor efficiency may be the consequence of not following the instructions.



CAUTION! When a text bears this symbol, it means that personal injury or serious damage to the equipment may result if the instructions are not followed.

Symbols used

These products have a number of symbols that are used to label the product itself and in the installation and user documentation.



Supply air



Extract air



Kitchen air



Exhaust air



Outdoor air



DANGER!
ELECTRICITY



DANGER! DO NOT TOUCH

2 Functional description of balanced ventilation

2.1 Fans (M1, M2)

The fans ensure that air enters and leaves the building. They can be individually adjusted for optimal operation. The unit can be regulated at three different speeds via the control panel: Min, Normal and Max.

2.2 Filters (F1, F2)

Filters with a high filter grade (F7) are used as standard for both supply air and extract air, so that the air which enters the building is clean. The filters also ensure that the unit stays clean and can maintain thermal efficiency and air flow.

2.3 Rotor (HR-R)

The air passes through the rotary heat exchanger (recovery system). The rotor functions as a heat magazine. The heat from the extract air heats up one part of the rotor. When the heated part comes over to the supply air side, the heat is transferred to the supply air.

2.4 Heating element (EB1)

If the energy recovered from the extract air is insufficient to maintain the set supply air temperature, an electric heating element will help raise the temperature. The heating element is protected against overheating by the thermostat (F20) which cuts out at high temperature. For extra safety, the thermostat (F10) cuts out at critical temperatures. (The F10 thermostat must be reset manually by pressing the reset button.)

2.5 Temperature sensors (B1, B4)

As standard, the unit has two temperature sensors. Supply air sensor (B1) records the temperature after the heating battery. Outdoor air sensor (B4) registers the temperature of the outdoor air.

 Adjustment must always be carried out by qualified personnel before the installation is used for the first time.

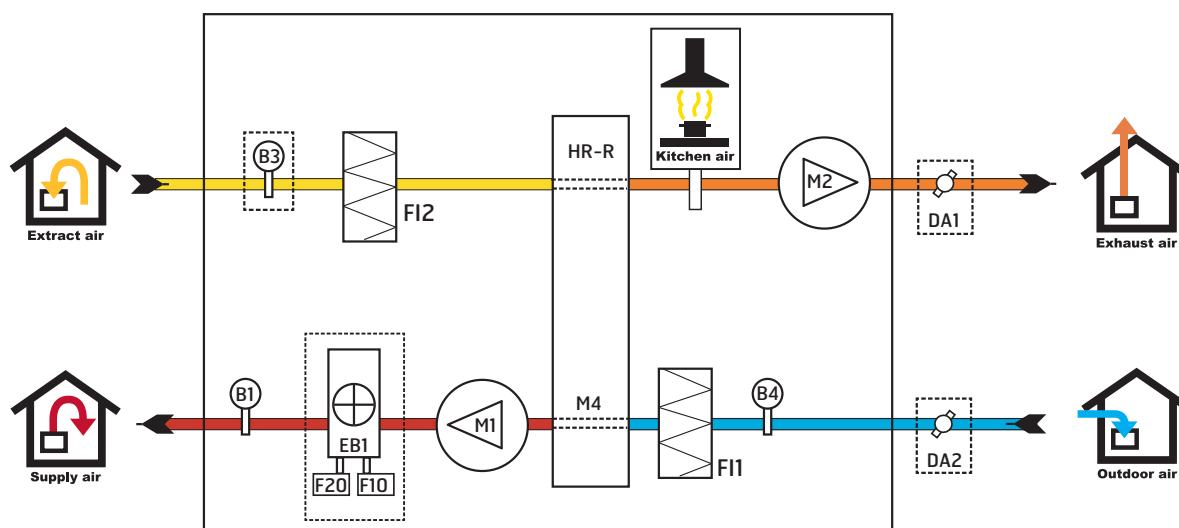

3 Operating the door

Mount the safety strap as shown on **figure 1**.



When the unit is located on the floor, this strap must always be mounted. We also recommend its use for ceiling mounting.

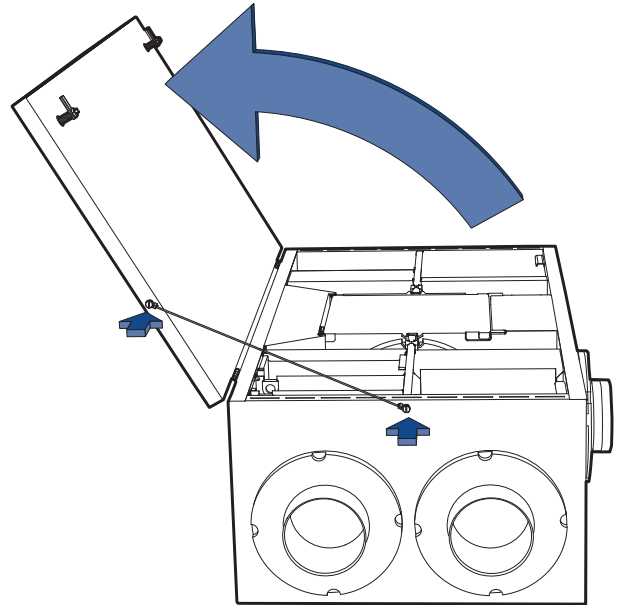

figure 1 Fix the safety strap

1. Unscrew the screw from the lock
2. Flip up the lock handle
3. Turn the lock handle and rotate it 90 degrees.

The door may now be opened.

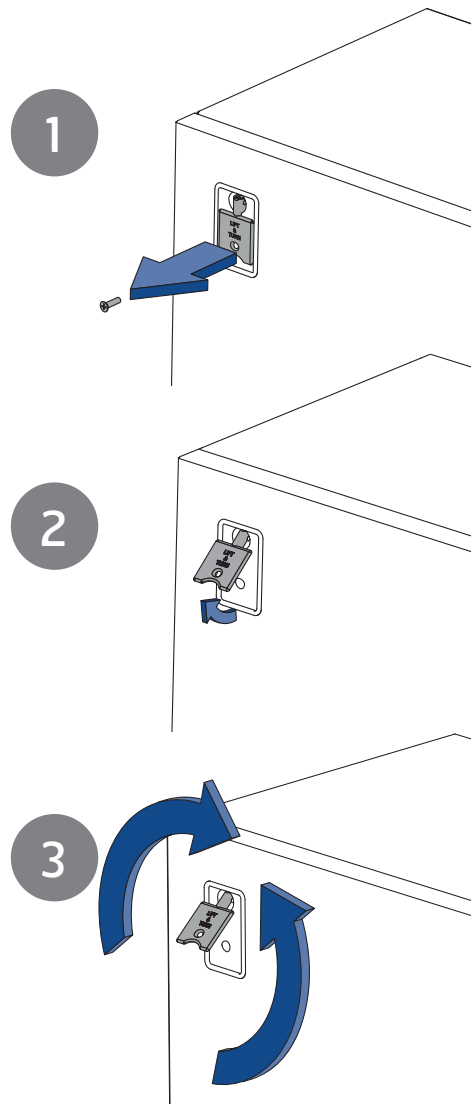
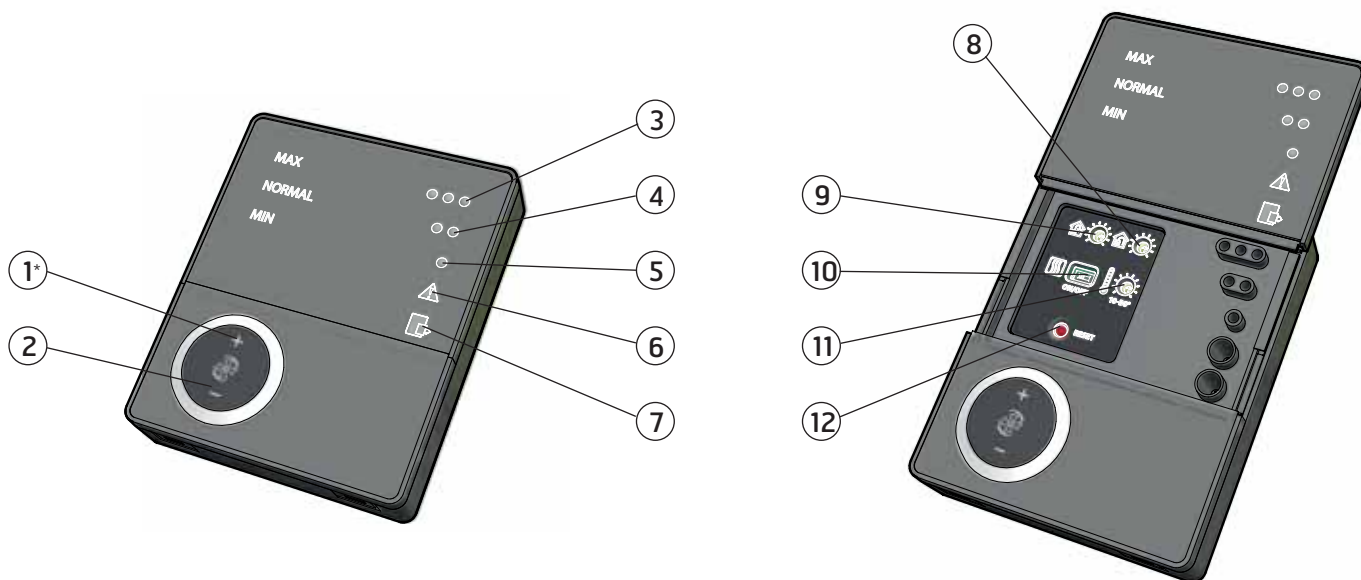

figure 2 Open the door lock

4 Overview of CI60 control panel



No.	Description
1*	Switch for increased ventilation
2	Switch for decreased ventilation
3	Indication for MAX speed
4	Indication for NORMAL speed
5	Indication for MIN speed
6	Indication for ALARM
7	Indication for FILTER CHANGE

No.	Description
8	Potentiometer for adjusting extract air at NORMAL speed
9	Potentiometer for adjusting supply air at NORMAL speed
10	Switch for additional heating ON/OFF
11	Potentiometer for adjusting supply air temperature
12	Switch to reset alarm

Nos. 8, 9 and 10 are used to adjust the unit before it is used for the first time.

*The numbers are used as references in subsequent descriptions

5 CI60 in use

5.1 General

The control unit consists of pressure switches, LEDs for indication, plus knobs and switches for adjusting the ventilation unit. The control unit communicates with the ventilation unit via a low-voltage cable.

5.2 Increasing/reducing the air supply

Use switches 1 and 2 to increase and reduce the fan speed and with it the air flow rate. The following speeds are used depending on the operating situation.

MIN	Must not be used when the home is in use. Must not be used in the first year of operation.
NORMAL	Used under normal conditions. On this setting the air supply must be adjusted according to current regulations.
MAX	Used if there is a need for increased air supply on account of higher occupancy or a raised humidity level, for example during showering or when clothes are being dried. This setting is normally used for limited periods.

The different speeds are indicated by LEDs 3, 4 and 5.

5.3 Adjusting the air supply

At NORMAL speed level, the air flow must be adjusted according to project data. Potentiometer 9 is used for the supply air level and potentiometer 8 for the extract air level. The adjustment range is 20-100% of the maximum level according to the scale of the potentiometer.

Factory settings:

MIN	50% (fixed)
NORMAL	75% (variable)
MAX	100% (fixed)

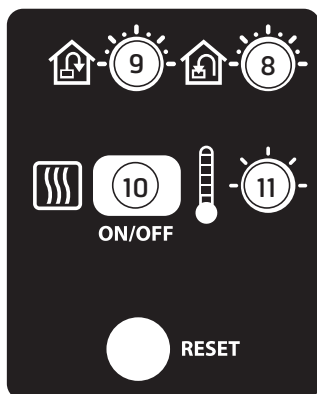

5.4 Adjusting the temperature

The temperature required for the supply air can be set with knob 11. The adjustment range is 10-30°C. Use of the factory settings is recommended.

If necessary, the ventilation unit's heating can also be switched ON/OFF with switch 10. In this case only the rotating heat exchanger is used as a source of heat. It is best to leave it in ON position, as the unit will then respond automatically when there is a need for additional heating.

Item 10

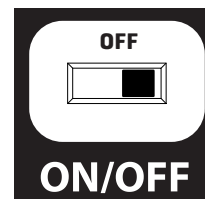
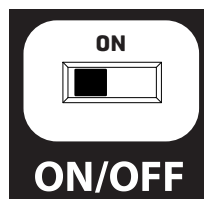

5.5 Changing the filters

LED 7, which is yellow, lights up every six months as a reminder that it is time to change the air filters in the unit. See **10.1 Changing the filters** for more information on changing filters.



Once the activity has been carried out, the indicator must be reset. See more under the section on resetting.

5.6 Alarm

If anything unforeseen occurs with the ventilation unit, indicator 6 will light up. The indicator signal will depend on the reason for it coming on.



A steady light indicates:

- Error on return water sensor (B5)
- Error on heat recovery (B alarm)

Steady light with flashing MIN speed (indicator 5) indicates:

- Error on supply air sensor (B1)
- Error on extract air sensor (B3)
- Error on outdoor air sensor (B4)

A flashing light indicates:

- Overheating thermostat fault (applies only to electric heating)
- Fault in external fire/smoke detector (accessory)
- Error on heat recovery (A alarm)
- Error on water battery (applies only to electric heating)

5.7 Resetting

Once the filter has been changed or the cause of the alarm rectified, the alarm must be reset. This is done by pressing switch 12.

If the indicator goes out, the action has been carried out correctly. If the indicator remains on, the fault has not been rectified correctly.

NB! If thermostat F10 trips, the unit will have to be opened up and physically reset before resetting on the panel. If the alarm trips repeatedly, contact the service company or distributor.

6 Overview of CI600 control panel



No.	Description
1*	UP/INCREASE switch
2	BACK/CANCEL/NO switch
3	DOWN/DECREASE switch
4	OK/YES switch
5	HELP switch
6	Display
7	Indication for OPERATION/OK -Green light
8	Indication for FILTER CHANGE -Yellow light
9	Indication for ALARM -Red light

*The numbers are used as references in subsequent descriptions

7 CI600 in use

7.1 General

The control unit consists of a colour display, pressure switches and indicators (LEDs). See figure on left for more information. The unit communicates with the ventilation unit via a low-voltage cable.

7.2 Idle mode

The panel will go into idle mode if it is not used for a while. Operating information is displayed in idle mode. The panel will come out of idle mode if one of the buttons is pressed.

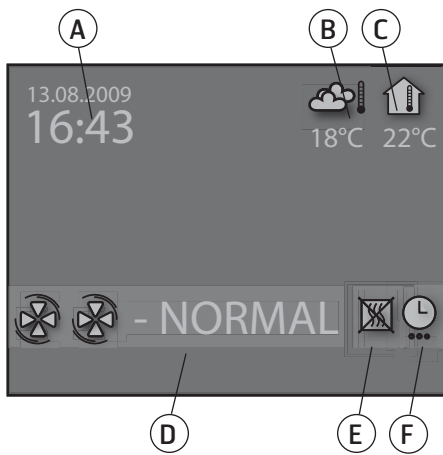

- A. Time and date
- B. Outdoor air temperature
- C. Room temperature
- D. Current speed
- E. Additional heating activated/deactivated
- F. Daily/weekly timer active

7.3 Menu navigation

To navigate the menu rows, use buttons 1 and 3. The cursor is illustrated by the row turning light-blue. If it is possible to make a selection on the current menu line, this is displayed with OK? to the right of the line. A selection is confirmed by pressing button 4. If a menu line contains submenus, this is illustrated with a ">" sign at the end of the line.

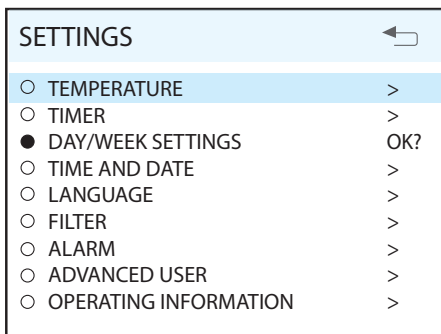

If you select a function that has numerical values, the current value is displayed with a light blue cursor. The value is changed with buttons 1 and 3 and then confirmed by pressing button 4.

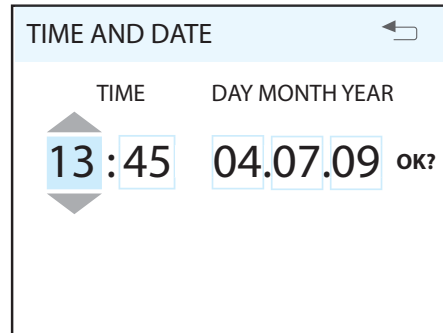

If several values can be changed, the cursor will skip to the right when a choice is confirmed with button 4. The procedure will repeat until all values have been changed to the desired values.

If you want to cancel a function or return to the previous menu screen, use button 2.

Button 5 activates a help text that briefly describes the current menu screen.

7.4 Startup

When the system is started, a special startup menu is opened.

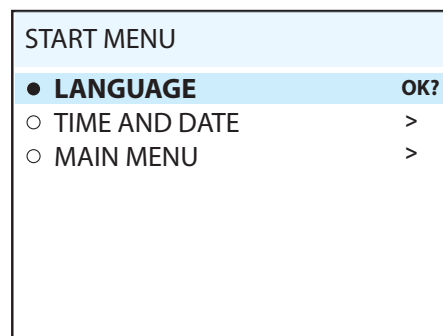

The basic language and date settings are set in this menu. When this activity has been carried out, you choose to go to the main menu.

7.5 Operating status

In normal operation without problems, the green LED 7 lights up to confirm that everything is working normally. How any problems affect the system is described in subsequent sections.

8 CI600 main menu

8.1 Fan speeds

The main menu contains various choices. Most concern fan speeds. The speed selected is indicated with large fan symbols and bold text.

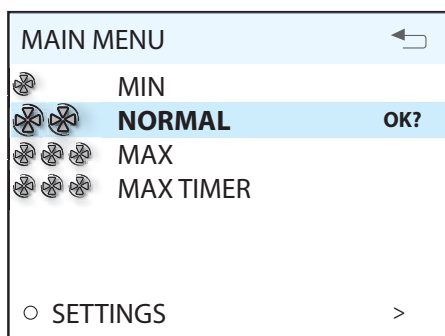

To change the speed, move the cursor with buttons 1 and 3.

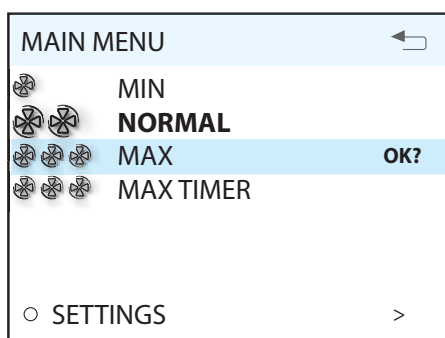

Then confirm your selection with button 4 and the speed selected will be highlighted with large fan symbols and bold font.

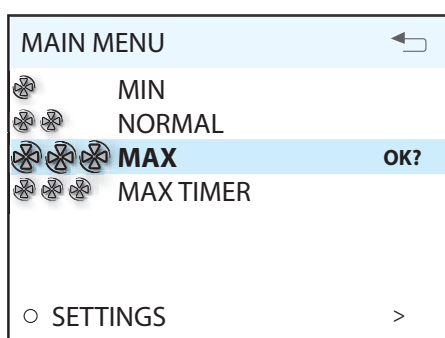

MIN	Must not be used when the home is in use. Must not be used in the first year of operation.
NORMAL	Used under normal conditions. With this setting, the air supply must be adjusted according to current regulations.
MAX	Used if there is a need for increased air supply on account of higher occupancy or a raised humidity level, for example during showering or when clothes are being dried. This setting is normally used for limited periods.

8.2 Max. timer

This menu item activates a function that increases the speed to MAX for a limited period before returning to the speed selected previously. The period of time can be adjusted under the SETTINGS menu item. This function is ideal during showering, for example, when there is a greater need for extraction for a limited period.

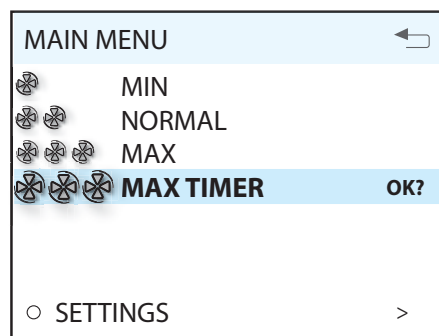

When the function is active, the time is counted down on the display. If you select TIMER OFF, the function will be cancelled and the speed will return to the previous selection.

8.3 Settings

Under the SETTINGS menu item, you can adapt the system as you want.

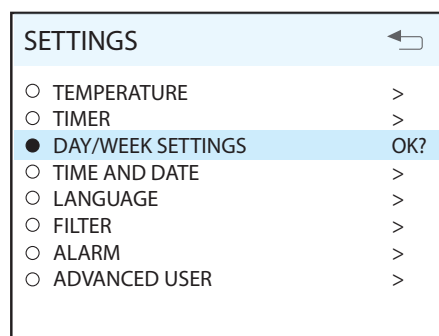

8.4 Temperature

This is where the desired temperature of the supply air is set.

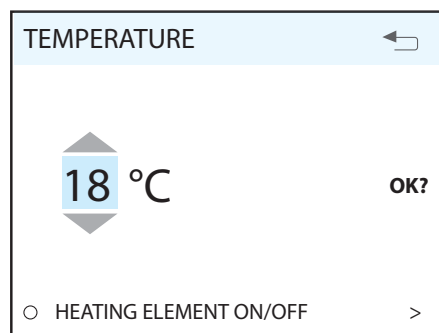

A good rule is to adjust the temperature to max. 18° so that the air is mixed optimally with the air already in the building.

In the HEATING ELEMENT OFF/ON menu item, the additional heating in the ventilation unit can be switched off. In such case, only the rotating heat exchanger is used as a source of heat.

If necessary, the ventilation unit's heating can also be turned off. In this case only the rotating heat exchanger is used as a source of heat. It is best to leave it ON, as the unit will then respond automatically when there is a need for additional heating.

NB! This does not apply if the unit has a water battery.



If the heating element is switched off, this symbol is displayed when the display enters idle mode.

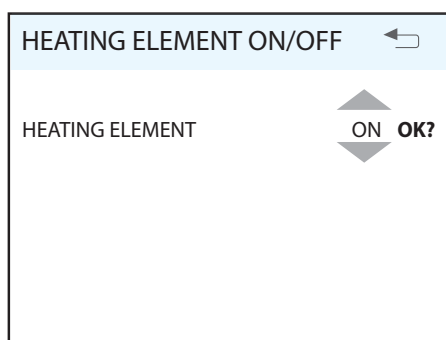

8.5 Timer

Here you set the time you want for the MAX TIMER function. This is used when the function is activated from the main menu.

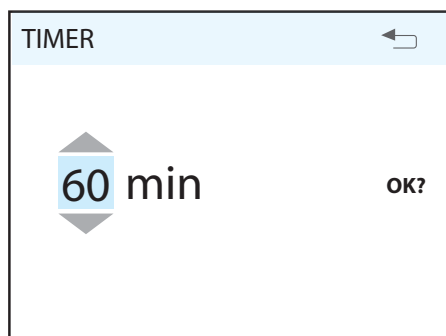

To adjust the time interval for MAX TIMER, see chapter 9.4 under "Timer".

8.6 Daily/weekly timer

Programming the timer begins with selecting the day.

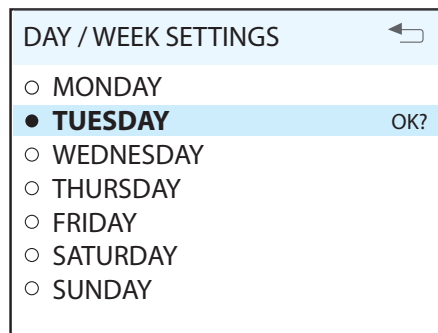

A new menu screen appears under each day.

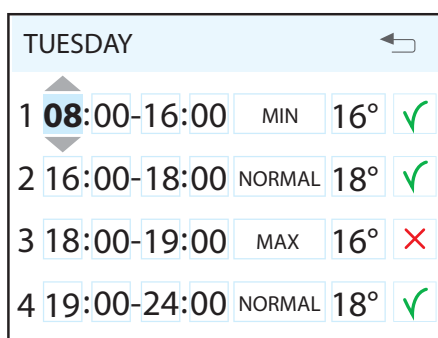

Each day can be programmed with four different time intervals. Adjust the start and stop times for each interval and then adjust the desired speed and temperature. To activate the interval, select a green tick. The interval will then be active for the selected time and day of the week. A red cross means that the interval has not been activated. If necessary, select another interval and repeat the procedure.



The following rules apply to the programming:

- An interval can never be started before the previous one has ended.
- The stop time can never be before the start time.

Once you have finished programming a day, repeat the procedure for the other days.



When the timer is active, this symbol is displayed when the display enters idle mode.

If there is no new time interval registered after the finished period, the speed and temperature return to the setting that was previously active.

8.7 Time and date

The time and date can be adjusted in this dialogue.

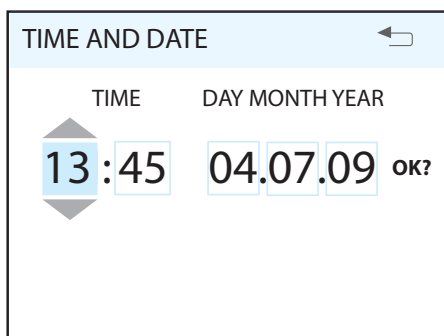

8.8 Language

The language selected can be changed in this dialogue

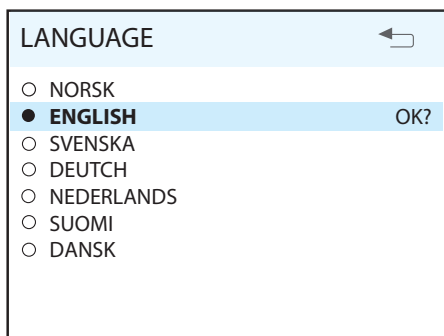

8.9 Filter

A reminder appears regularly on the display. In this dialogue, the time interval can be adjusted and the filter alarm reset.

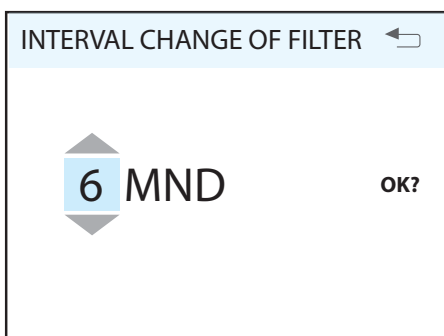
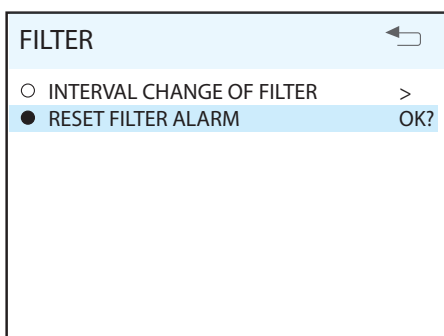

The normal time is 6-12 months, depending on the environment.

When the filter alarm is tripped, the yellow indicator 8 lights up and an information text appears. Follow the instructions in the text. It is possible to go directly to this dialogue from the message or via the menu tree. After the alarm has been reset, the countdown to the next filter change begins.

8.10 Alarm

If a problem occurs in the operation of the ventilation unit, an alarm will be tripped. The red indicator 9 lights up and an information text appears in the display. Follow the instructions in the text. It is possible to go directly to this dialogue from the message or via the menu tree.

NB! If thermostat F10 trips, the unit will have to be opened up and physically reset **before** resetting on the panel. If the alarm is tripped repeatedly, contact the service company or distributor.

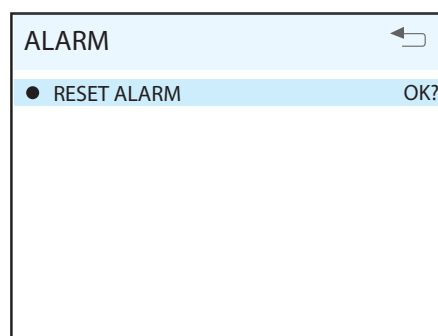

8.11 Operating information

This general screen displays current temperature values, whether the daily/weekly timer is active and activity as 0-100% for cooling, heat exchanger and additional heating.

OPERATING INFORMATION	
SET TEMPERATURE	22°
DAY / WEEK SETTINGS	AKTIV
SUPPLY AIR	22°
EXTRACT AIR	21°
OUTDOOR AIR	0°
RETURN WATER	35°
HEAT RECOVERY SYSTEM	100%
COOLING	0%
HEATING	100%

9 CI600 advanced user menu

 For more information on the “Advanced User” menu see “CI600 Reference Manual” on Flexit’s website.

9.1 PIN

To access the menu item, you need to enter the PIN 1 0 0 0.



9.2 Advanced user

This menu contains functions for monitoring, configuration and troubleshooting. Information to do with adjustment can be found in the installation instructions. Complete documentation of all menus, including configuration for accessories and extras, etc., is described in the CI600 reference manual, which is available at www.flexit.no.

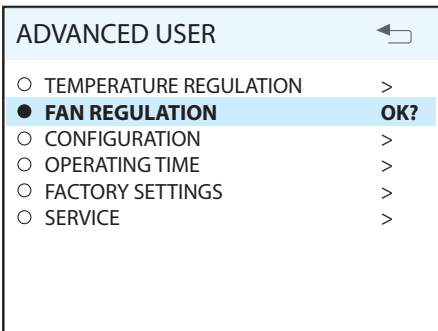

9.3 Temperature regulation

In this menu screen, you configure the temperature regulation and cooling functions.

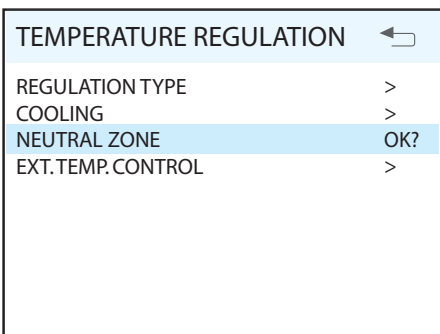

Regulation type

If supply air regulation is selected, no further settings can be set here. If extract air regulation is selected, the max. and min. supply air temperatures can also be specified.

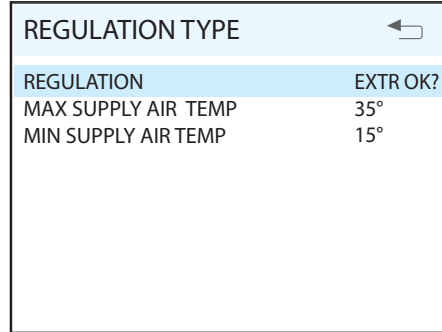

Cooling

 **NB!** Flexit does not supply or project cooling machines.

In this dialog, the cooling function is activated and the parameters MIN OUTDOOR AIR TEMP for supply of cooling and MIN SPEED for supply of cooling are specified. If a DX cooling machine is used, the supply delay interval can be specified.

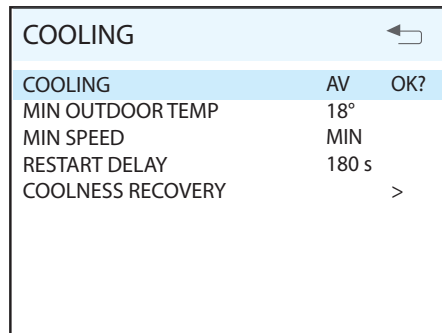

It is also possible to activate a function to recover cooling in the building using the rotating heat exchanger. Enter the desired difference between the outdoor and indoor air temperatures for when the function is activated.

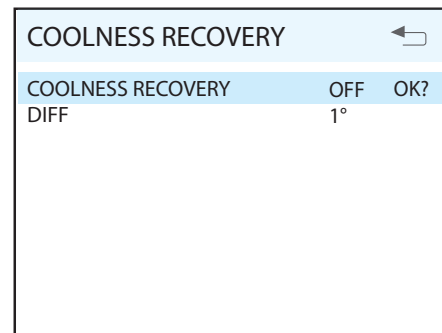

Neutral zones

To achieve more even temperature regulation, the neutral zones can be set in this menu.

NEUTRAL ZONE		
COOLNESS RECOVERY	2°	OK?
HEAT RECOVERY SYSTEM	1°	

External temperature control

Control of the temperature settings from an overall system must be entered in this menu. In this case, the temperature settings in the control unit are overridden.

EXT. TEMP. CONTROL		
EXT. TEMP. CONTROL	OFF	OK?

9.4 Fan control

The fans are selected and configured in this menu screen.

FAN REGULATION		
SUPPLY AIR	>	
EXTRACT AIR	>	
TIMER	OK?	
AIR VOLUME COMP	>	

Adjustment (supply air and extract air)

This dialog is identical for the supply air and extract air fans. The fans are adjusted individually to the desired capacity for the respective speed.

SUPPLY AIR		
MIN SPEED	50%	OK?
NORMAL SPEED	75%	
MAX SPEED	100%	

Factory settings:

MIN	50%
NORMAL	75%
MAX	100%

Timer

Settings are entered in this menu for the speed and time that are to apply to the "MAX TIMER" function in the main menu.

TIMER		
STANDARD SPEED	MAX	OK?
STANDARD TIME	30 m	

Air flow rate compensation

This function can be activated via an input on the control card. The speeds required for each fan are selected here. The function can be used with a kitchen fan or other device that requires additional supply air.

AIR VOLUME COMPENSATION		
SUPPLY AIR	MAX	OK?
EXTRACT AIR	MIN	

9.5 Idle mode

In this menu you can adjust the time it takes before the display enters idle mode.

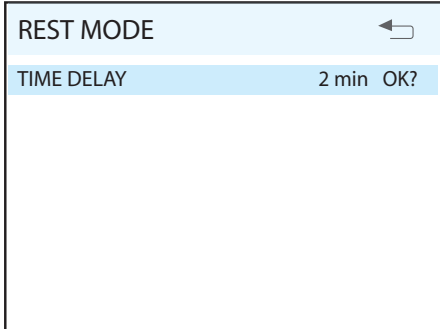

Sensors

The temperature sensors can be calibrated in this menu to be better coordinated with the real situation, and a pressure sensor is activated as a pressure guard instead of the integrated time control.

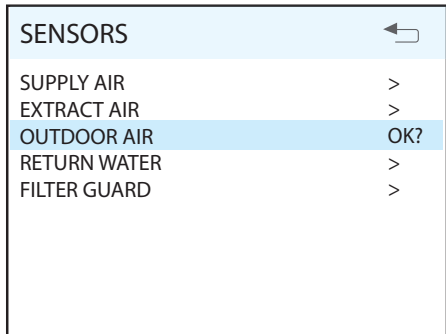

The menu screen is identical for all temperature sensors and they can be adjusted within an interval of 5 °C.

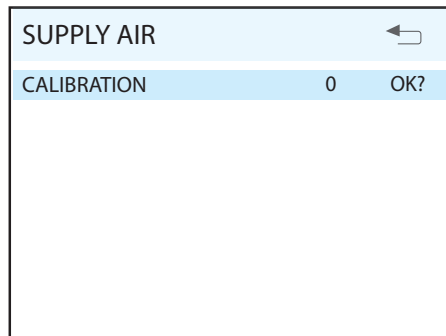

If the pressure guard is activated, an external sensor must be connected to the control card. The sensor replaces the integrated filter time control.

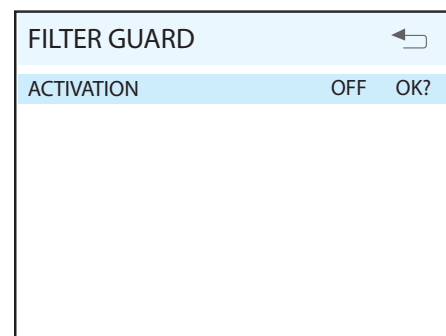

Fire/Smoke

This function requires an external sensor to be connected to the control card.

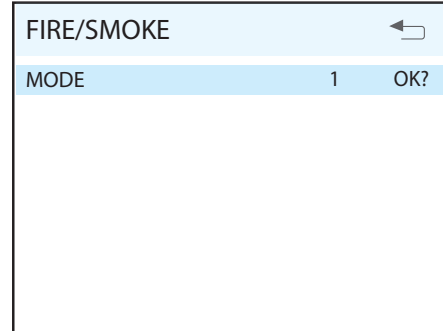

Mode	Supply air fan	Extract air fan
1	STOP	STOP
2	MAX	MAX
3	STOP	MAX
4	MAX	STOP

Communication

Proceed to the "HOME/AWAY" submenu. This function can be used to make the unit run on other operating settings using an external switch.

NB! The settings have no effect unless an external switch is connected.

The settings are entered for the AWAY selection. Speed and temperature can be selected, plus how long after activation the new setting should take effect.

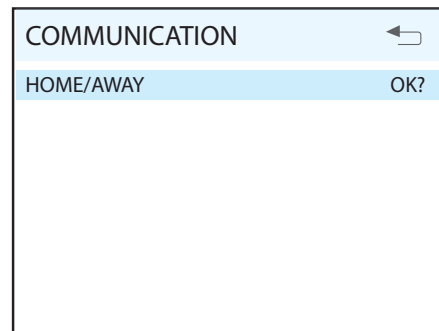

Standby mode

In this menu you can adjust the time it takes before the display enters idle mode.

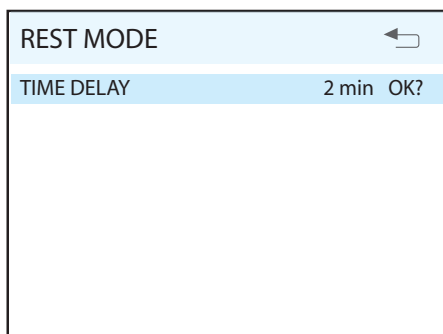

9.6 Operating time

This menu screen displays the ventilation unit's total operating time and how much time has passed since the last filter change.

OPERATIONS COUNTER	
OPERATING TIME	459.7 TIM
FILTER	459.7 TIM
STOP	0.0 TIM
MIN	123.0 TIM
NORMAL	161.4 TIM
MAX	178.0 TIM
ROTOR	0.4 TIM
HEATING ELEMENT	0.3 TIM

9.7 Service



Passwords are only revealed in consultation with Flexit's service department.

De-icing

The integrated de-icing function is not activated at the time of delivery of the ventilation unit. The function can be configured and activated in this menu screen.

Search path for menu selection:

MAIN MENU/SETTINGS/ADVANCED USER/SERVICE/DEFROSTING

DE-ICING	
DE-ICING	OFF OK?
START TEMPERATURE	-9°
PERIOD TIME	60 min
FREQUENCY	1/TIM
ROTOR SPEED	15
START FAN REDUCTION	-14°
PERIOD TIME	60 min
FREQUENCY	1/TIM
FAN SPEED	50%

De-icing

Activates/deactivates the function.

Start temperature

The start temperature for the defrosting function is set here.

The temperature in question is the outdoor temperature.

Period time

Period time for de-icing operation.

Frequency

Decides how many times the period shall be repeated per hour.

Rotor speed

When the start temperature has been reached, the speed of the drive motor of the rotating heat exchanger is reduced to the specified RPM.

Start fan reduction

As an additional safety function, the speed of the supply air fan can be reduced. This takes effect at the set outdoor temperature.

Period time

Period time for de-icing operation.

Frequency

Decides how many times the period shall be repeated per hour.

Fan speed

As an additional safety function, the speed of the supply air fan can be reduced. This takes effect at the set outdoor temperature.

De-icing - Parameters

Parameter	Default	Range	Unit
De-icing	OFF	OFF/ON	
Start temperature	-9	(-5)-(-45)	°C
Period time	60	1-60	min
Frequency	1	1-10	no./hour
Rotor speed	15	15-180	rpm
Fan reduction	-14	(-5)-(-45)	°C
Period time	60	1-60	min
Frequency	1	1-10	no./hour
Fan speed	50	20-100	%

9.8 Menu tree

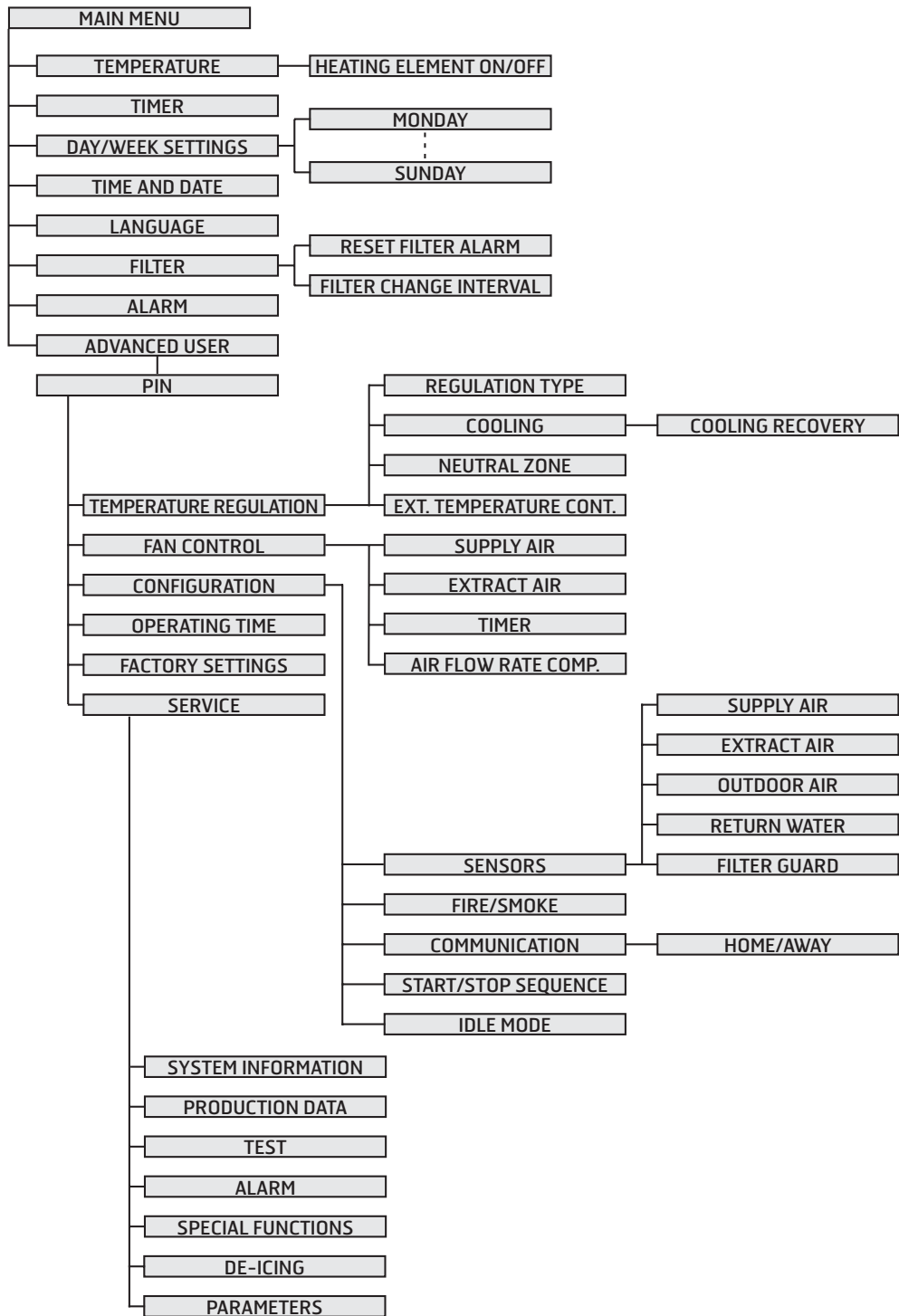

10 Cleaning and maintenance



Before opening the door: switch off the heat, let the fans continue for 3 minutes to remove hot air, unplug the unit and wait 2 minutes before opening the doors.

10.1 Changing the filters

The filters have a limited life, and to preserve a healthy indoor air quality it is important to change them when they are dirty.

How often the filters need to be changed depends on the degree of contamination of the air where they are installed. In general, the filters need to be changed at least once a year, preferably in the autumn (after the pollen season). In areas with a lot of dust and pollution, the filters should be changed in the spring and autumn.

Dirty filters can, among other things, lead to:

- Reduced performance of the unit
- The unit becoming dirty
- Humidity damage in the home
- Reduced indoor air quality

A filter subscription is recommended to ensure full benefit from the system. Both filters should always be changed.

To take out the filters:

1. Pull the filter drawer out as far as it will go. The drawer does not have to be removed completely.
2. The filter is now loose and can be removed.
3. Put a new filter in and push the drawer fully into place.

When changing the filter, check that the whole unit is working normally.

Use the following checklist:

- Check that the rotor is rotating. Turn the rotor in the direction of rotation as shown on the rotor cassette.
- If necessary, clean the rotor.
- Check that the fans are clean.

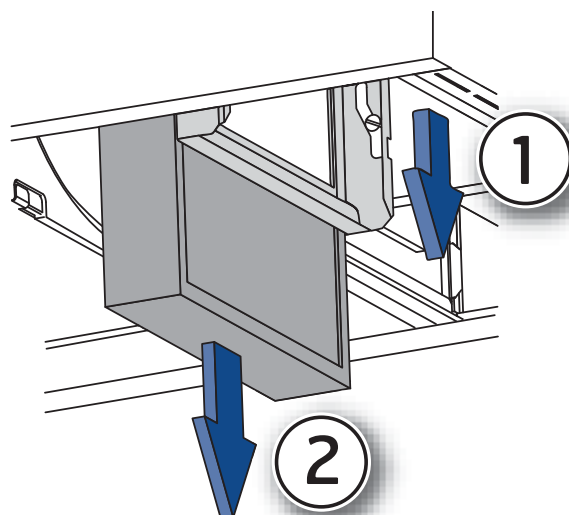

figur 2 Changing the filters



Check that the seal is intact before inserting the filter. Then push the filter drawer fully into place to prevent air leakage.



Make sure that the filter is not damaged during fitting. Use the filter's outer edge to push it in. A damaged filter reduces the output of the unit and the purity of the air.

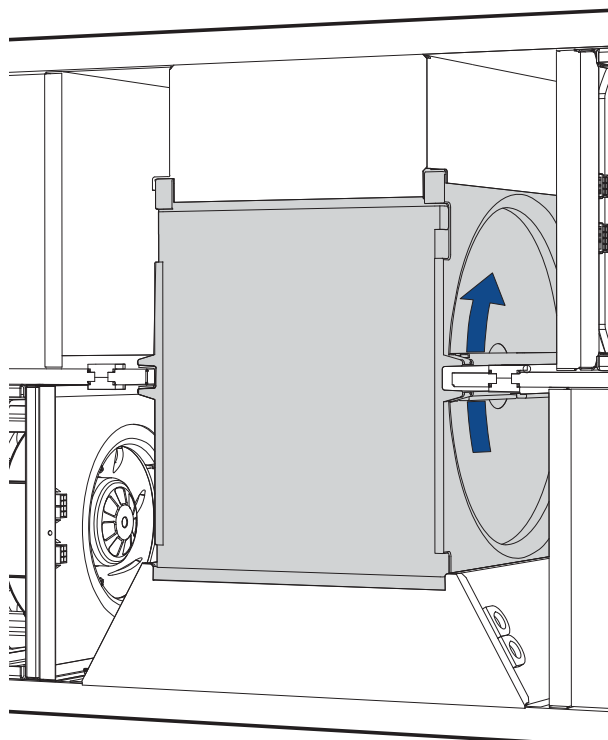

figur 3 Rotational direction of rotor

10.2 Cleaning the fans

The fans must be cleaned at least once a year. Clean the fan blades with a grease solvent on a cloth (e.g. methylated spirits) and compressed air if possible. NB Take care that the motor is not exposed to water.

To take out the fans:

1. Undo the screws on the electric cover and take the cover off.
2. Release both fan contacts
3. Release the wires to the fans, take the cable bushings along with you.
4. a) Extract the fan brackets (two per fan)

 **Note that the fans will fall out when the fan brackets are released.**

- b) Extract the fans, being careful not to damage the cable.

To put the fans back, follow the points in reverse order.

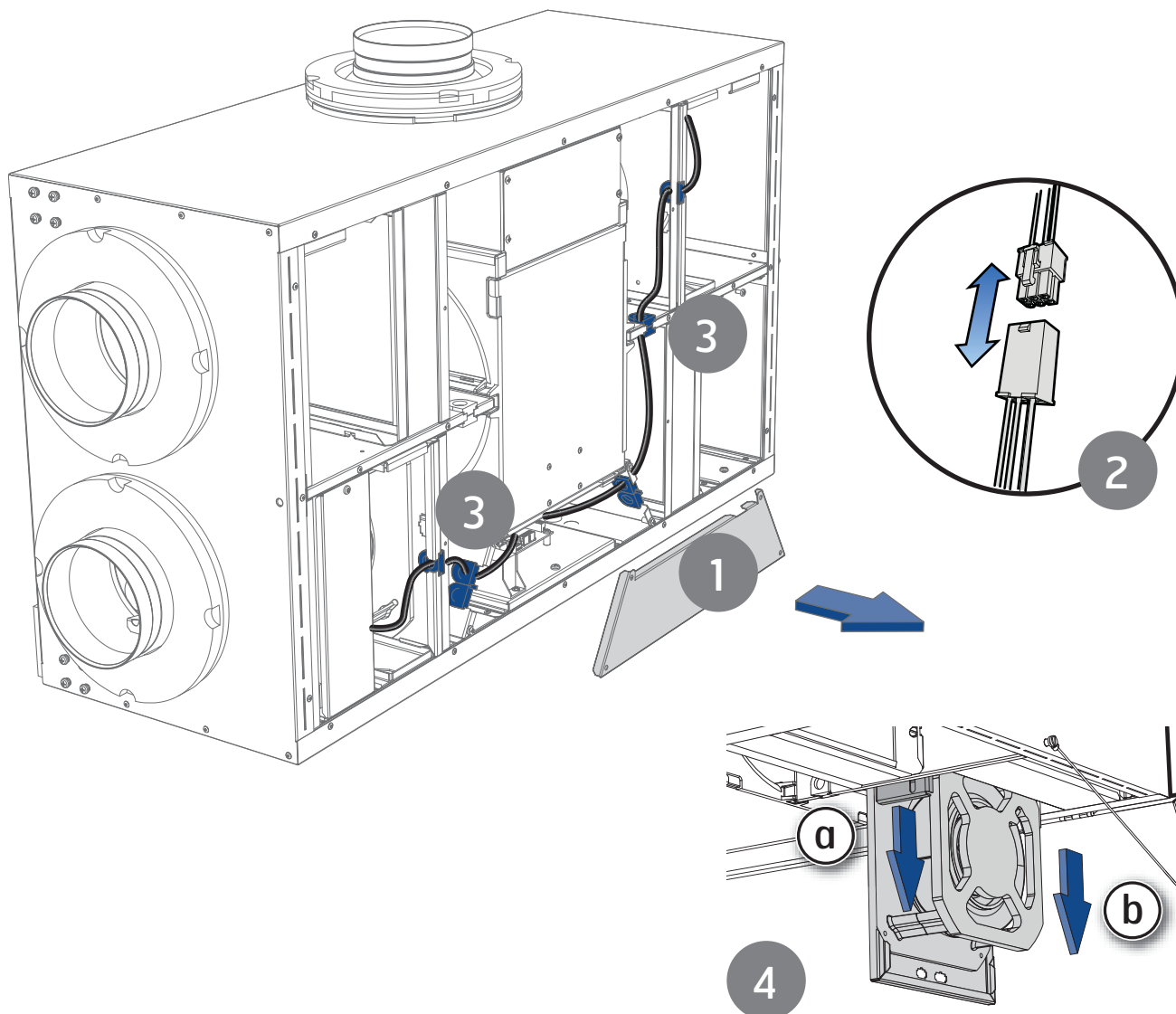

10.3 Changing the brush strips

The brush strips become worn over time. If they do not lie tightly against the rotary exchanger, it may be necessary to change them. Alternatively, they may be moved closer to the rotor, as the aluminium profile they are mounted in has two grooves.

Proceed as follows:

1. Undo the screws on the electric cover and take the cover off.
2. Draw out the electrical board
3. Disconnect the rotor's quick-release contact from the circuit board by pressing the release down and pulling the contact.



Note that the fans will fall out when the fan brackets are released.

4. Undo the screws on the electric cover and take the cover off.
5. Pull the rotor module straight out.

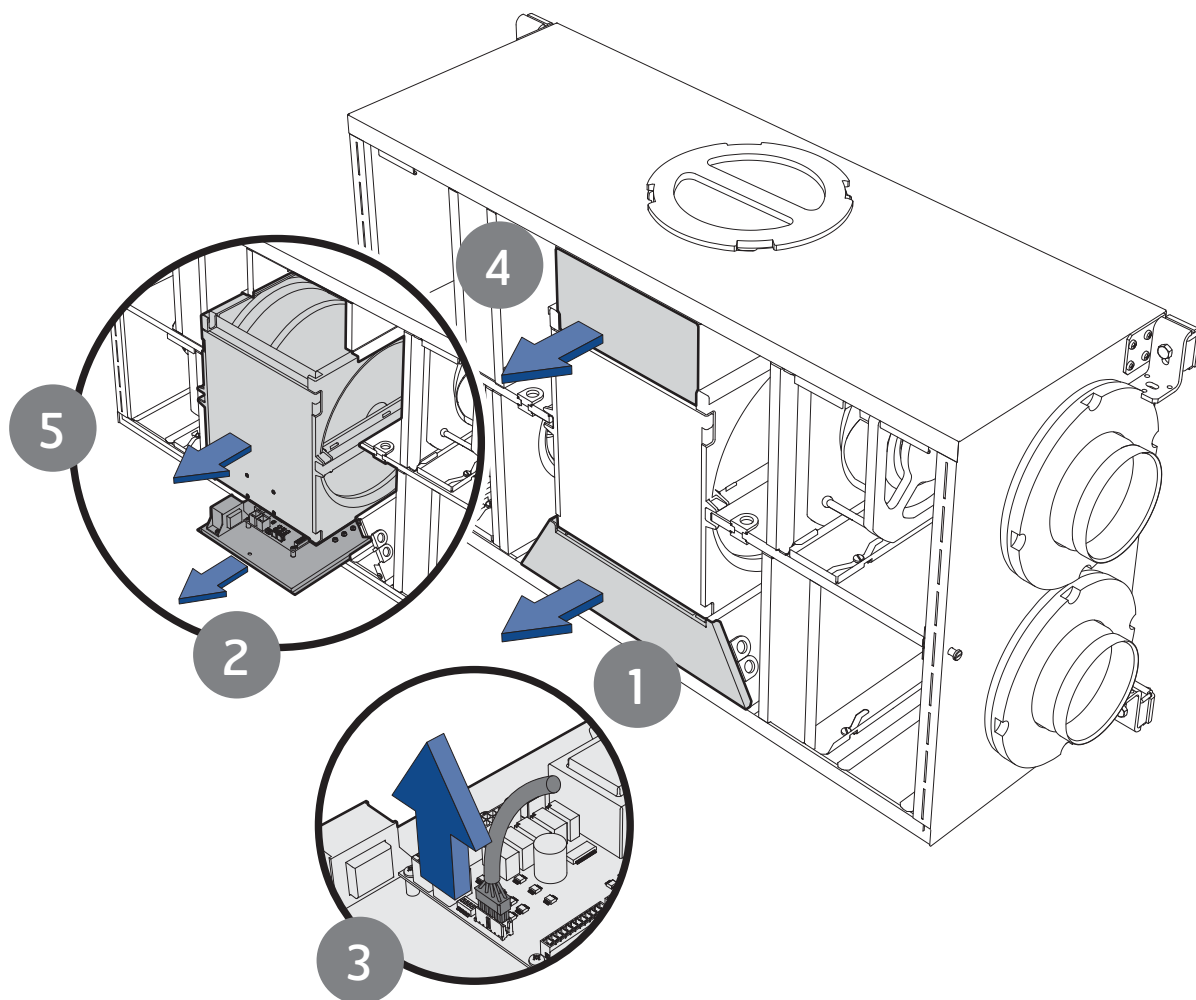

continued next page

6. Flip off the brush strip profiles with a screwdriver, etc. There are 4 brush strips on the rotor, 2 on each side.

Use a large screwdriver, so you can get a good contact without bending the profile. Start at one end and continue to the other.

7. Pull the brush strips out of the groove.
8. Move the brush strips down to level 2), or replace them with new ones if they are completely worn out.

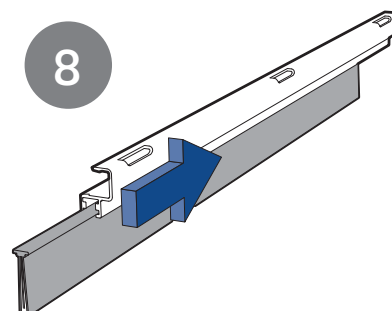
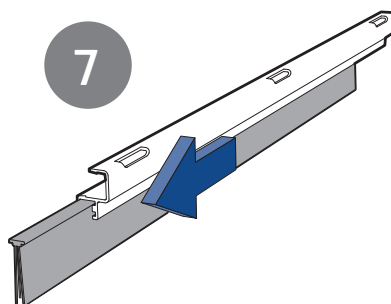
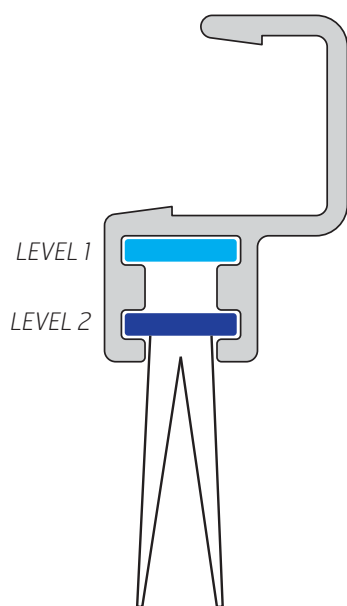
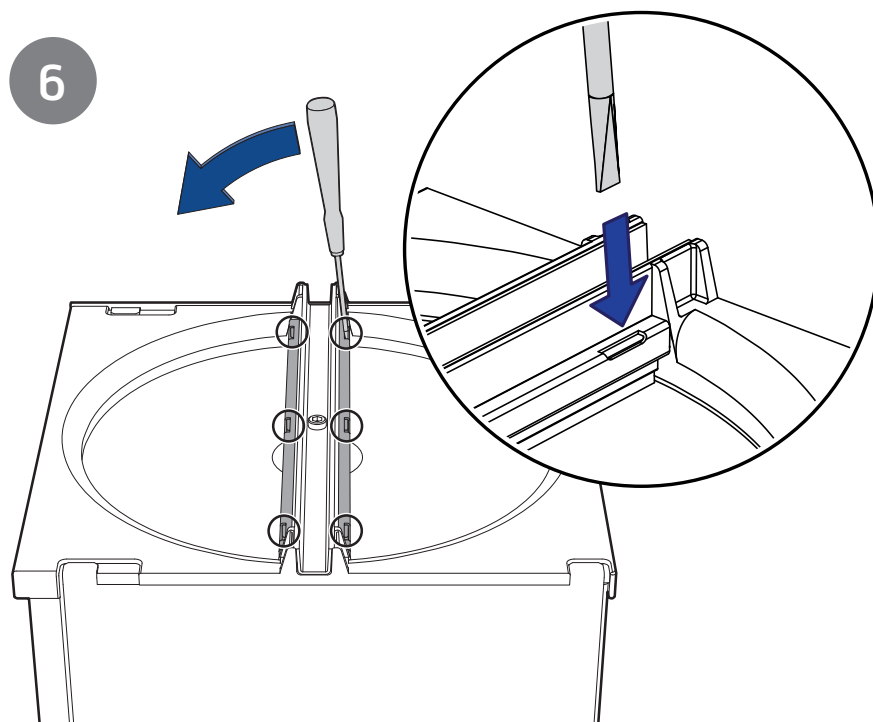

10.4 Cleaning the rotor

High impermeability filters are installed in the unit. It is not therefore usually necessary to clean the rotor. If, for various reasons, it should still be necessary, dust can be removed with a soft brush. Further cleaning is possible by removing the rotor, spraying it with a grease solvent and then blowing it clean from the opposite side. Distance approximately 60 mm and max. pressure 8 bar. Ensure that the motor is not exposed to water during cleaning. Ensure that all seals around the rotor are intact and tight. Ensure that there is no damage to the rotor belt, and that the rotor rotates freely.

10.5 External cleaning

Many kitchen surface cleaners contain chemicals that may damage the product's plastic components. Therefore use a soft cloth moistened with warm water and a neutral detergent to clean the outside of the product.



Do not use abrasive cleaners or scouring powder, as such products can damage the surfaces. Cleaners containing ammonia or citrus must not be used. Products that give stainless steel an anti-fingerprint coating must not be used either.

11 Maintenance table

Component	Action	Interval
Filter	Filters must be changed at least once a year. It is best to change them twice a year, before and after the pollen season. Check that the filter seal is completely airtight.	6-12 months
Fans	Fans must be cleaned at least once a year to maintain fan efficiency.	12 months
Rotary heat exchanger	Check that the surfaces are clean. Check that the sealing strips face in towards the rotary heat exchanger. Check that the rotor belt is intact and not too slack.	12 months
Cooker hood*	Wash the grease filter. Check that the damper is clean and closes fully.	2 weeks
Seals	Check that the seals on the door, under the filters, on the fan modules and on the rotor module are intact.	12 months
Valves	The supply air and extract air valves (for the bathroom, bedroom, laundry room, etc.) must be cleaned at least once a year.	12 months
Air intake	Check that no leaves and other items are caught in the grille. In periods of sea smoke during winter the air intake can freeze up. If necessary it must be scraped clean so that the air can pass through.	12 months
Roof cowl	If the unit has a roof cowl, this must be checked for leaves and the like. Also check that the drain slots are open.	12 months
Ducts	Check that the ducts are clean.	10 years
Brush strips	Check that the brush strips are intact and sit tightly against the rotor. If they are worn, they can be moved to the next groove in the profile so that they are closer to the rotor.	3 years
Interior of unit	A combination of a very low outside temperature and damp extract air can lead to the formation of ice. Normally this will not be a problem - when normal operating conditions return the ice crystals will be converted to steam and removed from the unit via the exhaust air. In the case of extreme cold over extended periods the unit should be checked for ice.	

*For units with extract air from the cooker hood connected to the unit.

12 Troubleshooting

Type of fault	Remedial action
Cold draughts	Check what supply temperature has been selected. See control panel.
	Check that the rotor is rotating.
	Check that heating comes on.
	New extract filter needed.
Fans not working	Check that power is connected to the unit.
	Check that the overheating thermostat has not cut out.
	Reset by pressing the button*. Must also be reset on the automatic panel.
Low air flow rate	Check what speed the unit is set to.
	Check that the filters are airtight.
	Check the intake grille.

*Reset button, see next page.

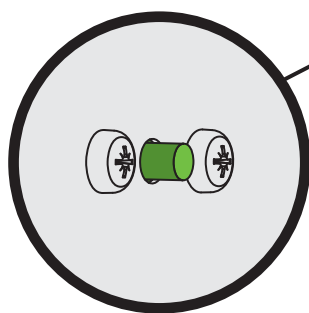
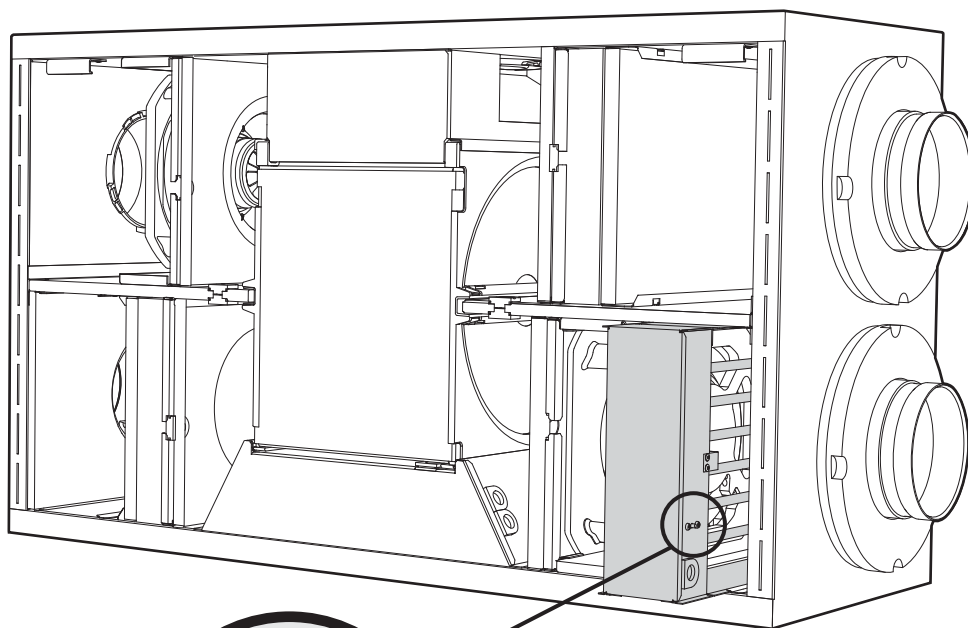

*Reset button.

The F10 thermostat must be reset manually by pressing the reset button.

13 CE Declaration of Conformity

This declaration confirms that the products meet the requirements in the following Council Directives and standards:

2014/30/EC Electromagnetic compatibility (EMC)
 2014/35/EC Low-voltage Directive (LVD)
 1253/2014 Ecodesign regulation
 1254/2014 Energy labelling regulation

Our products have been tested in accordance with parts of:

2006/42/EC Machine Directive (Safety)

Producer: FLEXIT AS, Televeien 15,
 1870 Ørje, Norway

Type: C2 R Ventilation unit

Compliance with valid versions of the following standards on the date on which the declaration of conformity was signed:

Safety standard	EN 60335-1 EN 60335-2-80
EMF standard:	EN 62233
EMC standard:	EN 55014-1 EN 55014-2 EN 61000-3-2 EN 61000-3-3

The product is CE-marked: 2015

FLEXIT AS 29.11.2016



Frank Petersen
 CEO

Warranty claims on this product are accepted in accordance with the applicable terms of sale, **provided that the product is correctly used and maintained**. Filters are consumables.



The symbol on the product shows that this product must not be treated as household waste. It must be taken to a reception station for recycling of electrical and electronic equipment. By ensuring correct disposal of the equipment, you will contribute to preventing negative consequences for the environment and health that incorrect handling may entail. For further information on recycling of this product, please contact your local authority, your refuse collection company or the company from which you purchased it.

Warranty claims due to incorrect or defective installation must be submitted to the installation company responsible. Warranty claims may be invalid if the system is used incorrectly or maintenance is grossly neglected.



Flexit AS, Televeien 15, N-1870 Ørje www.flexit.no