

94218E-06  
2016-02

# CVR 1000, CVR 2000, CVR 3000, CVR 4000



## **E** **Assembly instructions and user guide** Central vacuum cleaners

ART.NO.:  
04010  
04020  
04030  
04040



Congratulations on your choice of central vacuum cleaner! If you use your vacuum cleaner in accordance with these operating instructions, your machine will be a pleasure to use and an essential worktool in your home for many years to come.

Our products are under constant development and we, therefore, reserve the right to make any necessary alterations to the design of the machine. We also make reservations concerning any misprints that may arise.

Legislation governing consumer compensation claims apply to this product under current terms of sale - on the assumption that the product has been used correctly (for household use) and maintained in accordance with the instructions contained in this user guide. Dust bags are consumables.

Complaints caused by faulty or incorrect assembly should be made to the installation firm responsible. Entitlement to compensation may not apply through failure to use the machine correctly or gross negligence concerning the maintenance of the product.

## Contents

<b>Introduction</b> .....	<b>4</b>
<b>Symbols used for marking</b> .....	<b>4</b>
<b>Recycling</b> .....	<b>4</b>
<b>1 Important safety precautions</b> .....	<b>4</b>
1.1 Technical data .....	5
<b>2 Vacuum unit CVR 1000 assembly instructions</b> .....	<b>6</b>
2.1 Fitting the wall bracket.....	6
2.2 Locating the vacuum cleaner on the wall bracket.....	6
2.3 Connecting the machine .....	6
<b>3 Operating instructions CVR 1000</b> .....	<b>7</b>
3.1 Starting the machine .....	7
3.2 Servicing .....	7
<b>4 Filter and dust bags - CVR 1000</b> .....	<b>8</b>
4.1 Replacing the dust bag .....	8
4.2 Replacing / cleaning the filter .....	8
<b>5 Vacuum unit CVR 2000 / CVR 3000 / CVR 4000 assembly instructions</b> .....	<b>9</b>
5.1 Fitting the wall bracket .....	9
5.2 Locating the vacuum cleaner on the wall bracket .....	9
5.3 Connecting the machine .....	9
<b>6 Operating instructions CVR 2000 / CVR 3000 / CVR 4000</b> .....	<b>10</b>
6.1 Starting the machine .....	10
6.2 Servicing .....	10
6.3 CVR 4000 Display .....	11
<b>7 Filter and dust bags - CVR 2000 / CVR 3000 / CVR 4000</b> .....	<b>12</b>
7.1 Replacing the bag filter .....	12
7.2 Fitting the bag filter .....	12
7.3 Replacing the dust bag .....	12
7.4 Fitting the dust bag .....	12
<b>8 Electrical connection</b> .....	<b>13</b>
<b>9 Wireless communication - LED/LCD</b> .....	<b>14</b>
9.1 Transmitter/receiver .....	14
9.2 Wireless handle.....	14
<b>10 Troubleshooting</b> .....	<b>15</b>
10.1 Service/maintenance guide - CVR 1000 .....	16
10.2 Service/maintenance guide - CVR 2000 / CVR 3000 / CVR 4000 .....	16
<b>11 Dimensional drawings</b> .....	<b>17</b>
<b>12 Symbol explanation</b> .....	<b>18</b>
<b>13 CE Declaration of Conformity</b> .....	<b>19</b>

## Introduction

Symbols used for marking:



**ATTENTION!** When a text is marked with this symbol it means that damage to equipment or poor utilization may be the consequence if the instructions are not followed



**WARNING!** When a text is marked with this symbol it means that personal injury or serious damage to the equipment may be the consequence if the instructions are not followed



In this box you will find information about where you can read more about the same topic

## 1 Important safety instructions



**To reduce the risk of fire, electric shock or injury, read all safety precautions and warning text carefully before using the machine**

- This central vacuum cleaner is solely intended for dry vacuuming indoors.
- This central vacuum cleaner is not intended to be installed outdoors.
- Never vacuum without a filter installed.
- Do not vacuum up liquids. Do not use the machine in wet surroundings.
- Do not vacuum up embers or burning objects such as cigarettes, matchsticks, hot ash or flammable liquid or gas.
- Do not vacuum in areas where flammable liquids or gases may be present.
- Unplug the machine before changing the filter or bag and before doing any maintenance work.
- Always unplug the machine by pulling on the plug, not the power cord.
- The wall socket and plug must be positioned so that they are clearly visible.
- Do not vacuum up sharp objects such as broken glass or needles that could puncture the bag and damage the motor.

## Recycling



The symbol  on the product or on its packing indicates that this product may not be treated as household waste. Instead it shall be handed over to the applicable collection point for the recycling of electrical and electronic equipment. By ensuring this product is disposed of correctly, you will help prevent potential negative consequences for the environment and human health, which could otherwise be caused by inappropriate waste handling of this product. For more detailed information about recycling of this product, please contact your local city office, your household waste disposal service or the shop where you purchased the product..

- Be particularly careful not to pick up objects that could block the hose/pipe system, such as pencils, toy bricks and small plastic bags.
- Follow the operating instructions carefully. Servicing and repairs should only be carried out by an authorised workshop. Use only original parts and accessories as recommended by the supplier. Never attempt to modify the machine yourself.
- Do not use the central vacuum cleaner if the power cord is damaged. The central vacuum cleaner is fitted with a special type of power cord that must be replaced with a cord of the same type if it is damaged. A power cord of this type can be obtained from a service contact. To avoid any risk, this power cord should be replaced by a qualified expert.
- This appliance is not intended for use by young persons or infirm persons without supervision unless they have been adequately supervised by a responsible person to ensure that they can use the appliance safely.
- The central vacuum cleaner must not be used as a toy.
- The installation of the exhaust pipes must be done, so that no water or condensation will get into the installation system.



**The central vacuum cleaner must never be used to vacuum up contaminated dust or cement dust**

## 1.1 Technical data

Technical data, machine	CVR 1000	CVR 2000	CVR 3000	CVR 4000
Height	427 mm	800 mm	800 mm	800 mm
Width with handles	370 mm	370 mm	370 mm	370 mm
Length with bracket	400 mm	400 mm	400 mm	400 mm
Motor	1300 W	1550 W	1700 W	1700 W
Fuse	10 A	10 A	10 A	10 A
Weight	5 kg	6.5 kg	6.5 kg	6.5 kg
Sound output	66 dB	66 dB	66 dB	66 dB
Capacity of dust container	-	25 l	25 l	25 l
Capacity when using the bag	10 l	14 l	14 l	14 l
Max suction power motor	650 Airwatt	720 Airwatt	735 Airwatt	735 Airwatt
Max suction power*	460 W	490 W	510 W	510 W
Max air flow*	50 l/s	53 l/s	54 l/s	54 l/s
Max vacuum*	21 kPa	30 kPa	30 kPa	30 kPa
Radio remote control	X	X	X	X
Panel with operation status				X

\*Measured on the suction unit

Technical data, handle	LED	LCD
Radio frequency	433 MHz	
Function	On/off, power regulation 5 steps, LED indication of operation status	On/off, power regulation 5 steps, LCD indication of operation status
Lifetime of battery	3 years	3 years
Battery type, qty.	1,5V AAA, 2 pcs.	
Range of operation	Max 50 metres	

These appliances conform with EU Instructions 2004/108/EC, 2006/95/EC.

## 2 Vacuum unit CVR 1000 assembly instructions

### 2.1 Fitting the wall bracket

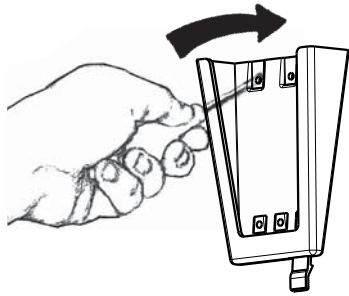

Fig. 1

Position the holder so that there is plenty of space above and below the place where the vacuum unit is to be located. Make sure there is a minimum of 500 mm free space above the container. Mark the positions for the four screw holes with a pen or similar. Then select appropriate screws and, if necessary, wall plugs for the type of wall surface to which the bracket is to be attached. Drill the four holes for the wall bracket. The diameter of the screw holes in the holder is 5 mm. Fit the wall bracket with the large opening pointing upwards, see Fig. 1. Tighten the screws so that the holder is held firmly in place (screws provided).

### 2.2 Locating the vacuum cleaner on the wall bracket

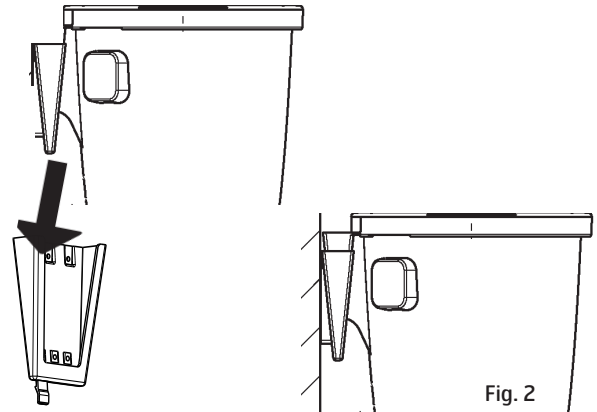

Fig. 2

Position the vacuum unit so that the wall bracket is directly above the wall bracket, see Fig. 2. Lower the machine down on to the wall bracket. Make sure the corresponding bracket on the machine is held firmly in place by the wall bracket.

### 2.3 Connecting the machine

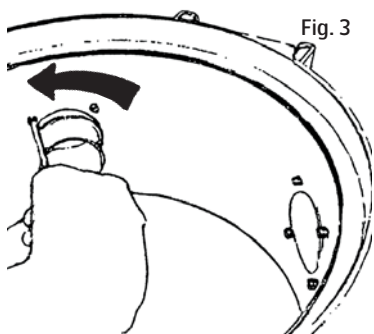

Fig. 3

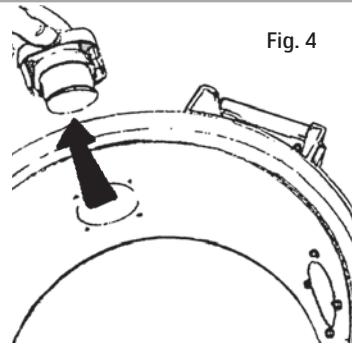

Fig. 4

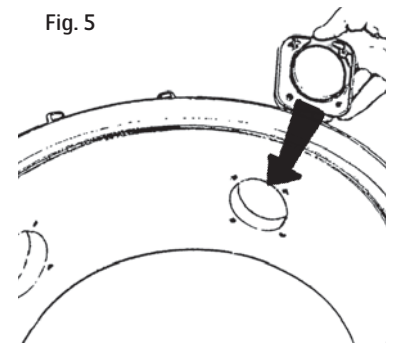

Fig. 5

The machine is connected with the suction pipe in the uppermost position and the exhaust pipe in the lower position. This connection should not be glued but can be taped when the unit is serviced at a later date. The suction pipe socket can be fitted to two different points depending on the direction in which you would like to install the pipe system.

To relocate the suction pipe socket, you need to do the following:

1. Release the suction pipe socket by unscrewing the four combination Torx screws with a Torx T20 or an ordinary screwdriver, Fig. 3.
2. Pull the socket out of the machine, see Fig. 4.
3. Loosen the plug blanking off the outlet to which you intend moving the suction pipe socket. Unscrew the four combination Torx screws. Remove the blanking plug from the machine.
4. Adapt (move) the suction pipe socket to the new outlet. NB! The socket is marked "Up".

Make sure the socket is fitted with "Up" uppermost. Fasten the socket by fitting and tightening the four screws, Fig. 5.

5. Fit the blanking plug to the outlet previously occupied by the suction pipe socket. Use the four screws to hold it in place. The exhaust pipe must be firmly attached to the wall to ensure its connection with the socket does not loosen. Remember that you will need to be able to turn the bent pipe in different directions to ensure a suitable pipe layout. Then connect up the exhaust pipe and muffler, Fig. 6. Fit the central vacuum cleaner so that the exhaust pipe is as short as possible, max. 5 metres. Take the surroundings into consideration when positioning the exhaust. For this reason, you should always fit a muffler.

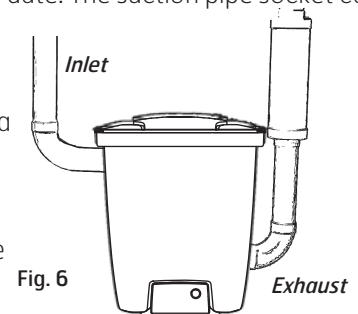

Fig. 6



For additional information concerning the assembly and installation of the pipe system and low-current lead, if any, please refer to the separate assembly instructions supplied with the pipe package.

### 3 Operating instructions CVR 1000

#### 3.1 Starting the machine

The central vacuum cleaner's power cable must be connected to a 230 volt mains socket. The appliance is double-insulated and does not need to be earthed.

##### Start/stop button

All models have a start/stop button on the front to start and stop the power unit, Fig. 7. The start/stop button can also be used when/if you want to use a Flexit utility inlet to vacuum direct from the machine (if you do not have a Flexit hose with remote control) or for testing and demos.

Fig. 7

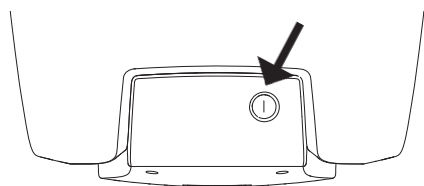

##### Wireless communication LED/LCD

The machine is controlled wirelessly from the hose handle of the vacuum cleaner. In this case you do not have to mount a low voltage cable between the vacuum socket and the machine.



See description in section 9.

Fig. 8

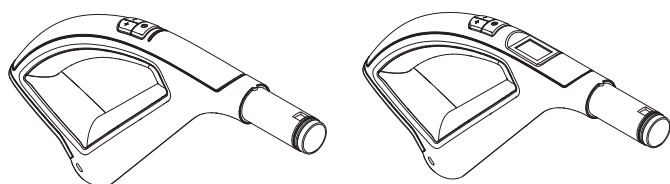

LED

LCD

##### On/off hose

Handle on hose with on/off button starting and stopping the vacuum cleaner.

##### Manual hose

The vacuum cleaner starts and stops automatically when the vacuum hose is connected to a vacuum socket. The metal ring on the end of the hose closes the control circuit and the vacuum cleaner starts up. When the hose is removed from the vacuum socket, the vacuum cleaner stops.



**Requires a low voltage cable between the vacuum socket and the machine**

##### Dustpan by the floor

Dustpan for mounting in a plinth under a cabinet will start and stop the vacuum cleaner when opened and closed.



**Requires a low voltage cable between the dustpan and the vacuum cleaner**

#### 3.2 Servicing



**Always unplug the power cord before doing any service work!**

If suction is poor, it indicates that the flow of air through the machine is restricted. This may be due to the following:

- The dust bag is full and should be replaced.
- The filter is clogged and should be cleaned.

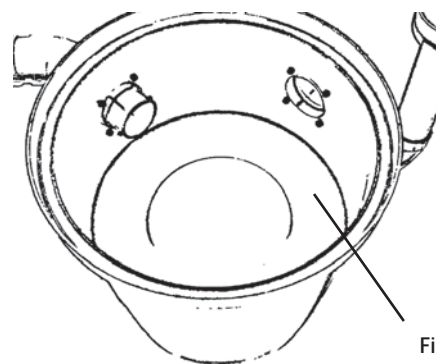

Fig. 9

Filter

##### Thermal cutout

The vacuum cleaner has a thermal cut-out that trips if the vacuum cleaner becomes overheated.

If this happens - unplug the main power cord to reset the vacuum cleaner. Wait 5-10 minutes to allow the machine to cool down. The vacuum cleaner should now start again. If the cut-out trips again, you need to get a service firm to remedy the fault.



**While you are waiting, check the hose, dust bag and filter to be sure that nothing is blocking the flow of air through the machine**

## 4 Filter and dust bags - CVR 1000

### 4.1 Replacing the dust bag

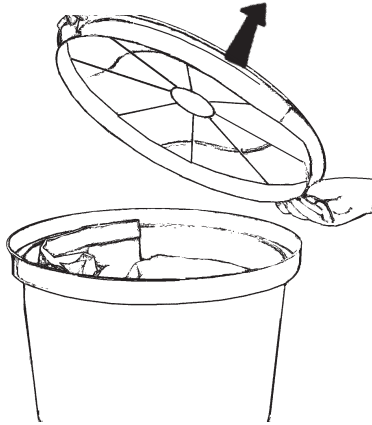

Fig. 10

The central vacuum cleaner is fitted with a dust bag as standard.



**Never vacuum without a dust bag installed**

Grasp the edge of the lid and pull upwards to open it, Fig. 10.

**Replacing the dust bag:** Remove the old dust bag by turning the cardboard stiffener to the right or left so that the raised part of the inlet is in line with the opening in the card. Now slide the bag off the bag nozzle.

**Fit the new dust bag as follows:** Push the opening in the cardboard over the elevation on the inlet and pull on the new bag. Turn the cardboard to lock the bag in place. The cardboard stiffener locks the bag in place when you twist it as shown in Fig. 11.



**NB! Turn the edges of the dust bag down into the container. This is to avoid damaging the bag with the lid**

Fig. 11

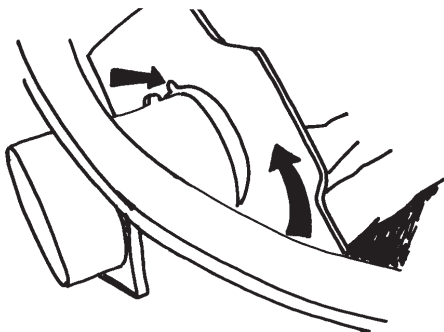

The opening in the card must line up and slide over the elevation on the inlet before you twist the cardboard stiffener to lock it.

### 4.2 Replacing / cleaning of filter

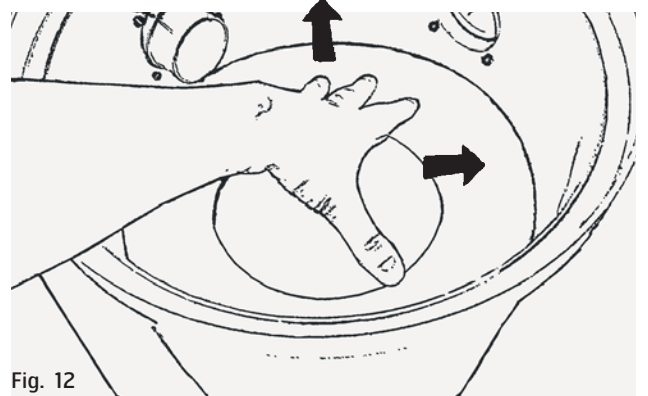

Fig. 12



**Never use the central vacuum cleaner without a filter installed**

Open the lid and take out the dust bag as described earlier. The filter sits at the bottom of the container around the motor housing.

Pull the filter out of the container, Fig. 12. The filter can be cleaned by shaking it or washing it in water. If you wash the filter, you must let it dry completely before refitting it.

Take the cleaned/new filter and place it in the bottom of the container. Press the outer edge of the filter down against the sides of the container so that the filter bulges up slightly. Then push the filter down into place. Make sure the filter is packed in tightly against the motor housing, Fig. 13. Reinstall the dust bag and replace the lid. Check that the lid is firmly secured.

Fig. 13

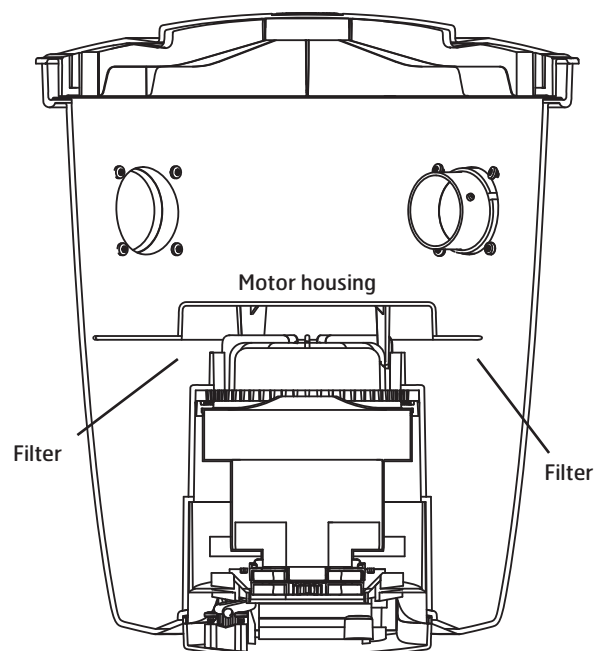



## 5 Assembly instructions CVR 2000 / CVR 3000 / CVR 4000

### 5.1 Fitting the wall bracket

Plan the positioning of the wall bracket so that there is plenty of space above and below the area where the vacuum unit is to be located. Make sure there is a minimum of 200 mm free space below the dust container.

Mark the positions for all four screw holes with a pen or similar. The diameter of the holes in the holder is 5 mm. Select screws and, if necessary, wall plugs suitable for the type of wall concerned. Drill the four screw holes. Fit the wall bracket with the large opening pointing downwards, see Fig. 14. Then screw the holder firmly into place.

Fig. 14

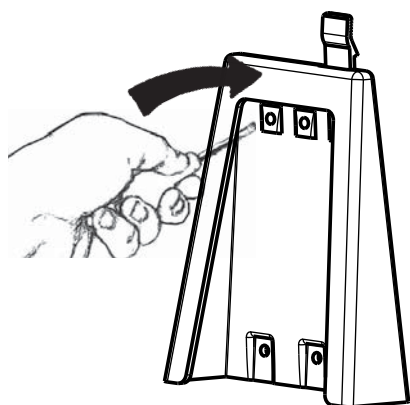

### 5.2 Locating the vacuum cleaner on the wall bracket

To facilitate the procedure, first remove the dust container. Free the container by pulling both handles up and then outwards. Then remove the container from the machine. To mount the vacuum cleaner/motor chassis to the wall bracket - just lower the chassis downwards so that the locking device of the bracket will pass through the slot of the chassis, Fig. 15. Make sure the corresponding bracket on the machine is held firmly in place by the wall bracket.

When removing the vacuum cleaner from the wall bracket - push the locking device towards you so it will release the bracket and then lift the vacuum cleaner up from the bracket.

Fig. 15

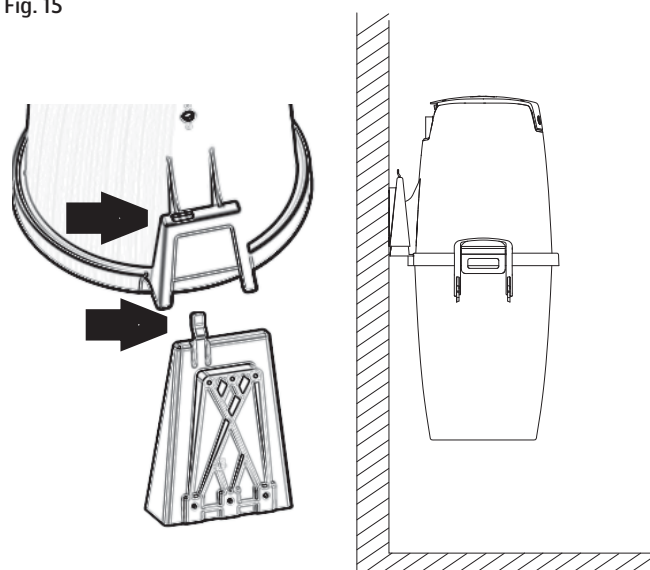

### 5.3 Connecting the machine

Fig. 16

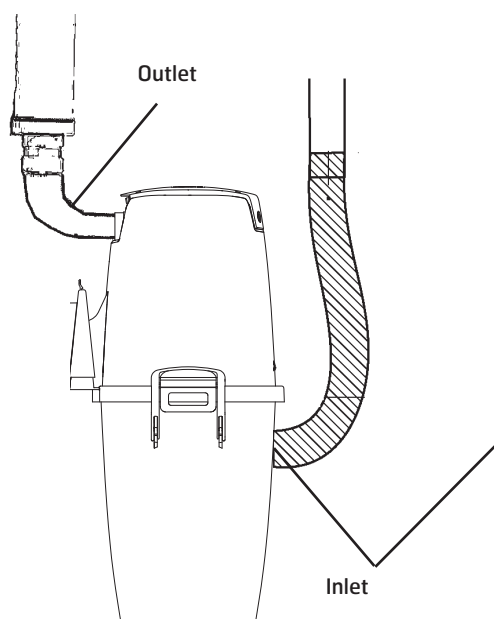

**Warning:** If the pipe system in your house has another diameter than a standard Flexit pipe system, transition pieces can be bought in a shop. Outer diameter of Flexit pipe system is Ø51 mm

The machine is connected with the flexible suction hose in the lower position and the exhaust pipe uppermost, Fig 16. The flexible hose is connected to the dust inlet at the container of the cleaner. Push the hose in to the inlet at the cleaner until the hose locks.

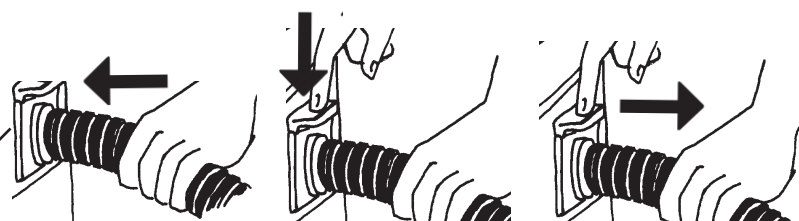

Push the hose in to the inlet at the cleaner until the hose locks. Press the button on the hose inlet downwards in order to remove the suction hose.

The attached rubber sleeve is used for tightening/loosening the joint between the pipe system and the flexible vacuum hose. Feed half the length of the sleeve into the vacuum hose and fold the other half over. Then feed 5-10 mm of the vacuum hose into the pipe system and fold the sleeve back so that it envelopes the tail pipe.

The flexible suction hose acts as an adapter connecting the vacuum unit with the pipe system.

Position the central vacuum cleaner so that the exhaust pipe can be kept as short as possible, maximum. 5 metres. Take the surroundings into consideration when positioning the exhaust. For this reason, you should always fit a muffler.

**⚠ NB! These connections must not be glued in case the unit is handed in for service.**



For additional information concerning the assembly and installation of the pipe system and low-current lead, please refer to the separate assembly instructions supplied with the pipe package.

## 6 Operating instructions - CVR 2000 / CVR 3000 / CVR 4000

### 6.1 Starting the machine

The central vacuum cleaner's power cable must be connected to a 230 volt mains socket. The appliance is double-insulated and does not need to be earthed.

#### Start/stop button

All models have a start/stop button on the front to start and stop the power unit, Fig. 17. The start/stop button can also be used when/if you want to use a Flexit utility inlet to vacuum direct from the machine (if you do not have a Flexit hose with remote control) or for testing and demos.

Fig. 17

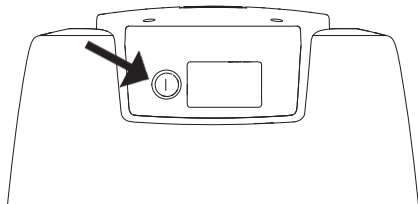

#### Wireless communication LED/LCD

The machine is controlled wirelessly from the hose handle of the vacuum cleaner. In this case you do not have to mount a low voltage cable between the vacuum socket and the machine.



See description in section 9.

Fig. 18

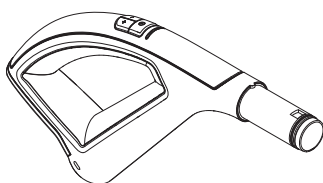

LED

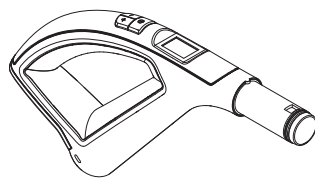

LCD

#### On/off hose

Handle on hose with on/off button starting and stopping the vacuum cleaner.

#### Manual hose

The vacuum cleaner starts and stops automatically. When the vacuum hose is connected to a vacuum socket, a metal ring on the end of the hose closes the control circuit and the vacuum cleaner starts up. Fig. 19. When the hose is removed from the vacuum socket, the vacuum cleaner stops.



**Requires a low voltage cable between the vacuum socket and the machine**

#### Dustpan by the floor

Dustpan for mounting in a plinth under a cabinet will start and stop the vacuum cleaner when opened and closed.



**Requires a low voltage cable between the dustpan and the vacuum cleaner**

### 6.2 Service



**Always unplug the power cable before doing any service work!**

If suction is poor, it indicates that the flow of air through the machine is restricted. This may be due to the following:

- The dust bag is full and should be replaced.
- The filter is clogged and should be cleaned of dust.

#### Thermal protector

The vacuum cleaner has a thermal cut-out that trips if the vacuum cleaner becomes overheated.

If this happens - unplug the main power cord to reset the vacuum cleaner. Wait 5-10 minutes to allow the machine to cool down. The vacuum cleaner should now start again. If the cut-out trips again, you need to get a service firm to remedy the fault.

On CVR 4000 which has a display, the symbol for overheating will flash.



**While you are waiting, check the hose, dust bag and filter to be sure that nothing is blocking the flow of air through the machine**

### 6.3 CVR 4000 Display

CVR 4000 has a display giving information about the machine, Fig. 19.

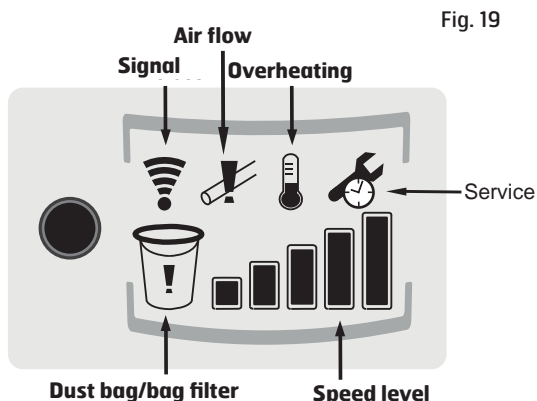

Fig. 19

#### Speed level

Shows at which of the five speed levels the machine is operating.



#### Indicator for dust bag/bag filter

When the dust bag/filter symbol starts flashing during operation, the cleaner tells you that it is almost time to clean the bag filter and replace the dust bag/empty the container. When it is time to do so, symbol will be lit continuously. The dust bag/filter symbol will be lightened after every 20 operation hours of the cleaner at the latest.



As an extra precaution, the dust bag/filter symbol will also come on permanently after every 20 hours of operation. When this happens, check the bag filter and dust bag/container in the same way. The warning can be reset when the machine is off by holding the machine's on/off button (not the handle) in for approx. 3 seconds until the machine stops.



Cleaning/replacement is described in Section 7

#### Reduced airflow indicator - lit

The reduced airflow symbol on the display indicates that the airflow through the vacuum cleaner is reduced. After 30 seconds of operation with reduced airflow, the vacuum motor will be shot down in order to prevent damage to the motor. If the reduced airflow symbol is lit and the motor has been shot down, do like this: Check the bag filter and dust bag (see Sections 7.1, 7.2, 7.3 and 7.4) to see if anything is blocking the airflow. Also check that nothing is blocking suction hose and/or vacuum sockets. Remove the material causing the reduced airflow symbol to indicate.



#### Service indicator

When the service symbol starts flashing, the motor will run for one more hour before it stops/will not start. The purpose of the service symbol is to inform you that it is time to order service of the cleaner. When the



symbol is continuously lit, the run time counter in the cleaner has counted that the allowed amount of run time has passed. You must now contact an authorised service workshop and let them perform a service of the cleaner and to reset the run time counter.

#### Overheat indicator - flashing

The overheat symbol indicates that the cleaner has become overheated. The cleaner stops automatically. Unplug the main power cord to reset the vacuum cleaner and wait 5-10 minutes to allow the machine to cool down. While you are waiting, check the bag filter, container/dust bag, suction hose and vacuum sockets to be sure that nothing is blocking the flow of air through the machine.



#### Signal indicator - flashing

When the symbol is flashing, the hose handle is out of range and there is no connection to the cleaner. The cleaner will automatically stop after 30 min. if the hose handle or the cleaner has not been activated.



## 7 Filter and dust bags - CVR 2000 / CVR 3000 / CVR 4000

### 7.1 Replacing the filter

A bag filter must always be installed in the dust container. Clean the filter in the following way:

1. Release the two handles clamping the dust container. The handles are easily unlocked by lifting up the handles until they come to a stop. When you pull the handles outwards away from the cleaner, the container is released. Fig. 20.

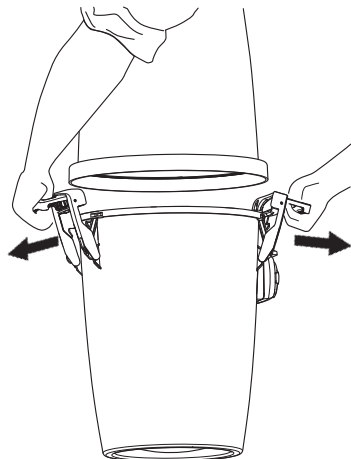

Fig. 20

2. Do not remove the filter from the container. Instead, give the filter a light shaking inside the container to loosen dust from the filter allowing it to fall into the container. This is done by grasping the strap on the filter and quickly move the filter up and down as shown in Fig. 21.

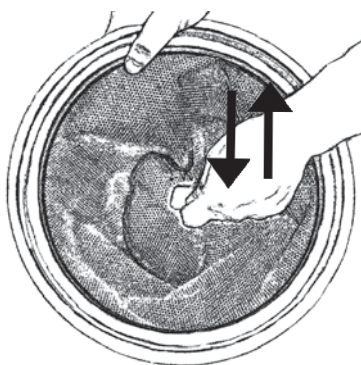

Fig. 21

3. Lift out the bag filter. If a dust bag is being used - remove the dust bag. Then empty the container of any remaining dust in a suitable place.

### 7.2 Fitting the bag filter

Replace the bag filter in the machine as follows:

1. Replace the cleaned/shaken bag filter in the container. Make sure the filter support fits into the inner edge of the dust container properly. Check that the filter is fitted the right way up - the cloth handle on the filter should be visible.
2. Then replace the dust container with the bag filter in the suction unit.
3. Attach the container on the suction unit by lifting the container back in place and pushing the handles back in over the edge

of the cleaner till you hear a click. Push down the handles and ensure that the vacuum unit and dust container are fitted together properly.

### 7.3 Replacing the dust bag

The machine is supplied with a dust bag. Replace the dust bag in the following way:

1. Release the two handles clamped on to the dust container. The handles are easily unlocked by lifting up the handles until they come to a stop. When you pull the handles outwards away from the cleaner, the container is released. Fig. 20.
2. Lift off the container.
3. Shake the dust from the bag filter. It may be advantageous for the filter to be installed in the container in such a way that dust in the filter can be shaken down into the dust container.
4. Lift out the bag filter.
5. Remove the dust bag by taking hold of the cardboard stiffener and carefully pulling out the card and bag from the container, Fig. 22. Fold down the perforated part of the cardboard towards the opening of the bag in order to prevent the bag contents to leak out.

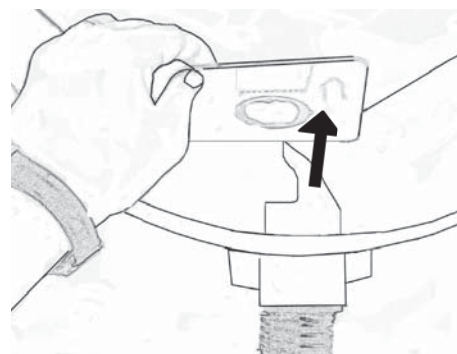

Fig. 22

6. Empty the container of dust.

### 7.4 Fitting the dust bag

Replace the dust bag as follows:

1. Fit the dust bag's card with a hole into the bag holder, Fig. 23.

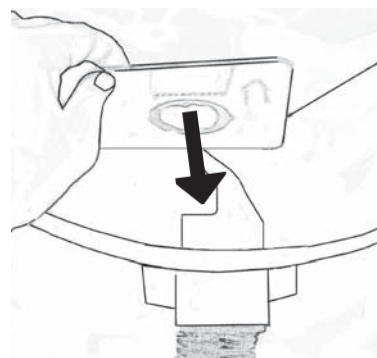



Fig. 23

2. Replace the cleaned/shaken bag filter in the container. Make sure the filter support fits into the inner edge of the dust container properly. Check that the filter is fitted the right way up - the cloth handle on the filter should be visible.
3. Replace the dust container on the vacuum unit. Close the container on the vacuum unit by applying inward pressure to the two handles to ensure the vacuum unit and dust

container are fitted together properly.

CVR 2000 / CVR 3000 / CVR 4000 can be run with or without the installation of a dust bag - the choice is yours.

 **These products must though always be operated with the bag filter fitted in the cleaner**

## 8 Electrical connection

### Connection of pilot current

The pilot current outlet (low voltage) is connected to a low voltage lead running the length of the pipes. Both ends of the low voltage lead are connected to the connection panel on the vacuum unit. One lead to each outlet, see illustration below.

#### CVR 1000

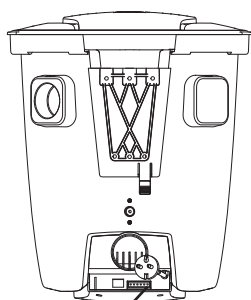

#### CVR 1000

The connection panel is located in the bottom of the vacuum unit

#### CVR 2000, CVR 3000, CVR 4000

The connection panel is located in the top of the vacuum unit

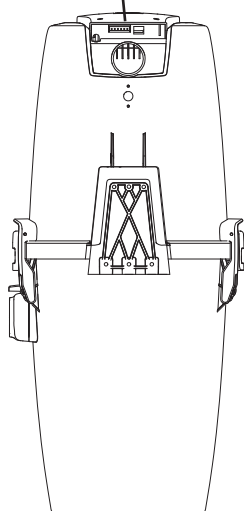

### Forcing signal ventilation unit

Connection to units capable of receiving pilot signal for forcing of supply air.

When the vacuum cleaner starts, the ventilation unit will increase the volume of air during vacuuming. This to compensate for the air the vacuum cleaner draws out of your house. When the vacuum cleaner is switched off, the ventilation unit returns to original speed.

To be connected with a low voltage lead between the vacuum cleaner and the ventilation unit.

 **Connection to ventilation unit; see operating instructions of the unit**

Connect forcing signal to this outlet.

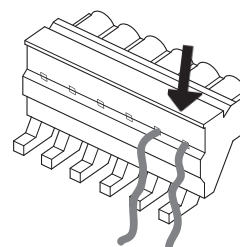

### Connection panel for low voltage lead

The low voltage leads are connected by snap lockings. Insert leads in the snap lockings (one in each point). Secure the low voltage cables by pulling the snap lockings at the connector upwards.

Secure the low voltage cables at the connector

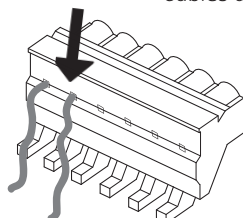

## 9 Wireless communication - LED/LCD

### 9.1 Transmitter/receiver

Before you mount the transceiver box to the wall you should always test if you have a signal between the transceiver box and the hose handle in your entire home. Connect the box to the cleaner and turn the cleaner on and off using the hose handle from different places in your home.

#### Connecting the transmitter/receiver

To be able to use the wireless Flexit hose handles, you must first connect the transmitter/receiver to the cleaner. This is done by using the 2 meter network cable (RJ45) that comes with the transmitter/receiver. Connect the cable to the transmitter/receiver and the right socket in the back of the cleaner.

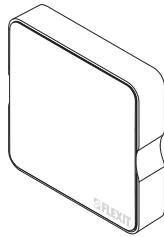

#### Installing the transmitter/receiver

Mount the transmitter/receiver on the wall minimum 1 meter (if possible) away from the cleaner for best signal between the transmitter/receiver and the hose handle. The transmitter/receiver can be moved to different places in your home for a better range by using an up to 30 meter network cable. Cables can often be bought in your local Electronics store.

#### The first transmission

The hose handle and the cleaner needs to have a first communication before starting the cleaner. This is also valid if the hose handle has been replaced (spare part) or if you want to connect an extra hose. Do like this before starting your wireless cleaner:

1. Unplug the main cord.
2. Plug in the cord again, and then push the on/off button at the hose handle for approximately 10 seconds. This must be done within 60 seconds after the cleaner has been plugged in
3. The handle and the cleaner do now communicate.

### 9.2 Wireless hose handle

#### Instructions for use

The on-off function and power regulation is controlled by radio technology.

#### Start and stop

**Start:** One push at the switch will start the cleaner.

**Stop:** One push at the switch will stop the cleaner.

The power regulation can be adjusted in 5 steps. You switch between the different steps by pressing the (+) or (-) buttons at the hose handle.

#### LED

The LED-indicator is placed above the on/off button and will be activated with different lights depending on the actions

that are taken: The lamp is activated at start or stop actions or when the power regulation is adjusted.

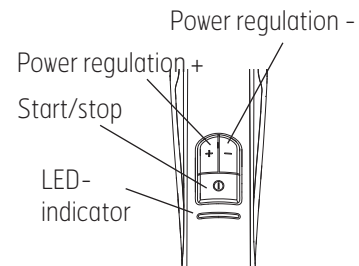

The lamp flashes a warning light that indicates that the bag filter is clogged or that the container/dust bag is full and needs cleaning/replacement (see Section 7).

As an extra precaution, the lamp will also flash after every 20 hours of operation. When this happens, check the bag filter and dust bag/container in the same way. The warning can be reset when the machine is off by holding the machine's on/off button (not the handle) in for approx. 3 seconds until the machine stops.

#### LCD info center display

The display is placed above the on/off button and will show different symbols depending of the status of the cleaner.



**Speed level:** Bars shows the actual speed level.



**Low Battery:** The batteries are below 5 %. Replace batteries. See Battery, this section.



**Signal:** Signal flashes if the hose handle is out of reach. No contact to the vacuum cleaner.



**Bag/filter:** The container symbol flashes or glows regularly. Check bag filter and dust bag. See section 6.3, Indicator for dust bag / bag filter.



As an extra precaution, the container symbol will also come on permanently after every 20 hours of operation. When this happens, check the bag filter and dust bag/container in the same way. The warning can be reset when the machine is off by holding the machine's on/off button (not the handle) in for approx. 3 seconds until the machine stops.



**Air flow blocked:** When the service and the container symbol glows simultaneously, it indicates that the air flow through the vacuum cleaner is reduced. See section 6.3, Reduced airflow indicator.

**Service warning:** Warning that it is almost time to order service or that the allowed working time has been reached. See section 6.3 Service indicator.



**Overheating:** Flashing symbol indicates that the vacuum cleaner is overheated. The vacuum cleaner will stop automatically. See section 6.3 Overheat indicator.



### Battery

The lifetime of the enclosed batteries in the bent end is approximately three (3) years. If the battery capacity is too low, the cleaner will then be shut off. If the cleaner would not start or the power regulation via the hose handle does not work, you must replace the batteries at the hose handle. Replace to battery type 1.5V AAA. For more information and trouble shooting see Section 10 in this instruction for use.



**WARNING!**  
**Do not pull out the suction hose from the cleaner while the cleaner is still running as it will cause too little airflow through the cleaner.**  
**The machine has a safety shut off function and a thermal protector which will stop the machine but this will cause an unnecessary abrasion on the motor**

### How to replace the batteries in the hose handle

1. Open the lid of the battery holder by sliding the lid towards the front of the hose handle.
2. Replace the used batteries with two new ones, type 1.5V AAA. Make sure the polarity of the batteries is placed correct at the bracket.
3. Slide the battery lid back until you hear a click.



## 10 Troubleshooting

**All work involving the 240 volt mains electricity supply must be carried out by a qualified electrical contractor**

### The vacuum cleaner will not start Thermal protector

The vacuum cleaner has a thermal cut-out that trips if the vacuum cleaner becomes overheated.

If this happens - unplug the main power cord to reset the vacuum cleaner. Wait 5-10 minutes to allow the machine to cool down. While you are waiting, check the bag filter, container/dust bag, suction hose and vacuum socket to be sure that nothing is blocking the flow of air through the machine. The vacuum cleaner should now start again. If the cut-out trips again, you need to get a service firm to remedy the fault.

On CVR 4000 the symbol for overheating will show in the display of the vacuum cleaner.

### Other troubleshootings

- Are you using the correct hose? Only the original hoses fit correctly.
- Does the vacuum cleaner start when you try a different vacuum socket? If so, there is a fault in the electrical connection to the first socket. Unscrew the socket and

check the connection at the back.

- Is the power supply connected to the vacuum unit?
- Is there power at the socket?
- Is the low-voltage lead connected to the vacuum unit?
- The batteries to the wireless hose handle may have been discharged. Replace the batteries with new ones, type 1.5V AAA.

### The vacuum cleaner will not stop

- Has a metal object become lodged in one of the vacuum sockets causing the pins to become fused?

### Poor suction power

- Are all the vacuum sockets closed properly?
- Has something become jammed in one of the vacuum sockets?
- Is the container lid closed properly?
- Is the gasket between the container and the lid in place?
- Is it damaged?
- Is the pipe system blocked?
- Is the dust bag full or clogged?
- Is filter clogged?

### CVR 4000 Display

The CVR 4000 model has a display giving information about the machine, Fig. 19.

**10.1 Service/maintenance - CVR 1000**



**NB! Never vacuum without a filter and a dust bag installed**



Product	How often?	Why?	How?
<b>Dust bag</b>	Should be replaced before it becomes completely full, depending on use but normally 2-4 times a year.	Poor suction and danger of creating a blockage in the pipe system.	Grasp the edge of the lid and open it by pulling upwards. Remove the old dust bag by turning the cardboard stiffener to the right or left so that the elevation on the nozzle penetrates the opening in the cardboard. Now slide the bag off the inlet. Push the opening in the cardboard over the elevation on the inlet and pull on the new bag. Twist the cardboard to lock the bag in place. NB! The opening in the card must be adjusted and pushed past the elevation on the inlet before the cardboard can be locked into place with a twisting action. <b>Note: Never vacuum without a dust bag installed.</b>
<b>Filter in bottom</b>	Should be checked when changing the bag.	Poor suction can result. Dust can find its way into the motor.	Remove the dust bag as described above. Remove the filter from the bottom. The filter can be cleaned by shaking it or washing it in water. NB! The filter must be completely dry before being reinstalled. Replace the cleaned filter in the machine. Press the outer edge of the filter down against the sides of the container so that the filter bulges up slightly. Refit the dust bag and replace the lid. Check that the lid is sitting firmly in place. <b>Note: Never vacuum without a filter installed.</b>

**10.2 Service/maintenance - CVR 2000 / CVR 3000 / CVR 4000**



**NB! Never vacuum without a bag filter installed**

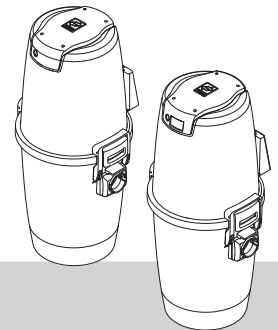

Product	How often?	Why?	How?
<b>Dust container</b>	Should be emptied before the container is 3/4 full, depending on use but normally 2-4 times a year.	Poor suction and danger of creating a blockage in the pipe system.	Release the two handles clamping the dust container. The handles are easily unlocked by lifting up the handles until they come to a stop. When you pull the handles outwards away from the cleaner, the container is released. Lift off the container. Lift out dust bag and. Empty the container in a plastic bag and put in dustbin. Any remaining dust or fluff can be removed manually.
<b>Dust bag</b>	Should be replaced before it becomes completely full, depending on use but normally 2-4 times a year.	Poor suction and danger of creating a blockage in the pipe system.	Release the two handles clamping the dust container. The handles are easily unlocked by lifting up the handles until they come to a stop. When you pull the handles outwards away from the cleaner, the container is released. Lift off the container. Lift out the filter. Then remove the dust bag by pulling the bag's cardboard stiffener off the nozzle. Replace in reverse order.
<b>Filter</b>	Should be shaken when the container is emptied.  NB: Only use dry cleaning methods	To maintain good suction power.	Release the two handles clamping the dust container. The handles are easily unlocked by lifting up the handles until they come to a stop. When you pull the handles outwards away from the cleaner, the container is released. Lift off the container. Do not remove the filter from the container. Instead, give the filter a light shaking inside the container to loosen dust from the filter and allow it to fall into the container. Lift out the bag filter. If a dust bag is being used - remove it. Then empty the dust from the container in a plastic bag and put in dustbin.



# 11 Dimensional drawings CVR 1000, CVR 2000, CVR 3000, CVR 4000

## CVR 1000

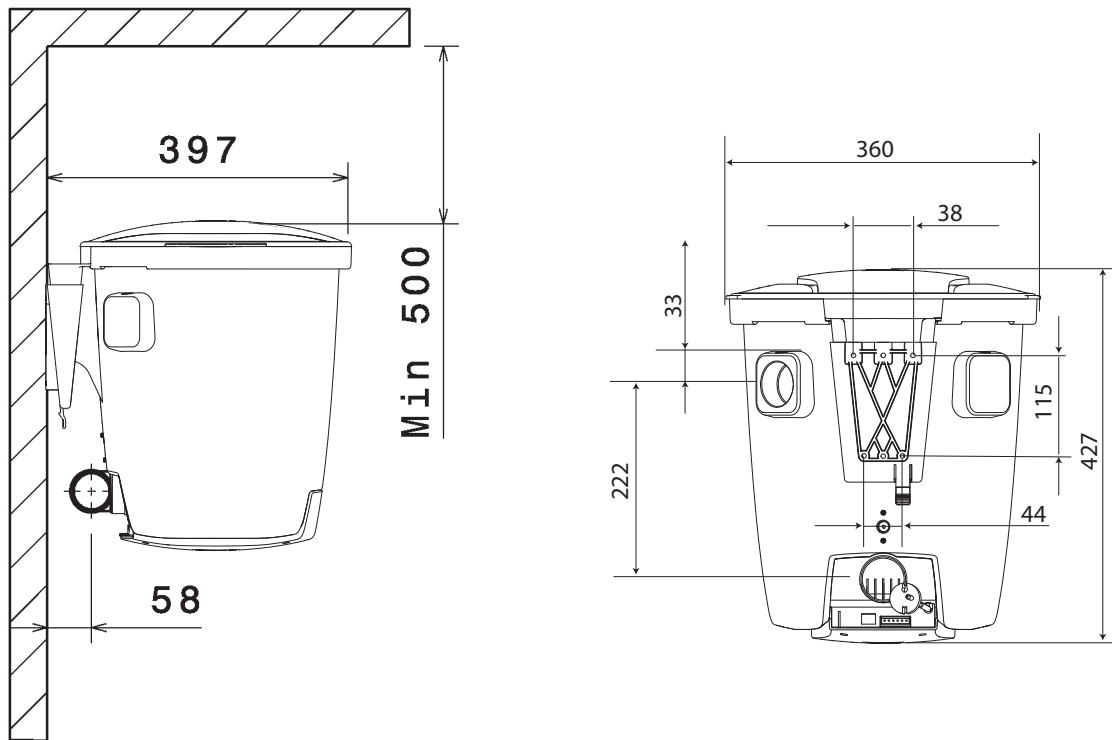



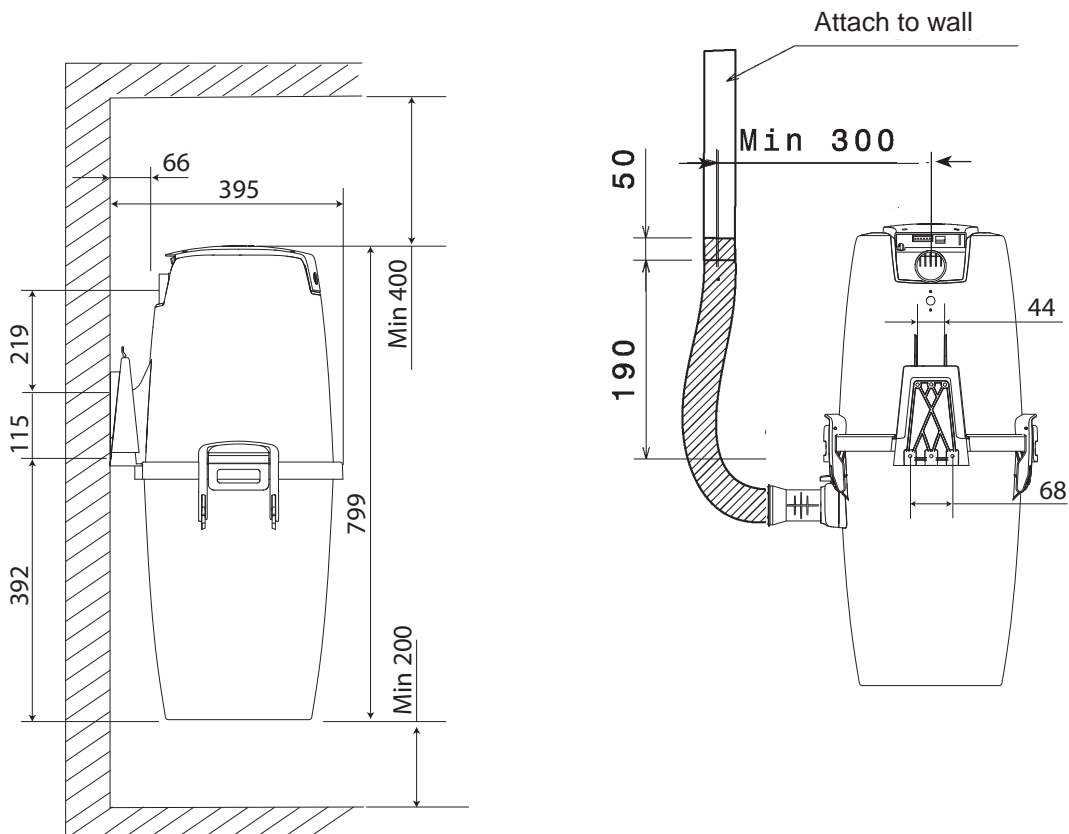



## CVR 2000 / CVR 3000 / CVR 4000

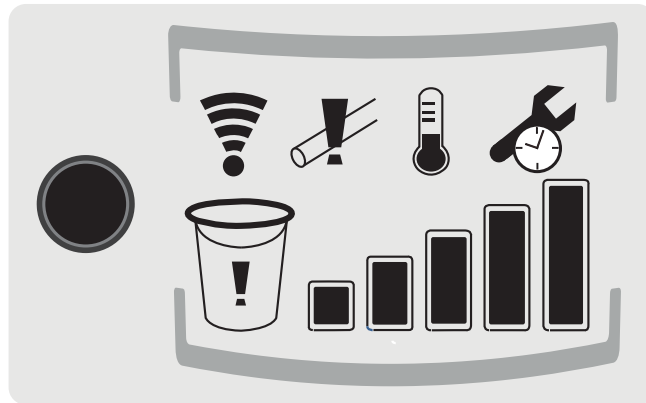

## 12 Symbol explanation







### Explanation of indication lights at the display for CVR 4000



	Speed level 	Service 	Air flow 	Bag/filter* 	Signal 	Overheating 
Signal lit	Bars show the actual speed level					
Signal flashing		Indicates for service warning. See 10 Troubleshooting	Indicates for blocked airflow. See 10 Troubleshooting	Dust bag or filter is clogged. Change dust bag and clean filter.	Hose handle is out of range. No connection to the cleaner.	Thermal cut-out has tripped and the cleaner has stopped. See 10 Troubleshooting

### Explanation of the indication lights at the LCD handle



	Speed level 	Battery 	Service 	Bag/filter* 	Signal 	Overheating 
Signal lit	Bars show the actual speed level					
Signal flashing		Battery is under 5%. Change battery	Indicates for service warning. See 10 Troubleshooting	Dust bag or filter is clogged. Change dust bag and clean filter.	Hose handle is out of range. No connection to the cleaner.	Thermal cut-out has tripped and the cleaner has stopped. See 10 Troubleshooting

\*As an extra precaution, the dust bag/filter symbol will also come on permanently after every 20 hours of operation. When this happens, check the bag filter and dust bag/container.

The warning can be reset when the machine is off by holding the machine's on/off button (not the handle) in for approx. 3 seconds until the machine stops.

## 13 CE Declaration of Conformity

<b>Product:</b>	Central vacuum cleaner
<b>Type:</b>	CVR 1000, CVR 2000, CVR 3000, CVR 4000
<b>Art.no.:</b>	04010, 04020, 04030, 04040
<b>Manufacturer:</b>	Nilfisk A/S Kornmarksvej 1 DK-2605 Brøndby
<b>The design of the unit corresponds to the following pertinent regulations:</b>	EC Low-voltage Directive 2006/95/EC EC EMC Directive 2004/108/EC RoHS Directive 2011/65/EC
<b>Applied harmonised standards:</b>	EN 55014-1: 2006 + A1: 2009 § A2: 2011 EN 61000-3-2: 2006 + A1: 2009 § A2: 2009 EN 61000-3-3: 2008 EN 55014-2: 1997 + A1: 2001 § A2: 2008 EN 301 489-1 V1.9.2 (2011-09) EN 301 489-3 V1.4.1 (2002-08) EN 3000220-2 V2.3.1 (2010-02) EN 3000220-1 V2.3.1 (2010-02) FCC Part 15C (2011) RSS-Gen (issue 3) (December 2010) RSS-210 (issue 8) (December 2010) IEC/EN 60335-1 5th ed. (2012) IEC/EN 60335-2-69 5th ed. (2012) IEC 60335-1 fifth ed. (2001)+A1+A2 IEC 60335-2-2 (2002)+A1+A2 IEC 60335-2-2: 2009 IEC 60335-1:2001+ A1:2004 + A2:2006 EN 60335-2-2:2010+A11 EN 60335-1:2002 +A11+A1+A12+A2+A13 +A14+A15 EN 62233:2008
<b>Applied national standards and technical specifications:</b>	IEC 60335-2-2 IEC 60335-2-69
	 Frank Petersen CEO  Flexit AS Televeien 15, N-1870 Ørje
<b>Place and date of the declaration</b>	Ørje, 01.12.2015



Flexit AS, Televeien 15, N-1870 Ørje [www.flexit.no](http://www.flexit.no)